

***TM 9-2320-303-10**

OPERATOR'S MANUAL

FOR

**TRUCK, TRACTOR, LINE HAUL:
52,000 GVWR, 6 X 4, M915A4
(NSN 2320-01-458-1207) (EIC: B4M)**

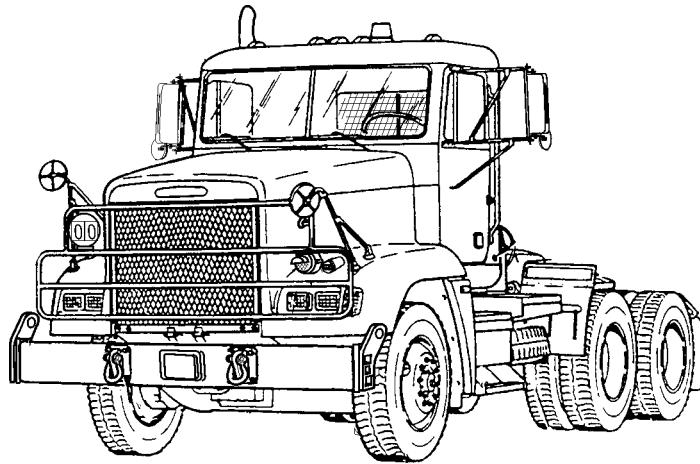

Approved for public release; distribution is unlimited.

HEADQUARTERS, DEPARTMENT OF THE ARMY

DECEMBER 2005

WARNING SUMMARY

This warning summary contains general safety warnings and hazardous materials warnings that must be understood and applied during operation and maintenance of this equipment. Failure to observe these precautions could result in serious injury or death to personnel. Also included are explanations of safety and hazardous materials icons used within the technical manual.



BIOLOGICAL - abstract symbol bug shows that a material may contain bacteria or viruses that present a danger to life or health.



CHEMICAL - drops of liquid on hand shows that the material will cause burns or irritation to human skin or tissue.



EAR PROTECTION - headphones over ears shows that noise level will harm ears.



ELECTRICAL - electrical wire to arm with electricity symbol running through human body shows that shock hazard is present.



EYE PROTECTION - person with goggles shows that the material will injure the eyes.



FIRE - flame shows that a material may ignite and cause burns.

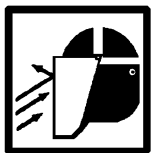

FLYING PARTICLES - arrows bouncing off face with face shield shows that particles flying through the air will harm face.

TM 9-2320-303-10



HEAVY OBJECT - human figure stooping over heavy object shows physical injury potential from improper lifting technique.



HEAVY PARTS - hand with heavy object on top shows that heavy parts can crush and harm.



HEAVY PARTS - heavy object on human figure shows that heavy parts present a danger to life or limb.



HOT AREA - hand over object radiating heat shows that part is hot and can burn.



VAPOR - human figure in a cloud shows that material vapors present a danger to life or health.

FOR INFORMATION ON FIRST AID, REFER TO FM 4-21.11.



WARNING

CARBON MONOXIDE (EXHAUST GASES) CAN KILL!

- Carbon monoxide is a colorless, odorless, deadly poison which, when breathed, deprives the body of oxygen and causes suffocation. Exposure to air containing carbon monoxide produces symptoms of headache, dizziness, loss of muscular control, apparent drowsiness, and coma. Permanent brain damage or death can result from severe exposure.
 - Carbon monoxide occurs in exhaust fumes of internal combustion engines. Carbon monoxide can become dangerously concentrated under conditions of inadequate ventilation. The following precautions must be observed to ensure safety of personnel when engine of truck is operated.
1. DO NOT operate vehicle in an enclosed area unless exhaust is vented to outside atmosphere.
 2. DO NOT drive truck with inspection plates or cover plates removed.
 3. BE ALERT for exhaust poisoning symptoms. They are:
 - Headache
 - Dizziness
 - Sleepiness
 - Loss of muscular control
 4. If you see another person with exhaust poisoning symptoms:
 - Remove person from area.
 - Expose to fresh air.
 - Keep person warm.
 - Do not permit physical exercise.
 - Administer cardiopulmonary resuscitation (CPR), if necessary.
 - Notify a medic.
 5. BE AWARE. The field protective mask for nuclear-biological-chemical (NBC) protection will not protect you from carbon monoxide poisoning.

The Best Defense Against Carbon Monoxide Poisoning Is Good Ventilation!



WARNING

BATTERIES



- To avoid eye injury, eye protection is required when working around batteries. DO NOT smoke, use open flame, make sparks or create other ignition sources around batteries. If a battery is giving off gases, it can explode and cause injury to personnel. Remove all jewelry such as rings, ID tags, watches, and bracelets. If jewelry or a tool contacts a battery terminal, a direct short will result in instant heating, injury to personnel, and damage to equipment.
- Sulfuric acid contained in batteries can cause serious burns. Always wear goggles, gloves, and apron. If battery corrosion or electrolyte makes contact with skin, eyes, or clothing, take immediate action to stop the corrosive burning effects. Failure to follow these procedures may result in death or serious injury to personnel.
 - a. **Eyes.** Flush with cold water for no less than 15 minutes and seek medical attention immediately.
 - b. **Skin.** Flush with large amounts of cold water until all acid is removed. Seek medical attention as required.
 - c. **Internal.** If corrosion or electrolyte is ingested, drink large amounts of water or milk. Follow with milk of magnesia, beaten egg, or vegetable oil. Seek medical attention immediately.
 - d. **Clothing/Equipment.** Wash area with large amounts of cold water. Neutralize acid with baking soda or household ammonia.

WARNING

BRAKES

- DO NOT use trailer handbrake to prevent trailer from jackknifing because this may cause trailer to jackknife. Modern airbrake systems are designed to deliver the right amount of air to all wheels to stop vehicle without jackknifing. Failure to follow this warning may result in death or injury to personnel or damage to equipment.
- DO NOT use trailer handbrake as primary brake to keep tension on coupling system. This will cause undue tension on brakes and coupling which could result in injury to personnel or damage to equipment. Prevent problems with slack in fifth wheel by using good braking habits and adjusting coupling and braking systems properly.
- When caging brakes, block wheels to keep truck from moving when brakes are released. Failure to follow this warning may result in death or injury to personnel or damage to equipment.
- DO NOT use engine brake if road surfaces are slippery. Use of engine brake on wet, icy, or snow-covered roads could result in loss of vehicle control. Failure to follow this warning could result in death or injury to personnel or damage to equipment.
- Brake chamber contains spring under great pressure. To prevent personnel injury, never work directly behind chamber. If caging bolt will not engage properly, spring may be broken.
- DO NOT remove clamp ring around spring brake chamber. It is under tension and can cause personnel injury if released.
- When spring brakes are applied, vehicle will stop quickly which could result in injury to personnel. Also, vehicle cannot be driven again until malfunction is repaired and enough air supply is present for operation of service brakes.

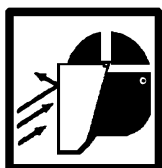

WARNING

COMPRESSED AIR

Compressed air used for cleaning or drying purposes, or for clearing restrictions, should never exceed 30 psi (207 kPa). Wear protective clothing (goggles/shield, gloves, etc.) and use caution to avoid injury to personnel.



WARNING

DIESEL FUEL HANDLING

- DO NOT smoke or permit any open flame in area of truck while you are servicing diesel fuel system. Be sure hose nozzle is grounded against filler tube during refueling to prevent static electricity. Failure to follow this warning may result in injury to personnel or equipment damage.
- Auxiliary heater, if equipped, must be switched to OFF while refueling. Fuel may ignite, causing injury or death to personnel and damage to vehicle.
- DO NOT perform fuel system checks, inspections or maintenance while smoking or near fire, flames or sparks. Fuel may ignite, causing injury or death to personnel and damage to vehicle.
- Personnel must wear fuel-resistant gloves when handling fuels. If exposed to fuel, promptly wash exposed skin and change fuel-soaked clothing.



WARNING

ETHER QUICK-START SYSTEM

Ether is highly flammable and explosive. DO NOT perform ether quick-start system checks or inspections while smoking or near fire, flame or sparks. Failure to follow this warning may cause a fire and explosion, causing serious injury or death to personnel.



WARNING

FIRE EXTINGUISHER

Discharging large quantities of dry chemical fire extinguisher in cab may result in temporary breathing difficulty during and immediately after the discharge event. If at all possible, discharge fire extinguisher from outside the cab. Avoid unnecessary contact during use and cleanup. Contact local medical personnel to determine necessary personal protective equipment to wear during cleanup.



WARNING

HEARING PROTECTION

Hearing protection is required when operating vehicle at more than 40 mph (64 kph) with windows open for an extended period of time. Hearing protection is also required when personnel are within 5.2 ft (1.57 m) of vehicle when operating at low engine idle (600 rpm) and within 16.5 ft (5 m) of vehicle when operating at high idle (1600 rpm). Failure to follow this warning may result in hearing damage.



WARNING

NBC EXPOSURE

If NBC exposure is suspected, all air cleaner media should be handled by personnel wearing protective equipment. Consult your NBC Officer or NBC NCO for appropriate handling or disposal procedures.

 WARNING
IF NBC EXPOSURE IS SUSPECTED ALL AIR FILTER MEDIA WILL BE HANDLED BY PERSONNEL WEARING FULL NBC PROTECTIVE EQUIPMENT. SEE OPERATOR/MAINTENANCE MANUAL. 7690-01-114-3702

To order this NBC decal use:

National Stock Number (NSN) - 7690-01-114-3702

Part Number (PN) - 12296626

Commercial and Government Entity Code (CAGEC) - 19207



WARNING

SINCGARS RADIO

DO NOT make contact with any bare metal/wire surface of active SINCGARS antenna elements. Failure to follow this warning could result in radio frequency (RF) shock or burn.



WARNING

SLAVE STARTING

- When slave starting truck, use NATO slave cable that DOES NOT have loose or missing insulation.
- DO NOT proceed if suitable cable is not available.
- DO NOT use civilian-type jumper cables.
- Failure to follow this warning could result in injury.

WARNING

TIRE CHANGING

Whenever wheel lug nuts require tightening or a wheel has been removed and replaced, lug nuts must be tightened to the required torque. Failure to follow this warning may result in serious injury to personnel and damage to equipment.

WARNING

TOWING

Brakes will be released when air is applied to a disabled vehicle. DO NOT connect air lines to a disabled vehicle without first blocking wheels and connecting tow bar between vehicles. Failure to follow this warning could result in death or injury to personnel and damage to equipment.

WARNING

TRUCK OPERATION

- BE ALERT for personnel in area while operating truck. Always check to ensure area is clear of personnel and obstructions before moving out. Failure to follow this warning may result in serious injury or death to personnel.
- Use of seat belts while operating vehicle is mandatory. Fasten belt BEFORE driving. Trying to fasten three-point belt while driving creates a hazardous condition. Failure to follow this warning may result in death or injury to personnel.
- Serious injury may result if head clearance is not adequate while sitting in seat. Before driving or riding in vehicle, ensure there is adequate clearance at maximum upward travel of seat.
- Ensure that steering wheel adjustment control lever is in locked (neutral) position before driving truck. NEVER try to adjust tilt or height of steering wheel while driving. Failure to follow this warning may cause death or injury to personnel.
- Use caution when coupling to or uncoupling from semitrailer. BE ALERT for personnel in area. Ensure that hands, arms, and body are clear of potential pinch points. Failure to follow this warning may result in injury to personnel.
- Operating truck with an underinflated or defective tire may lead to tire failure and loss of steering control. Injury to personnel or damage to equipment may result.
- This vehicle has been designed to operate safely and efficiently within the limits specified in this TM. Operation beyond these limits is prohibited in accordance with AR 70-1 without written approval from: Commander, U.S. Army Tank-automotive and Armaments Command, ATTN: AMSTA-DSA-FP-IM, Warren, MI 48397-5000.
- If vehicle is left with engine running, vehicle can move suddenly causing serious injury or death to personnel or damage to equipment.

WARNING

WHOLE-BODY VIBRATION

When coupled to a semitrailer, DO NOT exceed 35 mph (56 kph) on secondary (gravel) roads. Failure to follow this warning could result in injury.

WARNING

WORK SAFETY



- Use caution when lifting or handling wheel and tire assembly. It is heavy and could cause injury if improperly lifted or if it falls on you.



- Hydraulic jack is intended only for lifting truck, not for supporting vehicle to perform maintenance. DO NOT get under truck after it is raised unless it is properly supported with blocks or jackstands. Failure to observe this warning may result in death or injury to personnel.

- Ensure air flow valve lever is in full horizontal position. Failure to follow this warning could result in loss of trailer or truck brakes.



- Lifting cables, chains, hooks, and slings used for lifting truck must be in good condition and of suitable capacity. Failure to follow this warning may result in injury or death to personnel and damage to equipment.



- Improper use of lifting equipment and improper attachment of cables to vehicle can result in serious injury to personnel and equipment damage. Observe all standard rules of safety.



- ALWAYS install hood prop after opening hood. Failure to follow this warning could result in severe injury to personnel.

TM 9-2320-303-10

LIST OF EFFECTIVE PAGES/WORK PACKAGES

Dates of issue for original and change pages/work packages are:

Original December 2005

TOTAL NUMBER OF PAGES FOR FRONT AND REAR MATTER IS 24 AND TOTAL NUMBER OF WORK PACKAGES IS 21 CONSISTING OF THE FOLLOWING:

Page/WP No.	*Change No.
Cover (Back Blank)	0
a to j	0
A/(B Blank)	0
i and iv	0
iii thru v/(vi Blank)	0
WP 0001 00 thru WP 0021 00	0
Index -1 to Index-5/(Index-6 Blank)	0
Authentication Page (Back Blank)	0
Sample DA Form 2028-2	0
Blank DA Form 2028-2	0
Metric Conversion Chart	0
Back Cover	0

* Zero in this column indicates an original page or work package.

A/B blank

TM 9-2320-303-10

*TECHNICAL MANUAL
TM 9-2320-303-10

HEADQUARTERS
DEPARTMENT OF THE ARMY
Washington, D.C., 31 December 2005

OPERATOR'S MANUAL

FOR

**TRUCK, TRACTOR, LINE HAUL:
52,000 GVWR, 6 X 4, M915A4
(NSN 2320-01-458-1207) (EIC:B4M)**

REPORTING ERRORS AND RECOMMENDING IMPROVEMENTS

You can help improve this publication. If you find any mistakes or if you know of a way to improve the procedures, please let us know. Submit your DA Form 2028 (*Recommended Changes to Equipment Technical Publications*), through the Internet, on the Army Electronic Product Support (AEPS) website. The Internet address is <https://aeaps.ria.army.mil/>. The DA Form 2028 is located under the Public Applications section in the AEPS Public Home Page. Fill out the form and click on SUBMIT. Using this form on the AEPS will enable us to respond quicker to your comments and better manage the DA Form 2028 program. You may also mail, fax or e-mail your letter or DA Form 2028 direct to: AMSTA-LC-LPIT/TECH PUBS, TACOM-RI, 1 Rock Island Arsenal, Rock Island, IL 61299-7630. The e-mail address is: TACOM-TECH-PUBS@ria.army.mil. The fax number is DSN 793-0726 or Commercial (309) 782-0726.

TABLE OF CONTENTS

	Page
Warning Summary	a
How To Use This Manual	iii
 CHAPTER 1 GENERAL INFORMATION, EQUIPMENT DESCRIPTION, AND THEORY OF OPERATION	
WP 0001 00 General Information0001 00-1
WP 0002 00 Equipment Description and Data0002 00-1
WP 0003 00 Theory of Operation0003 00-1
 CHAPTER 2 OPERATOR INSTRUCTIONS	
WP 0004 00 Description and Use of Operator's Controls and Indicators0004 00-1
WP 0005 00 Operation Under Usual Conditions0005 00-1
WP 0006 00 Operation Under Unusual Conditions0006 00-1
WP 0007 00 Stowage and Decal, Data Plate, and Stencil Guide0007 00-1

TABLE OF CONTENTS - CONTINUED

	Page
CHAPTER 3 OPERATOR TROUBLESHOOTING	
WP 0008 00 Troubleshooting Instructions0008 00-1
WP 0009 00 Troubleshooting Symptom Index0009 00-1
WP 0010 00 Troubleshooting Procedures0010 00-1
CHAPTER 4 OPERATOR MAINTENANCE INSTRUCTIONS	
WP 0011 00 Preventive Maintenance Checks and Services (PMCS) Introduction0011 00-1
WP 0012 00 Preventive Maintenance Checks and Services (PMCS)0012 00-1
WP 0013 00 Truck Cleaning and Refueling Instructions0013 00-1
WP 0014 00 Wheel and Tire Maintenance Instructions0014 00-1
WP 0015 00 Battery Box Cover Replacement0015 00-1
WP 0016 00 Rear Window Guard Replacement0016 00-1
WP 0017 00 Lubrication Instructions0017 00-1
CHAPTER 5 SUPPORTING INFORMATION	
WP 0018 00 References0018 00-1
WP 0019 00 Components of End Item (COEI) and Basic Issue Items (BII) Lists0019 00-1
WP 0020 00 Additional Authorization List (AAL)0020 00-1
WP 0021 00 Expendable and Durable Items List0021 00-1
Index	Index-1

HOW TO USE THIS MANUAL

INTRODUCTION

1. This manual is designed to help you operate the M915A4 and perform operator troubleshooting and maintenance on the equipment.
2. This manual is written in Work Package format:
 - a. Chapters divide the manual into major categories of information (e.g., *Introductory Information with Theory of Operation, Operating Instructions, Operator Troubleshooting, Operator Maintenance Instructions, and Supporting Information*).
 - b. Each Chapter is divided into Work Packages, which are identified by a 6-digit number (e.g. 0001 00, 0002 00, etc.) located on the upper right-hand corner of each page. The Work Package page number (e.g. 0001 00-1, 0001 00-2, etc.) is located centered at the bottom of each page.
 - c. If a Change Package is issued to this manual, added Work Packages use the 5th and 6th digits of their number to indicate new material. For instance, Work Packages inserted between WP 0001 00 and WP 0002 00 are numbered WP 0001 01, WP 0001 02, etc.
3. Scan thru this manual to become familiar with its organization and contents before attempting to operate or maintain the equipment.

CONTENTS OF THIS MANUAL

1. A *Warning Summary* is located at the beginning of this manual. Become familiar with these warnings before operating or performing operator troubleshooting or maintenance on the vehicle.
2. A *Table of Contents*, located in the front of the manual, lists all Chapters and Work Packages in the publication.
 - a. The Table of Contents also provides *Reporting Errors and Recommending Improvements* information and DA Form 2028 addresses, for the submittal of corrections to this manual.
 - b. If you cannot find what you are looking for in the Table of Contents, refer to the alphabetical *Index* at the back of the manual.
3. Chapter 1, *General Information, Equipment Description, and Theory of Operation*, provides general information on the manual and the equipment.
4. Chapter 2, *Operator Instructions*, explains and illustrates all operator controls and indicators, and describes how to perform all operating procedures for the M915A4: *Operation Under Usual Conditions and Operation Under Unusual Conditions*.
5. Chapter 3 covers all *Operator Troubleshooting*. WP 0009 00 is a *Troubleshooting Symptom Index*. If the vehicle malfunctions, this index should always be consulted to locate the appropriate troubleshooting procedure.
6. Chapter 4 covers all *Operator Maintenance Instructions*: Major areas covered are *Preventive Maintenance Checks and Services (PMCS)* and operator level maintenance tasks.
7. Chapter 5 covers *Supporting Information: References, Components of End Item (COEI) and Basic Issue Items (BII) Lists, Additional Authorization List (AAL), and Expendable and Durable Items List*.

FEATURES OF THIS MANUAL

1. WARNINGS, CAUTIONS, NOTES, subject headings, and other important information are highlighted in **BOLD** print as a visual aid.

WARNING

A WARNING indicates a hazard which may result in death or serious injury.

CAUTION

A CAUTION is a reminder of safety practices or directs attention to usage practices that may result in damage to equipment.

NOTE

A NOTE is a statement containing information that will make the procedures easier to perform.

2. Statements and words of particular interest may be printed in CAPITAL LETTERS to create emphasis.
3. Within a procedural step, reference may be made to another Work Package in this manual or to another manual. These references indicate where you should look for more complete information.
 - a. If you are told: "Perform *After* Operation PMCS (WP 0012 00)", go to Work Package 0012 00 in this manual for *After* Operation PMCS.
 - b. If you are told: "Refer to FM 21-305 for General Guidelines on vehicle recovery", go to FM 21-305, which is listed in the *References* Work Package, for complete information on vehicle recovery.
4. Illustrations are placed after, and as close to, the procedural steps to which they apply. Callouts placed on the art may be text or numbers, or both; whichever method is easier for the soldier.
5. Numbers located at lower right corner of art (e.g. 402-001, 402-002, etc.) are art control numbers and are used for tracking purposes. Disregard these numbers.
6. Dashed leader lines used in illustrations indicate that called out items are not visible in the view depicted (i.e. they are located within the structure).
7. Technical instructions include metric units as well as standard units. For your reference, a *Metric Conversion Chart* is located on the inside back cover of the manual.

NOTE

If at any time you are unsure how to use this manual or you cannot locate the information you need, notify your supervisor.

TM 9-2320-303-10

CHAPTER 1
GENERAL INFORMATION, EQUIPMENT DESCRIPTION,
AND THEORY OF OPERATION

GENERAL INFORMATION

0001 00

SCOPE

1. **Type of Manual.** This manual is for use in operating and maintaining the M915A4 truck tractor.
2. **Equipment Name and Model Number.** Truck, Tractor, Line Haul: 52,000 GVWR, 6X4, M915A4.
3. **Purpose of Equipment.** The M915A4 truck tractor is a 6 X 4 prime mover of semitrailers used primarily to transport containers, bulk cargo, and petroleum products over primary and secondary roads under worldwide climatic conditions in a military environment.

MAINTENANCE FORMS AND PROCEDURES

Department of the Army forms and procedures used for the equipment will be those prescribed by DA Pam 738-750, *Functional User's Manual for the Army Maintenance Management System (TAMMS)*, as contained in the Maintenance Management Update.

REPORTING EQUIPMENT IMPROVEMENT RECOMMENDATIONS (EIRS)

If your truck needs improvement, let us know. Send us an EIR. You, the user, are the only one who can tell us what you don't like about your equipment. Let us know why you don't like the design or performance. Put it on an SF Form 368 (*Product Quality Deficiency Report*). Mail it to us at: Commander, U.S. Army Tank-automotive and Armaments Command, ATTN: AMSTA-LC-LMIT, Rock Island, Illinois 61299-7630. We'll send you a reply.

CORROSION PREVENTION AND CONTROL (CPC)

1. Corrosion Prevention and Control (CPC) of Army materiel is a continuing concern. It is important that any corrosion problems with this item be reported so that the problem can be corrected and improvements can be made to prevent the problem in future items.
2. While corrosion is typically associated with rusting of metals, it can also include deterioration of other materials, such as rubber and plastic. Unusual cracking, softening, swelling, or breaking of these materials may be a corrosion problem.
3. If a corrosion problem is identified, it can be reported using SF Form 368 (*Product Quality Deficiency Report*). Use of key words such as "corrosion," "rust," "deterioration," or "cracking" will ensure that the information is identified as a CPC problem. The form should be submitted to the address specified in DA Pam 738-750.

GENERAL INFORMATION - CONTINUED

0001 00

OZONE DEPLETING SUBSTANCES (ODS)

Listing to be provided by requiring activity.

DESTRUCTION OF ARMY MATERIEL TO PREVENT ENEMY USE

For destruction of Army materiel to prevent enemy use, refer to TM 750-244-6.

PREPARATION FOR STORAGE OR SHIPMENT

Before loading M915A4/M967A2 tractor-trailer combination onto a Roll-on/Roll-off (RO/RO) ship, contact unit maintenance to remove fuel tank step assembly.

For additional preparation for storage or shipment procedures, refer to TM 9-2320-303-24.

WARRANTY INFORMATION

The vehicles are warranted by Freightliner Corporation in accordance with TB 9-2320-303-15. Warranty starts on the date found in block 23, DA Form 2408-9 in the logbook. Report all defects in material or workmanship to your supervisor, who will take appropriate action through your Unit Maintenance shop.

NOMENCLATURE CROSS-REFERENCE LIST

COMMON NAME	OFFICIAL NOMENCLATURE
Cold Start System	Ether Quick-Start System
Engine Coolant	Antifreeze, Ethylene Glycol Mixture
Gladhand	Quick Disconnect Coupling
Jake Brake	Engine Brake
Komfort Loc®	Seat Belt Adjustment
No Spin®	Automatic Locking Positive Traction Differential

LIST OF ABBREVIATIONS

NOTE

Refer to ASME Y14.38-1999 for standard abbreviations.

ABBREVIATION	DEFINITION
AAL	Additional Authorization List
ABS	Anti-Lock Brake System
BII	Basic Issue Items
C	Centigrade or Celsius
CID	Cubic Inch Displacement

GENERAL INFORMATION - CONTINUED

0001 00

LIST OF ABBREVIATIONS - CONTINUED

ABBREVIATION	DEFINITION
cm	Centimeter
COEI	Components of End Item
CWS	Collision Warning System
ECU	Electronic Control Unit
F	Fahrenheit
GCWR	Gross Combination Weight Rating
GVWR	Gross Vehicle Weight Rating
kg	Kilogram
km	Kilometer
kPa	Kilopascal
kph	Kilometers per Hour
kW	Kilowatt
l	Liter
lb	Pound
lb-ft	Pound foot
lph	Liters per Hour
m	Meter
mm	Millimeter
Nm	Newton meter
PMCS	Preventive Maintenance Checks and Services
psi	Pounds per Square Inch
rpm	Revolutions per Minute
TMDE	Test, Measurement, and Diagnostic Equipment

END OF WORK PACKAGE

EQUIPMENT CHARACTERISTICS, CAPABILITIES, AND FEATURES**1. Characteristics.**

- a. The M915A4 is used to transport M871, M872, M967/M969 5,000 gallon fuel tankers, and M1062 7,500 gallon fuel tankers on line haul missions.
- b. It has a Gross Vehicle Weight Rating (GVWR) of 52,000 lb (23,608 kg) and is equipped with a two-way oscillating, sliding fifth wheel compatible with a two-inch kingpin. Maximum towed load on kingpin is 30,000 lb (13,620 kg).

2. Capabilities and Features.

- a. While operating on Class I roads, the fully loaded M915A4 can maintain a speed of 55 mph (88 kph) on level roads and 29 mph (47 kph) while ascending a 3 percent grade. It has a minimum turning diameter, curb-to-curb, of 53 ft 9 in. (16.4 m).
- b. Average cruising ranges at Gross Combination Weight Rating (GCWR) with a full tank of fuel will vary based on conditions (e.g., varying loads, prolonged idle, and climatic conditions). Cruising range is optimally 300 miles (483 km).
- c. The M915A4 is equipped with an instrument panel mounted speedometer and tachometer which register truck ground speed and engine speed.
- d. The M915A4 has the following capabilities and features:
 - (1) air-activated front and rear non-asbestos cam brakes with a four-channel anti-lock brake system (ABS) to provide significantly improved handling and braking during emergency stops;
 - (2) operation in temperatures from -25°F (-32°C) to +125°F (+52°C), and to -40°F (-40°C) with arctic kit installed;
 - (3) start and climb capability of a 20 percent grade at GCWR in both forward and reverse directions;
 - (4) fording capability up to 20 in. (51 cm) deep for 5 minutes without damage or requiring maintenance before operations can continue;
 - (5) two-passenger aluminum corrosion-proof cab with a 90 degree tilt-forward hood for service accessibility;
 - (6) six cylinder, 14 liter, 400 horsepower, in-line turbocharged diesel engine built by Cummins;
 - (7) Allison HD 4560P four-speed (or five-speed if equipped) automatic transmission.
- e. When operating in arctic conditions, the M915A4 can be equipped with an arctic heater, mounted under the cab, above the battery box. This provides heat for the cab and the engine cooling system. The arctic heater may be operated prior to starting the engine to provide preheating of engine block.
- f. Collision Warning System (CWS) that warns the driver of potentially dangerous driving situations by activating visual and audible alerts.

LOCATION AND DESCRIPTION OF MAJOR COMPONENTS

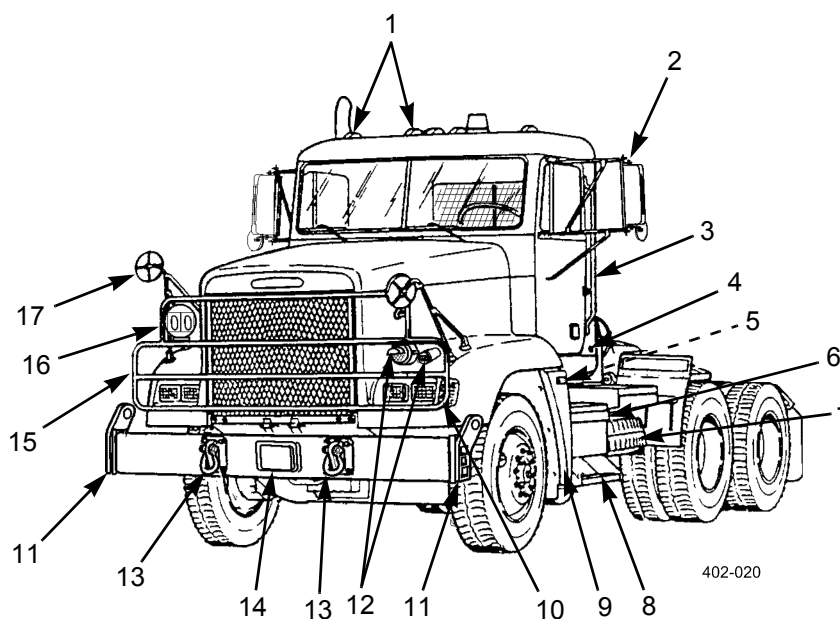

Key	Component	Description
1	Marker Clearance Lights	Indicate outline of truck.
2	Side Mirrors (Heated)	Provide driver with a view of sides of truck.
3	Grabhandles	Provide a hand hold for personnel climbing on truck.
4	Utility Power Receptacle	Supplies power for work lights. Located on both sides of truck.
5	Air Horn	Provides an audible alert.
6	Master Battery Switch	Provides battery power to truck.
7	Spare Wheel and Tire	Extra wheel and tire used in case of a flat tire.
8	Battery Box and Steps	Holds vehicle batteries and provides steps to access cab.
9	NATO Slave Receptacle	Provides connection point for NATO cable to slave start vehicle.
10	Front Service Lights	Include headlights and turn signals.
11	Bumper Extensions	Provide adjustable attachment point for slings.

EQUIPMENT DESCRIPTION AND DATA - CONTINUED

0002 00

LOCATION AND DESCRIPTION OF MAJOR COMPONENTS - CONTINUED

Key	Component	Description
12	Blackout Lights	Used during blackout conditions. Includes marker and drive lights.
13	Towing Eyes	Provide attachment points for towing device.
14	CWS Antenna	Forward looking collision warning system antenna.
15	Brush Guard	Protects front of hood and components under hood from damage.
16	Military Classification Sign	Placard used to display military weight classification.
17	Spotting Mirrors	Provide added visibility to sides of truck and semitrailer if towing.

LOCATION AND DESCRIPTION OF MAJOR COMPONENTS - CONTINUED

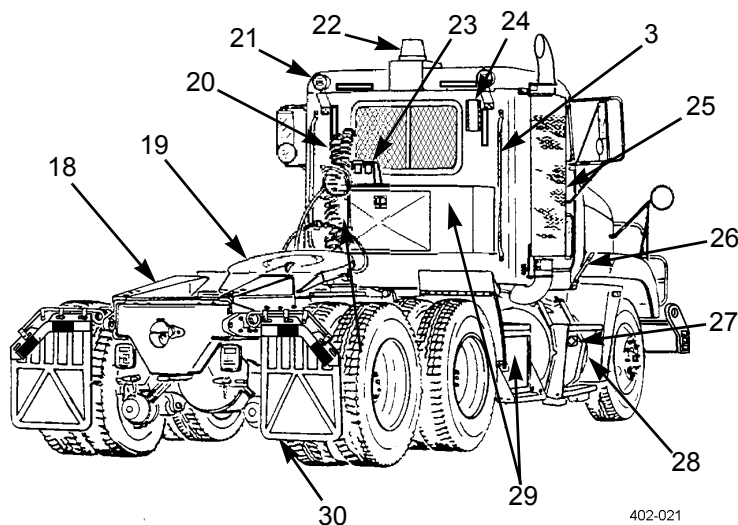

Key	Component	Description
3	Grabhandles	Provide a hand hold for personnel climbing on truck.
18	Ramp	Sloped surface serves as an approach to fifth wheel and facilitates coupling of semitrailer.
19	Fifth Wheel	Coupling device for semitrailers with kingpins.
20	Air Lines	Provide air supply for trailer brakes.
21	Utility Lights	Illuminate area in back of cab. There is one light on each side of cab.
22	Beacon Warning Light	Amber rotating light alerts other vehicles of presence of truck.
23	Intervehicular Receptacles	Contains 12-volt commercial, 24-volt military, and trailer ABS receptacles.
24	Antenna Mount	Mount for radio antenna.
25	Exhaust Muffler	Deadens noise of engine exhaust.
26	Hood Latch	Locks hood closed. Located on both sides of hood.
27	CWS Side Sensor	Side looking collision warning system sensor.
28	Fuel Tank	Holds fuel. Steps mounted to tank provide access to cab.
29	Storage Boxes	Provide stowage area for BII and other items.
30	Mud Flaps	Prevent water and debris from spraying up on passers by or towed semitrailer.

LOCATION AND DESCRIPTION OF MAJOR COMPONENTS - CONTINUED

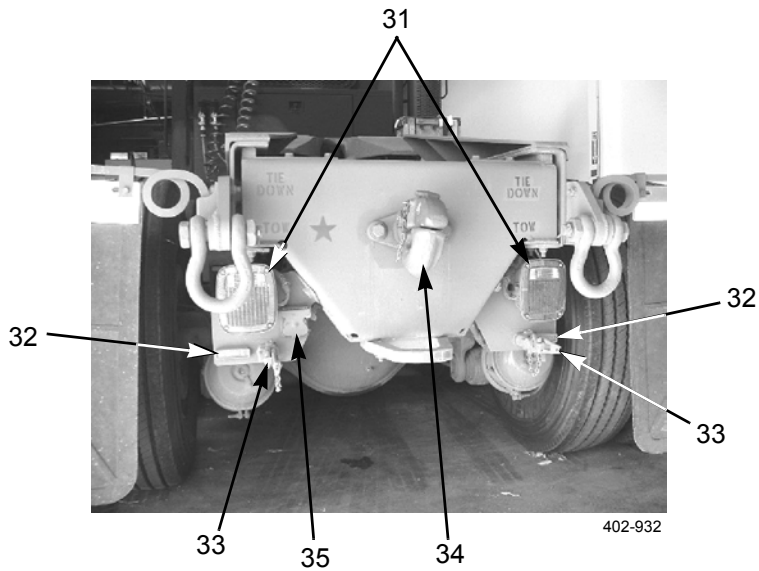

Key	Component	Description
31	Taillights	Contain composite tail, stop, backup, and turn signal lights.
32	Blackout Lights	Used during blackout conditions. Includes marker and stop lights.
33	Trailer Gladhands	Provide air supply for brakes of trailer.
34	Pintle Hook	Coupling device for trailers with lunettes.
35	Power Receptacle	24V electrical receptacle used for lunette towing.

EQUIPMENT DESCRIPTION AND DATA - CONTINUED

0002 00

EQUIPMENT DATA

Dimensions:

Length (Overall)	275.5 in. (700 cm)
Height (Overall).....	119 in. (302 cm)
Width (Overall).....	98 in. (249 cm)
Wheelbase	162 in. (411 cm)
Ground Clearance	9 in. (23 cm)
Angle of Approach	27°

Weights:

Curb	18,680 lb (8481 kg)
GVWR.....	52,000 lb (23,608 kg)
GCWR.....	105,000 lb (46,670 kg)
Front Axle (Loaded)	12,000 lb (5448 kg)
Rear Axle (Loaded)	40,000 lb (18,160 kg)

Capacities:

Engine Oil (Refill w/Filters)	46 qt (43.5 l)
Cooling System	17.25 gal. (65.3 l)
Fuel Tank.....	100 gal. (378.5 l)
Power Steering Reservoir	2 qt (1.9 l)
Transmission	51 qt (48 l)
Rear Axle (Forward/Rear).....	40/36 pts (19/17 l)

Engine:

Manufacturer	Cummins
Type.....	4-stroke, in-line turbocharged diesel
Model.....	NTC-400
Cylinders	6
Displacement	855 CID (14 l)
Torque @ 1500 rpm.	1150 lb.-ft. (1559 Nm)
Maximum Horsepower @ 2100 rpm.....	400 (298.3 kW)
Maximum Governed Speed	2100 rpm
Oil Filter Type.....	1 bypass, 1 primary, replaceable elements
Oil Filter Quantity	2

EQUIPMENT DESCRIPTION AND DATA - CONTINUED

0002 00

EQUIPMENT DATA - CONTINUED

Fuel System:

Type diesel fuel injected
 Fuel Tank:
 Type cylinder
 Quantity 1
 Air Cleaner:
 Type dry element
 Quantity 1

Cooling System:

Radiator Working Pressure 10 psi (69 kPa)

Electrical System:

Type dual 12/24 volt
 Batteries:
 Quantity 4
 Voltage 12 volt

Transmission:

Manufacturer Allison
 Model HD 4560P
 Type 4-speed (or 5-speed,
 if equipped) automatic
 Shift Selector pushbutton

Front Axle:

Manufacturer Rockwell
 Type I-beam, FF961
 Rated Capacity 12,000 lb (5448 kg)
 Maximum Steering Angle 32°

Rear Axle (Tandem):

Manufacturer Rockwell, SQHP
 Rated Capacity 38,000 lb (17,252 kg)
 Ratio 4.44:1
 Interaxle Differential bevel gear
 Interaxle Differential Lockup air control

EQUIPMENT DESCRIPTION AND DATA - CONTINUED

0002 00

EQUIPMENT DATA - CONTINUED

Brake System:

Actuation	air-mechanical
Pressure Range	60-120 psi (414-827 kPa)
Airbrake Chambers:	
Service	2 on front axle
Failsafe (Spring)	4 on forward-rear and rear-rear axles
ABS (Anti-Lock Brake System):	
Type	4-channel
Location	front axle and rear-rear axle

Wheels:

Size	22.5 x 8.25 in.
Number of Studs/Stud Size	10/1.125 in.

Tires:

Type	tubeless, radial on-highway
Size	11R22.5
Ply Rating	14PR
Load Range	H
Inflation Pressure (Maximum Load):	
Front	105 psi (724 kPa)
Rear	100 psi (690 kPa)
Spare	105 psi (724 kPa)

Steering:

Manufacturer	Ross
Steering Gear Type	single gear
Actuation	hydraulic power booster
Power Steering Pump	Eaton B165R
Turning Diameter	53 ft 9 in. (16.4 m)
Steering Column and Wheel:	
Type	tilt, telescoping
Tilt Range	15°
Telescoping Range	2 5/8 in. (67 mm)

Towing Attachments:

Pintle Hook:	
Manufacturer	Holland
Model	no. 760
Rated Capacity	30 tons (27.2 metric tons)

EQUIPMENT DESCRIPTION AND DATA - CONTINUED

0002 00

EQUIPMENT DATA - CONTINUED

Towing Eyes:

Quantity	2 front, 2 rear
Maximum Load Capacity, Each..... (Up to 45 ° Angle Front Long. Axis)	60,000 lb (27,240 kg)

Fifth Wheel:

Manufacturer	Holland
Type	36 in. (91.4 cm) diameter, 2-way oscillating, low lube
Capacity	30,000 lb (13,620 kg)
Height (Empty).....	51 in. (129.5 cm)
Pitch (Fwd/Aft).....	15/10°
Kingpin Size.....	2 in. (5.1 cm)

Cab:

Manufacturer	Freightliner
Construction.....	aluminum
Type.....	2-passenger, tilt-forward hood

Accessories:

Utility Lights	2 fixed, top rear of cab
Air Horn.....	1, under cab

Military Load Classification:

Vehicle w/o Trailer	8
Vehicle w/Trailer:	
M871	14/35 (unloaded/loaded)
M872	14/46 (unloaded/loaded)
M1062	11/34 (unloaded/loaded)
M967	13/29 unloaded/loaded)
M969	14/30 (unloaded/loaded)

END OF WORK PACKAGE

INTRODUCTION

1. The M915A4 vehicles consist of twelve functional systems: drive train, fuel system, exhaust system, cooling system, electrical system, air system, brakes, steering, air conditioning, collision warning system, traction control system, and suspension system.
2. This section explains the overall operation of these systems.

DRIVE TRAIN

The drive train of the M915A4 consists of a Cummins NTC-400 engine and an Allison 4-speed (or 5-speed, if equipped) automatic transmission connected to Rockwell SQHP rear tandem axles.

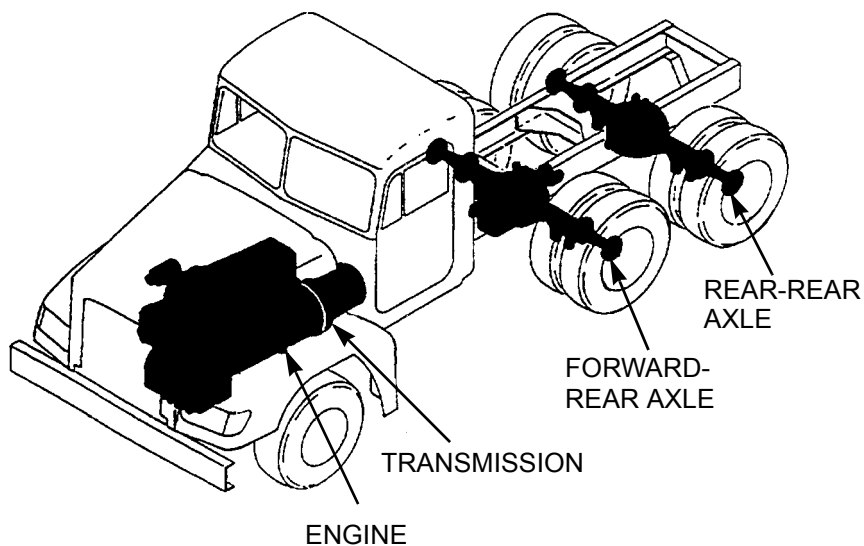

402-022

FUEL SYSTEM

1. Fuel to power the engine is pumped out of the fuel tank by an engine-mounted fuel injector pump.
2. The engine fuel system consists of one fuel injector pump, one injector per cylinder, fuel lines, a primary fuel filter, and a fuel filter/water separator.
3. The engine is governed by fuel injector pump built-in governor. The system controls idle speed and limits engine maximum speed. The driver controls engine speed through the position of the foot pedal assembly.
4. Fuel filters are spin-on types. The primary fuel filter has a water drain. The fuel filter/water separator has a hand fuel primer pump and a water drain.
5. Fuel may be drained from the tank through the drain port located on the bottom of the tank.
6. There is an ether quick-start system for use in cold weather. It is manually controlled via a pushbutton on the instrument panel in the cab.

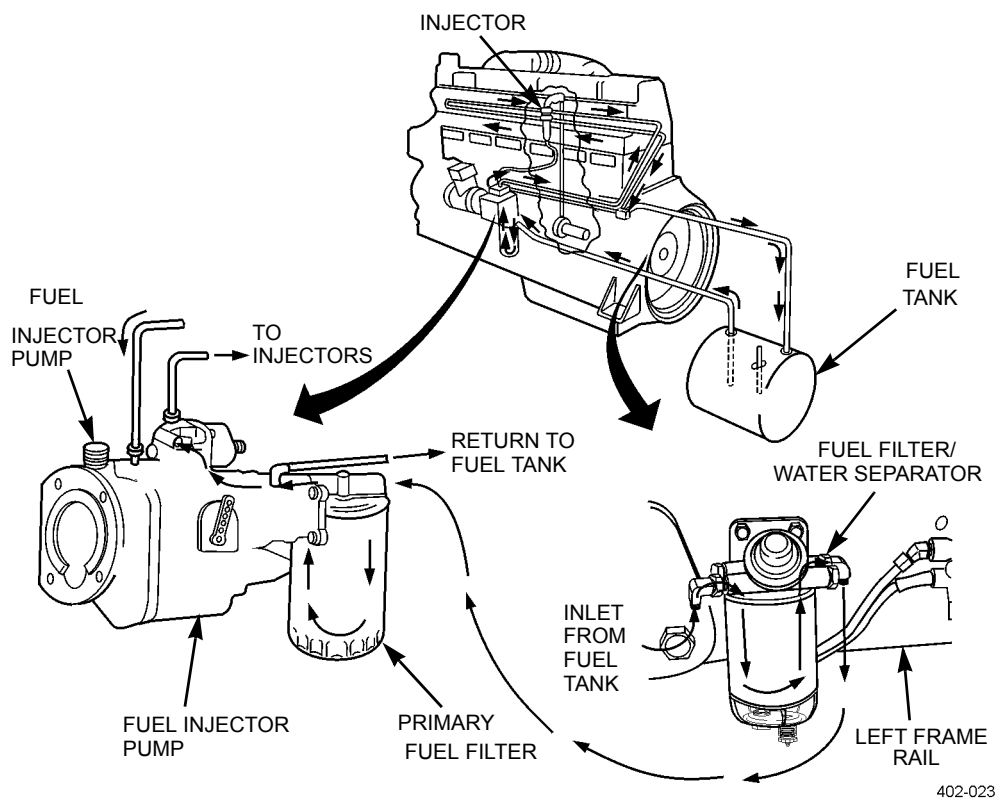

402-023

EXHAUST SYSTEM

The exhaust system removes exhaust gases from the engine through the exhaust manifold and turbocharger. The gases flow into exhaust pipes and a muffler to the atmosphere above the cab.

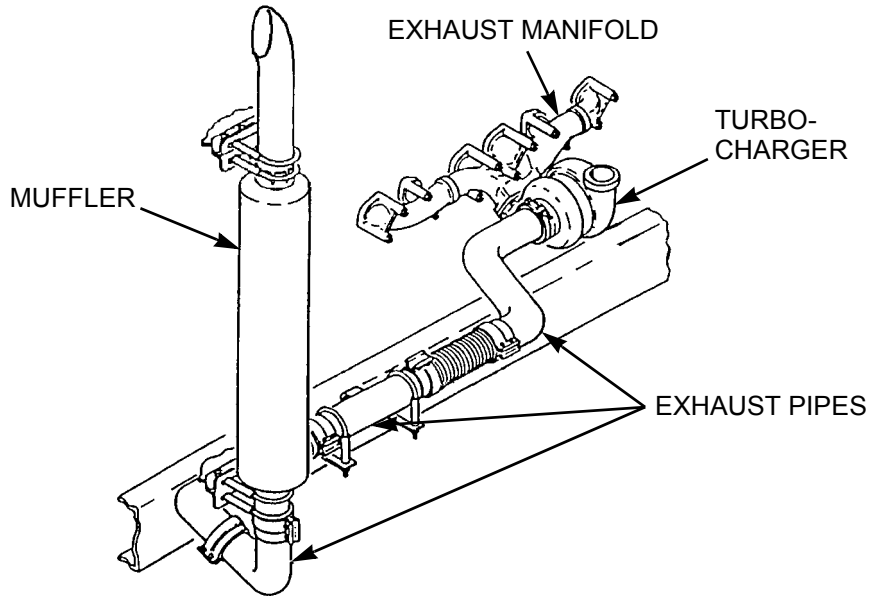

402-001

COOLING SYSTEM

The cooling system consists of one circulating pump, a remote-mounted coolant filter, one 180°F thermostat for controlling fluid flow, a transmission oil cooler, a radiator, and a belt-driven fan. The cooling system cools the engine by means of, circulating pressurized ethylene-glycol based coolant through the engine and radiator.

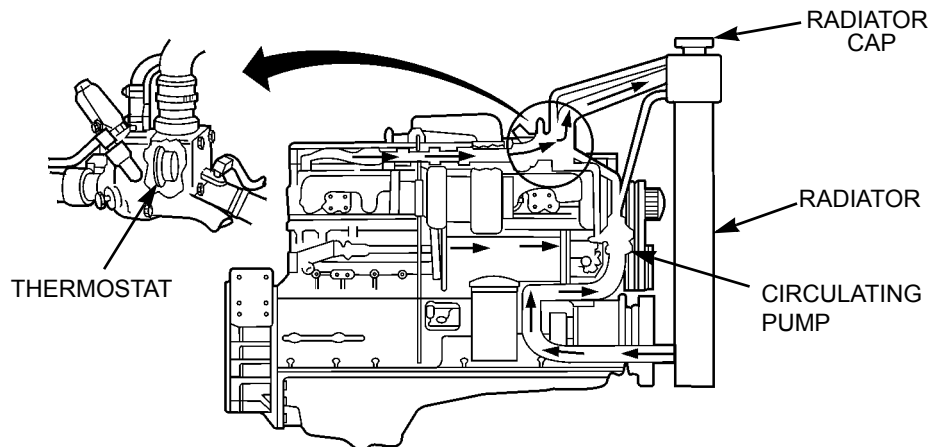

402-024

AIR SYSTEM

The air system consists of the air compressor, air dryer, air reservoirs, and various air lines. Also included in the air system are air pressure gages located on the dashboard which are used for monitoring air pressure for safe operation of all air-operated components of the vehicle. Each air tank has an automatic air/water evacuation valve. The primary air tank (wet tank) also has a pull lanyard attached for manual evacuation.

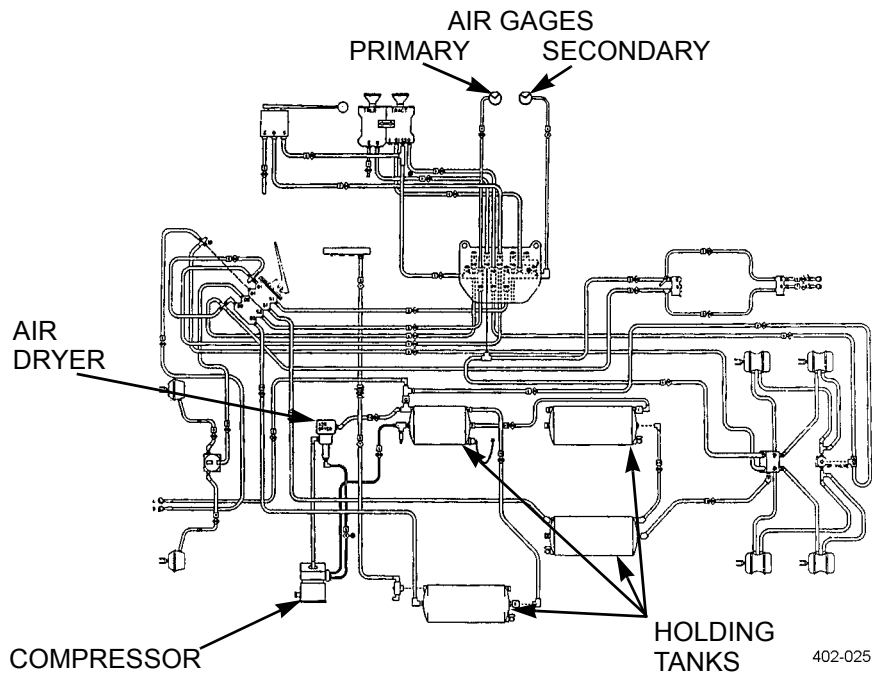

BRAKE SYSTEM

1. The dual air brake system consists of two independent air brake systems that use a single set of brake controls. Each system has its own reservoirs, plumbing, and brake chambers. The primary system operates the service brakes on the rear axle; the secondary system operates the service brakes on the front axle. On tractor-trailer configurations, service brake signals from both systems are sent to the trailer.
2. Loss of air pressure in the primary system causes the spring parking brakes to apply and stop the vehicle; front brakes will continue to be operated by secondary system air pressure. In addition, trailer brakes will be operated by the secondary system. Loss of secondary system air pressure causes the front axle brakes to become inoperative; rear service brakes and trailer brakes will be operated by the primary system.
3. The warning light and buzzer inside the cab come on if air pressure drops below 64 psi (441 kPa) in either system. If this happens, check the air pressure gages to determine which system has low air pressure. Although the vehicle's speed can be reduced using the foot brake control pedal, either the front or rear service brakes will not be operating, causing a longer stopping distance. Bring the vehicle to a safe stop and have the air system repaired before continuing.
4. If the primary system become inoperative, the spring parking brakes will automatically apply when air pressure drops to 35-45 psi (241-310 kPa).
5. The vehicle has a four-channel anti-lock brake system (ABS) and cam-operated service brakes with non-asbestos brakeshoes.
6. The M915A4 has automatically adjusting slack adjusters. On all axles, brake chambers have a stroke alert indicator which allows the operator to monitor brakeshoe wear.

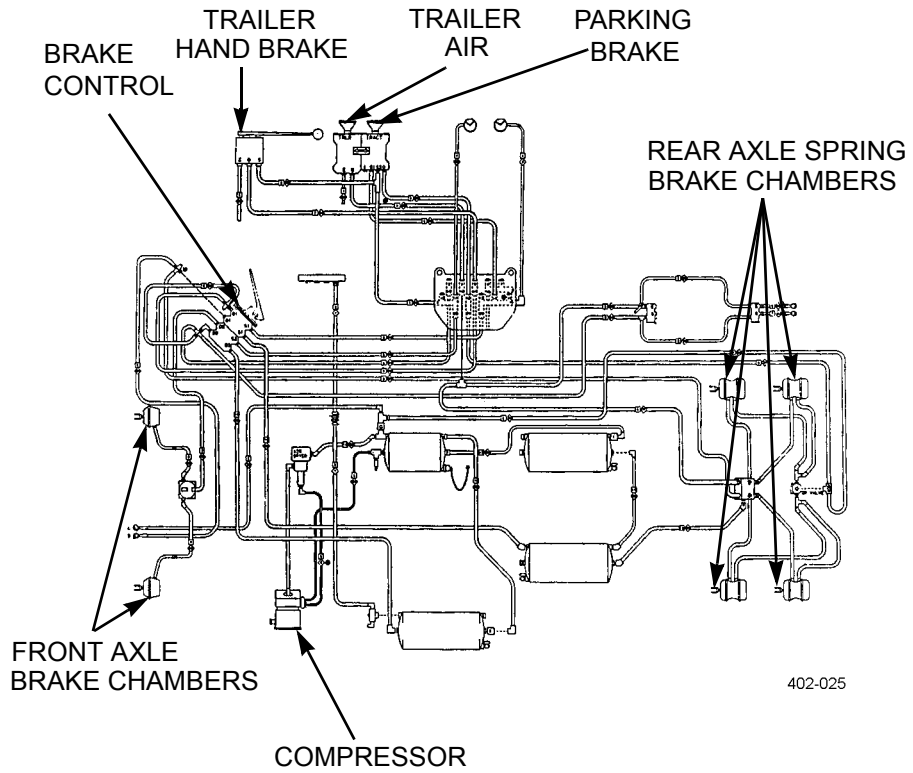

402-025

STEERING SYSTEM

1. The power steering system consists of an integral steering gear (which includes a manual steering mechanism and hydraulic control valve), hydraulic hoses, power steering pump, reservoir, and other components.
2. The power steering pump, driven by the engine, provides the power-assist for the steering system.

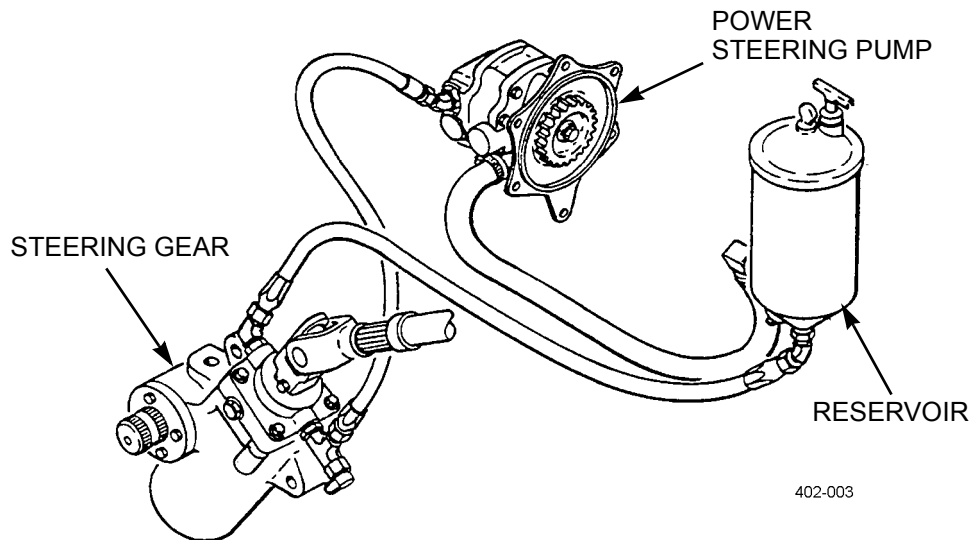

AIR CONDITIONING SYSTEM

1. The air conditioning unit is part of the heater and is mounted under the glove compartment. It is a single unit consisting of heater core, air conditioning evaporator coil, blower motor, control valves, condenser, and air ducts.
2. The system is turned on by the mode control lever on instrument panel in cab. The four-speed blower switch controls flow rate.
3. An even cab temperature is maintained by controlling the coolant flow through the heater core, or refrigerant flow through the evaporator coil.

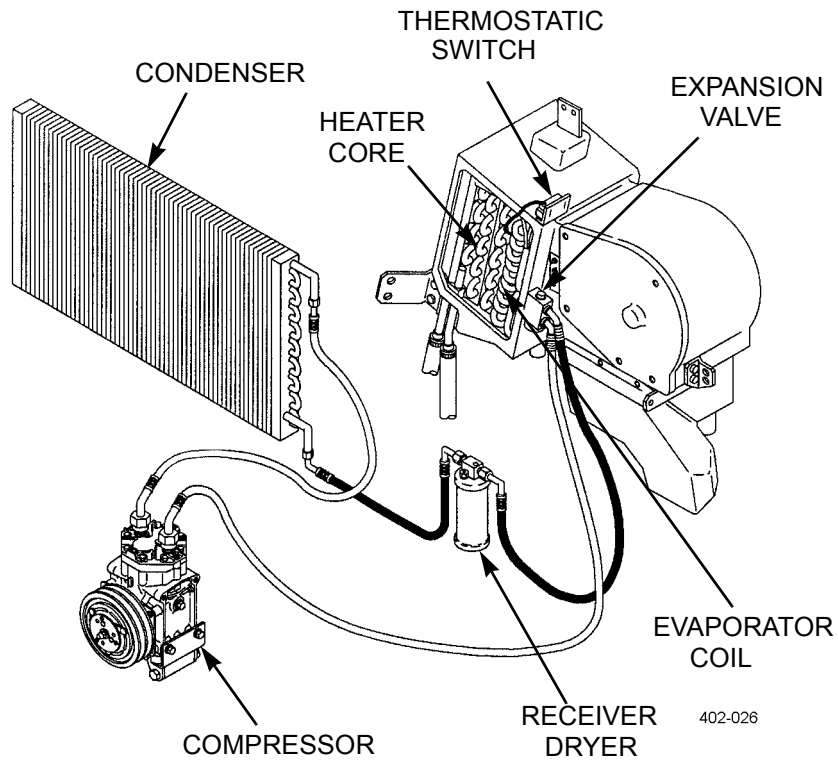

COLLISION WARNING SYSTEM (CWS)

1. The CWS consists of an antenna assembly, central processing unit, driver display unit, side sensor, side sensor display, and wiring harness.
2. The CWS is a forward and side looking radar system that transmits and receives signals reflected off of objects to the front and side of the tractor.
3. The forward looking antenna assembly determines distance, azimuth, and approximate speed of vehicle forward of the tractor.
4. The side sensor detects vehicles or objects from two to ten feet, moving or stationary, alongside the tractor.

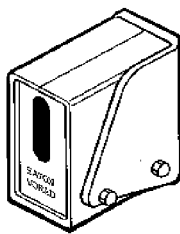

SIDE SENSOR
DISPLAY

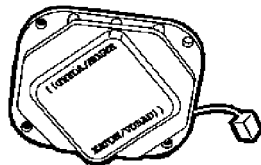

SIDE
SENSOR

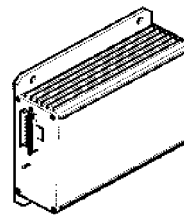

CENTRAL
PROCESSING UNIT

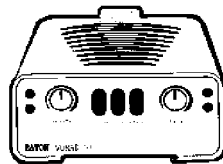

DRIVER'S
DISPLAY UNIT

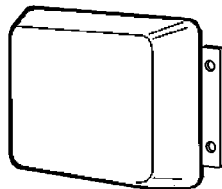

ANTENNA

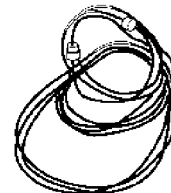

WIRING HARNESS

402-027

TRACTION CONTROL SYSTEM

The inter-axle differential lock is controlled by the air operated lever labeled INTER-AXLE DIFFERENTIAL on the driver's instrument panel. Under normal driving conditions, the control lever should be in the UNLOCK position. During poor driving conditions the control lever may be moved to the LOCK position to improve traction. When the inter-axle differential lock is applied, the drive shaft becomes a solid connection between the two rear axles.

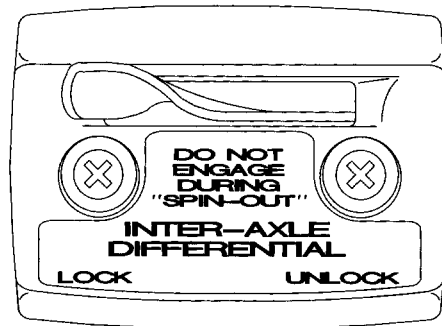

402-028

SUSPENSION SYSTEM

The suspension system is designed to provide a high degree of ground clearance and articulation while maintaining an equal load over each wheel. Ride characteristics are similar, whether loaded or unloaded.



FRONT SUSPENSION

402-931

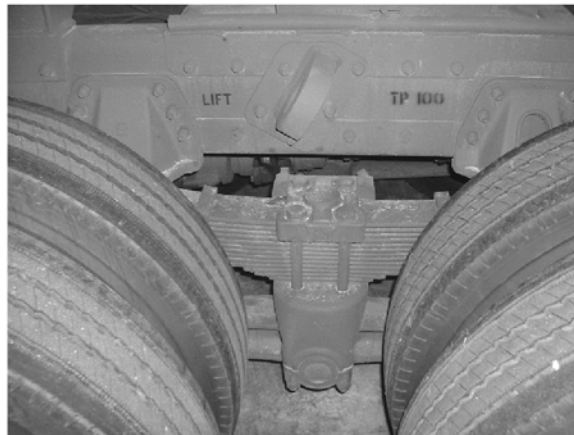

REAR SUSPENSION

402-014

END OF WORK PACKAGE

TM 9-2320-303-10

**CHAPTER 2
OPERATOR INSTRUCTIONS**

**DESCRIPTION AND USE OF OPERATOR'S
CONTROLS AND INDICATORS**

0004 00

GENERAL

Do not attempt to operate the M915A4 until becoming familiar with the location and use of all controls and indicators. The following section describes all operator controls and indicators.

DESCRIPTION AND USE OF OPERATOR'S CONTROLS AND INDICATORS - CONTINUED

0004 00

INSTRUMENT PANEL

1. **Instrument Cluster.**
 - a. **Left Gage Panel.**

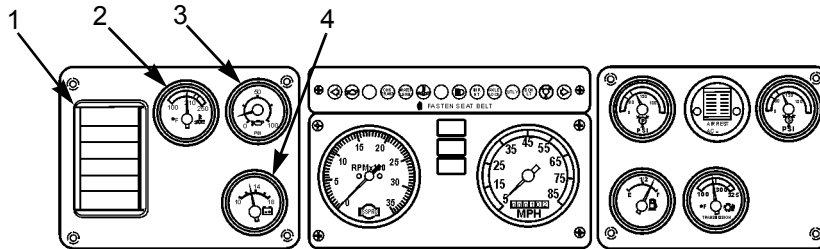

Key	Control or Indicator	Function
1	Air Vents	Vent air into cab from heater/ventilator/defroster and air conditioner. Louvered openings are adjustable. Defrost vents next to windshield are not adjustable.
2	Engine Water Temperature Gage	Registers engine coolant temperature in degrees Fahrenheit. Normal range is in green band. If needle goes into yellow band, or red band, stop and investigate cause.
3	Engine Oil Pressure Gage	Registers engine oil pressure in psi (kPa). Normal pressure at rated speed (2100 rpm) is 40-75 psi (276-517 kPa). Pressure at idle speed (600 rpm) is 5-20 psi (34-138 kPa) minimum.
4	Voltmeter	Indicates rate of battery charge or discharge in volts. <ol style="list-style-type: none"> (a) RED BAND (Left). Indicates a possible malfunction. Stop and report problem to Unit Maintenance. (b) YELLOW BAND. Indicates batteries are undercharged. Turn off all electrical circuits, if possible, and run engine at highest rpm permitted for existing conditions. If reading is still not in green band, notify Unit Maintenance. (c) GREEN BAND. Indicates normal operating range. (d) RED BAND (Right). Indicates batteries are being overcharged. Notify Unit Maintenance.

**DESCRIPTION AND USE OF OPERATOR'S
CONTROLS AND INDICATORS - CONTINUED**

0004 00

INSTRUMENT PANEL - CONTINUED

b. Center Gage Panel.

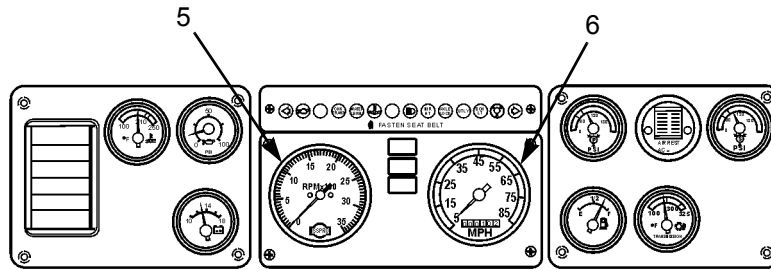

402-004

Key	Control or Indicator	Function
5	Tachometer	Registers engine speed in rpm. Maximum governed speed is 2100 rpm. Idle speed is 600 rpm.
6	Speedometer/Odometer	Registers vehicle ground speed in mph/kph (speedometer) and distance traveled (seven-digit odometer) in miles.

DESCRIPTION AND USE OF OPERATOR'S CONTROLS AND INDICATORS - CONTINUED

0004 00

INSTRUMENT PANEL - CONTINUED

c. **Right Gage Panel.**

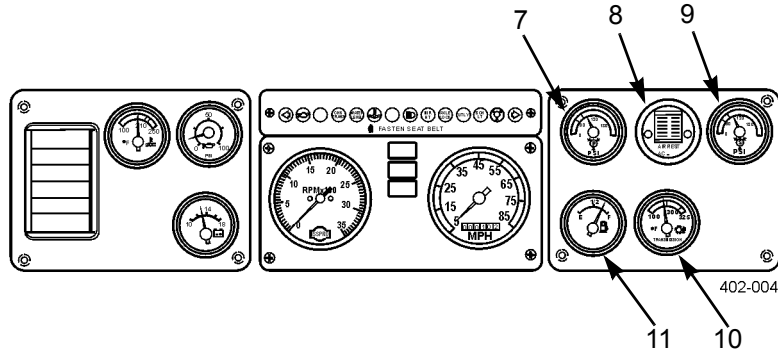

Key	Control or Indicator	Function
7	Primary Air Pressure Gage	Registers air pressure (in psi) in rear brake system. Normal operating range is in green band.
8	Air Cleaner Restriction Indicator Gage	Indicates air cleaner air flow is adequate if gage is in clear band. If restricted, gage will go into red band. Push yellow reset button to reset after air cleaner has been serviced.
9	Secondary Air Pressure Gage	Registers air pressure (in psi) in front brake system. Normal operating range is in green band.
10	Transmission Oil Temperature Gage	Indicates oil temperature in transmission. Normal range in green band. If needle goes into yellow band or red band, stop and investigate cause.
11	Fuel Gage	Indicates amount of fuel in fuel tank when ignition switch is turned on.

DESCRIPTION AND USE OF OPERATOR'S CONTROLS AND INDICATORS - CONTINUED

0004 00

INSTRUMENT PANEL - CONTINUED

2. **Upper Right Dash Panel.**

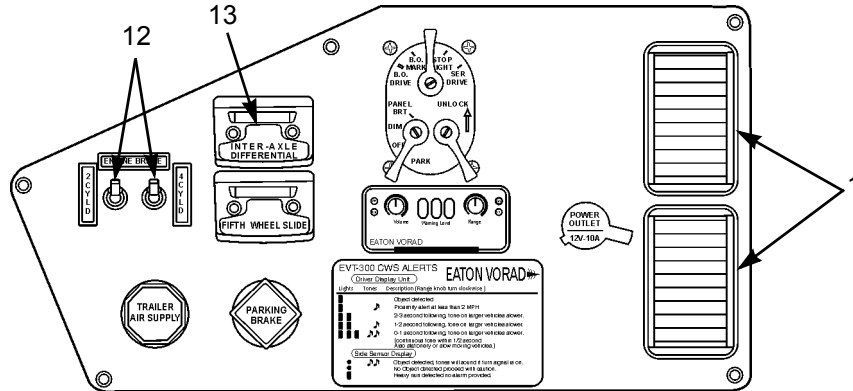

402-029

Key	Control or Indicator	Function
1	Air Vents	Vent air into cab from heater/ventilator/defroster and air conditioner. Louvered openings are adjustable.
12	Engine (Jake) Brake Selection Switches	Selects number of engine cylinders desired for braking action (two, four, or six cylinders). Turn on left switch for two cylinders, right switch for four cylinders, and both switches for all six cylinders.
13	Interaxle Lockout Control Valve Lever	Locks and unlocks driveline based on changing driving conditions. (a) LOCK. In poor traction conditions, stop vehicle and place lever in LOCK position to lock up driveline. (b) UNLOCK. When conditions are back to normal, move left to UNLOCK while vehicle is moving.

DESCRIPTION AND USE OF OPERATOR'S CONTROLS AND INDICATORS - CONTINUED

0004 00

INSTRUMENT PANEL - CONTINUED

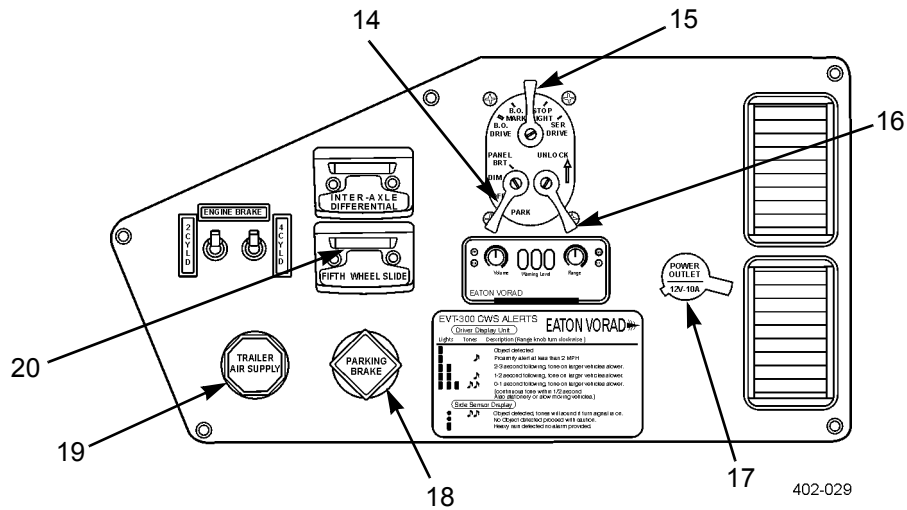

Key	Control or Indicator	Function
14	Auxiliary Switch	Four-position switch. Will not function if main light switch is OFF. Switch positions are: (a) PANEL BRT. Bright panel lights will function except if main light switch is in OFF, BO DRIVE, or BO MARKER positions. (b) PANEL DIM. Same as PANEL BRT position, but panel lights dimmer switch may dim lights. (c) PANEL OFF. Panel lights will not function. (d) PARK. When main light switch is in SER DRIVE position, headlights will be deactivated, leaving all service marker/tail lights functioning.

**DESCRIPTION AND USE OF OPERATOR'S
CONTROLS AND INDICATORS - CONTINUED**

0004 00

INSTRUMENT PANEL - CONTINUED

Key	Control or Indicator	Function
15	Main Light Switch	Five-position switch that will operate with ignition off. To engage, mechanical switch must be held in UNLOCK position (up). Switch positions are: (a) BO MARKER. Blackout marker/tail lights and blackout stop lights function. No other lights, electrical horn or CWS function. (b) BO DRIVE. Same as BO MARKER position, but blackout drive light and trailer circuit also function. (c) OFF. No lights or electrical horn function. (d) STOP LIGHT. Electrical horn and all separately controlled lights function except blackout stop lights. Powers up Collision Warning System (CWS). No marker or drive lights function. (e) SER DRIVE. Same as STOP LIGHT position, but headlight and "non-blackout" marker/tail lights function.
16	Mechanical Switch	Spring-loaded, two-position switch. Switch positions are: (a) LOCK. Down position prevents movement of main light switch. (b) UNLOCK position. Up position enables movement of main light switch. Hold lever in UNLOCK position and move main light switch to desired position.
17	12V Power Outlet	Used to connect 12VDC appliances to vehicle electrical system.
18	Parking Brake Control	Yellow diamond-shaped knob operates parking brake valve. Pull out to apply and push in to release parking brake. When released, daytime running lights (DRL) will come on.
19	Trailer Air Supply Control	Red octagonal-shaped knob supplies air to trailer air reservoirs. Push in to supply trailer air and release trailer spring brakes. Pull out to evacuate air supply and apply trailer spring brakes.
20	Fifth Wheel Slide Control Valve Lever	Disengages and engages two slide locking plungers to allow repositioning of sliding fifth wheel from inside cab. LOCK position engages slide locking plungers and locks fifth wheel to baseplate. UNLOCK position disengages slide locking plungers to allow changes to total length of tractor-trailer and changes to axle loads.

DESCRIPTION AND USE OF OPERATOR'S CONTROLS AND INDICATORS - CONTINUED

0004 00

INSTRUMENT PANEL - CONTINUED

3. **Lower Control Panel.**

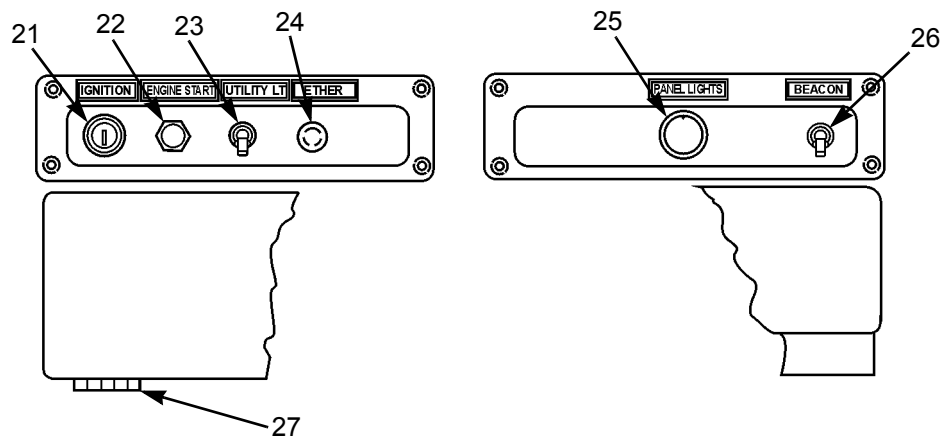

402-005

Key	Control or Indicator	Function
21	Ignition Switch	Operates gages/switches/sending units, instrument panel lights, and engine start. Turn key in switch clockwise for ON position. Turn key fully counterclockwise to activate accessories. Turn key to center vertical position to turn all systems OFF.
22	Engine Start Button	Press to energize starter solenoid. Release button as soon as engine starts.
23	Utility Light Switch	ON/OFF toggle switch controls utility lights mounted on back of cab. Up position is ON. Down position is OFF.
24	Ether Quick-Start Button	Press and release button to manually inject ether for starting in cold weather.
25	Panel Lights Control Knob	Brightens or dims instrument panel lights. Military light auxiliary switch must be in DIM position. Turn clockwise to brighten and counterclockwise to dim. Turn fully counterclockwise to shut off panel lights.
26	Beacon Light Switch	ON/OFF toggle switch controls warning light on top of vehicle. Up position is ON. Down position is OFF.
27	Diagnostic Connector	Used by maintenance personnel to connect TMDE to fault isolate vehicle systems.

DESCRIPTION AND USE OF OPERATOR'S CONTROLS AND INDICATORS - CONTINUED

0004 00

INSTRUMENT PANEL - CONTINUED

4. Lower Right Dash Panel.

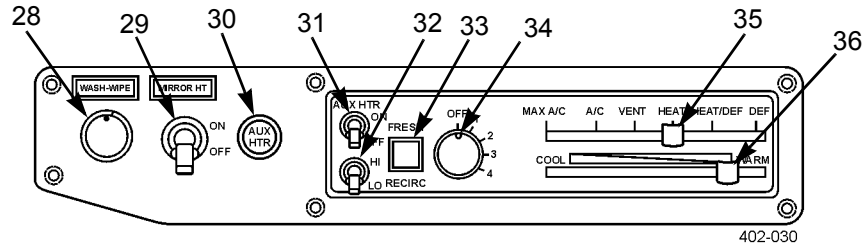

Key	Control or Indicator	Function
28	Wiper/Washer Control	Turns windshield wipers on/off. Turn clockwise one click for delayed wiper speed, two clicks for normal wiper speed and three clicks for fast wiper speed. Counterclockwise is OFF. To wash windshield, press knob in to spray water and to turn wipers on.
29	Mirror Heat Switch	ON/OFF toggle switch controls mirror heat for defrosting. Up position in ON. Down position is OFF.
30	Auxiliary Heater Indicator Light (if equipped)	Lights up when arctic heater burner is lit.
31	Auxiliary Heater Control Switch (if equipped)	Operates arctic heater. Positions are ON and OFF. When set to ON, a green light integrated into switch is illuminated.
32	HI-LO Switch (if equipped)	Controls rate of heating for arctic heater. If set at HI, heater burner will go on when coolant temperature at inlet to heater is 167°F (75°C). LO is suitable for standby operation.
33	FRESH/RECIRC Air Button	Allows A/C, VENT, and HEAT modes to be used with recirculated or fresh air. When mode control lever is at HEAT/DEF or DEF, system draws in fresh air regardless of button setting. When MAX A/C is selected, system draws recirculated air regardless of button setting.
34	Fan Switch	Controls four-speed fan. Positions are OFF, 1,2,3, and 4. Position 4 is maximum fan speed.
35	Mode Control Lever	Allows selection of modes of operation. Modes are MAX A/C, A/C, VENT, HEAT, HEAT/DEF, and DEF. Lever must be set to HEAT for arctic heater to operate.
36	Temperature Control Lever	Allows selection of a full range of temperatures from COOL to WARM.

DESCRIPTION AND USE OF OPERATOR'S CONTROLS AND INDICATORS - CONTINUED

0004 00

INSTRUMENT PANEL - CONTINUED

5. **Indicator and Warning Lamps.**

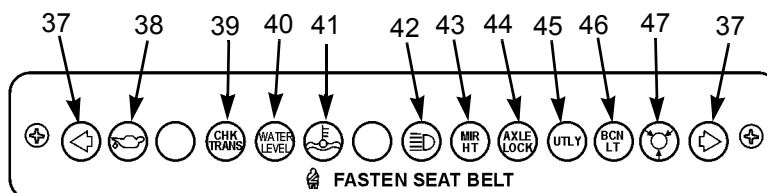

402-006

Key	Control or Indicator	Function
37	Turn Signal Indicators	Left/right green light flashes whenever outside turn signal lights are flashing. Both lights flash when four-way flashers are on.
38	Engine Oil Warning Light	Red light comes on and warning buzzer sounds when engine oil pressure is below 5 psi (34 kPa). When operating in blackout mode, only warning buzzer will sound.
39	Check Transmission (CHK TRANS) Warning Light	Red light comes on and a warning buzzer sounds when transmission temperature reaches 325°F (163°C). When operating in blackout mode, only warning buzzer will sound.
40	WATER LEVEL Light	Red light comes on and a warning buzzer sounds when engine coolant system level requires fluid. When operating in blackout mode, only warning buzzer will sound.
41	Engine Temperature Warning Light	Red light comes on and a warning buzzer sounds when engine coolant temperature is above 225°F (106°C). When operating in blackout mode, only warning buzzer will sound.
42	High Beam Indicator Light	Green light comes on when high beam headlights are on.
43	Mirror Heater (MIR HT) Indicator Light	Amber light comes on when mirror heater (defroster) is turned ON.
44	AXLE LOCK Light	Amber light comes on when interaxle differential control valve lever is set to LOCK position.
45	Utility (UTLY) Light	Amber light comes on when utility lights are turned on.
46	Beacon Light (BCN LT)	Amber light comes on when beacon warning light is turned on.
47	Low Air Pressure Warning Light	Red light comes on and warning buzzer sounds when air pressure in either section of dual system falls below 65 psi (448 kPa).

**DESCRIPTION AND USE OF OPERATOR'S
CONTROLS AND INDICATORS - CONTINUED**

0004 00

INSTRUMENT PANEL - CONTINUED

6. **Indicator and Warning Lamps.**

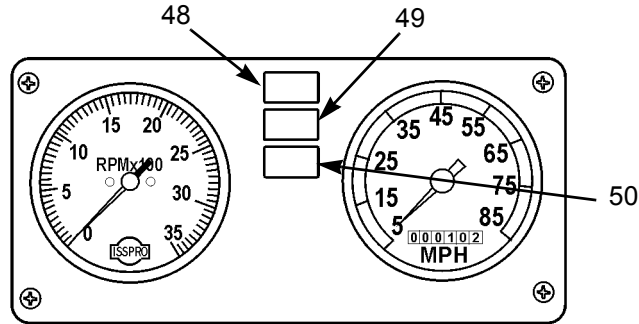

402-007

Key	Control or Indicator	Function
48	Parking Brake Indicator Light	Red light comes on when parking brake is activated.
49	Tractor ABS (TRAC ABS) Indicator Light	Red light comes on when ignition is turned ON. Light goes out after 5-10 second self-test if ABS components are working.
50	Trailer ABS Indicator Light	When coupled to ABS-equipped trailer, red light comes on when ignition is turned ON. Light goes out after 5-10 second self-test if ABS components are working.

**DESCRIPTION AND USE OF OPERATOR'S
CONTROLS AND INDICATORS - CONTINUED**

0004 00

STEERING WHEEL AND COLUMN-MOUNTED CONTROLS

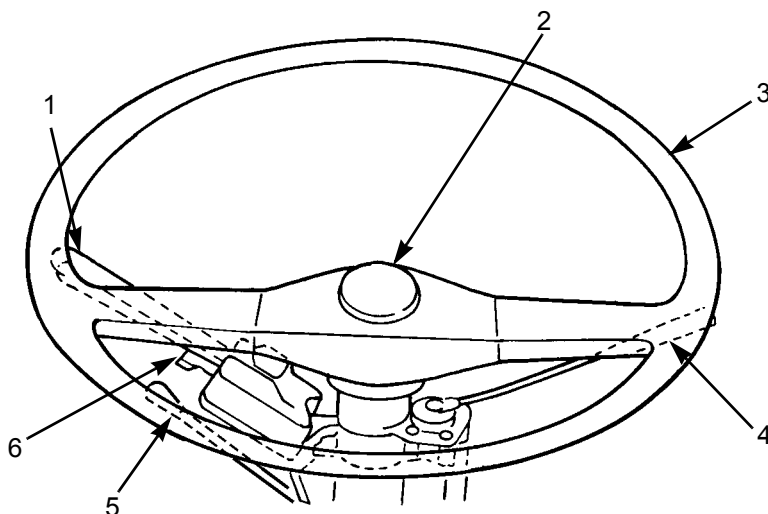

402-031

Key	Control or Indicator	Function
1	Turn Signal Lever/ Headlight Dimmer Switch	Move lever forward for right turn signal, rearward for left turn signal, and center for off. Lift end of turn signal lever to turn on high beams. Lift lever again to turn high beams off.
2	Electric Horn	Push to activate. Used instead of air horn in normal city driving.
3	Steering Wheel	Turn clockwise to turn vehicle right and counterclockwise to turn vehicle left.
4	Trailer Brake Hand Control Valve Lever	When pulled rearward, activates trailer brakes and brake lights on tractor and trailer. Used only for coupling and uncoupling.
5	Tilt Steering Wheel Control Lever	Push down on lever to change tilt of steering column and wheel. Release lever to lock tilt adjustment in position. To adjust height of steering wheel, pull up on lever. Release lever to lock height adjustment in position.
6	Hazard Signal Switch	Located under the turn signal. Move switch out (left) to activate hazard lights. Move turn signal lever forward or rearward to deactivate hazard lights.

**DESCRIPTION AND USE OF OPERATOR'S
CONTROLS AND INDICATORS - CONTINUED**

0004 00

CAB FLOOR-MOUNTED CONTROLS

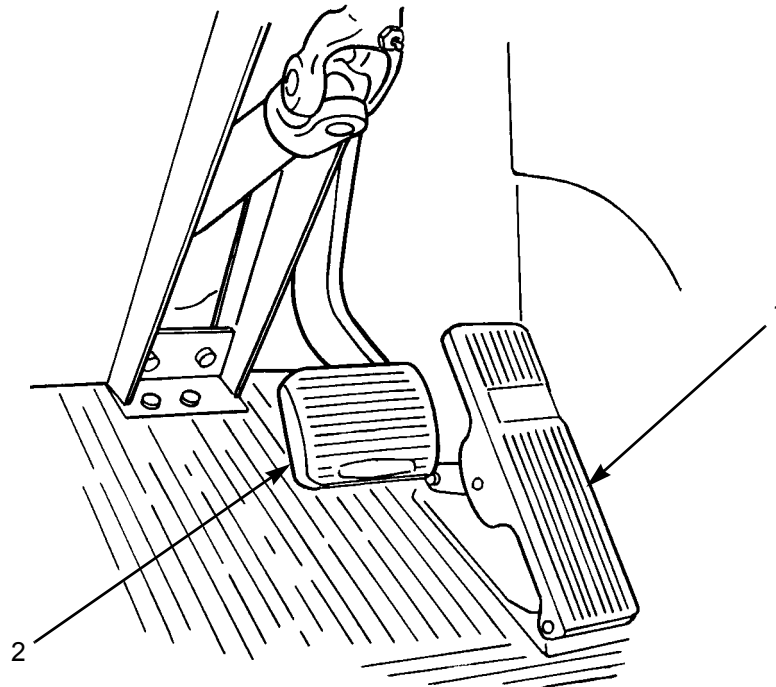

402-032

Key	Control or Indicator	Function
1	Accelerator Pedal	Depress to increase engine speed. Release to decrease engine speed.
2	Brake Pedal	Depress to apply service brakes on truck and, if properly coupled to a trailer, trailer service brakes. Release to release service brakes.

**DESCRIPTION AND USE OF OPERATOR'S
CONTROLS AND INDICATORS - CONTINUED**

0004 00

CAB FLOOR-MOUNTED CONTROLS - CONTINUED

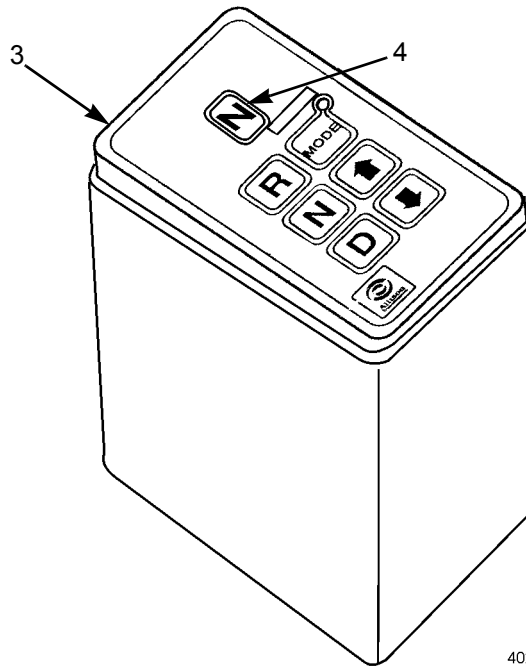

402-033

Key	Control or Indicator	Function
3	Transmission Pushbutton Shift Selector	Shifts automatic transmission. Range select positions are Reverse (R), Neutral (N), and Drive (D). In D, selection of a specific gear can be accomplished by pressing up or down arrow buttons; shifting can also be done automatically. MODE button is for unit maintenance use only.
4	Gear Indicator Digital Display	Indicates selected gear. When "D" is selected, the number 4 (or 5 speed, if equipped) will be displayed.

**DESCRIPTION AND USE OF OPERATOR'S
CONTROLS AND INDICATORS - CONTINUED**

0004 00

SEAT CONTROLS

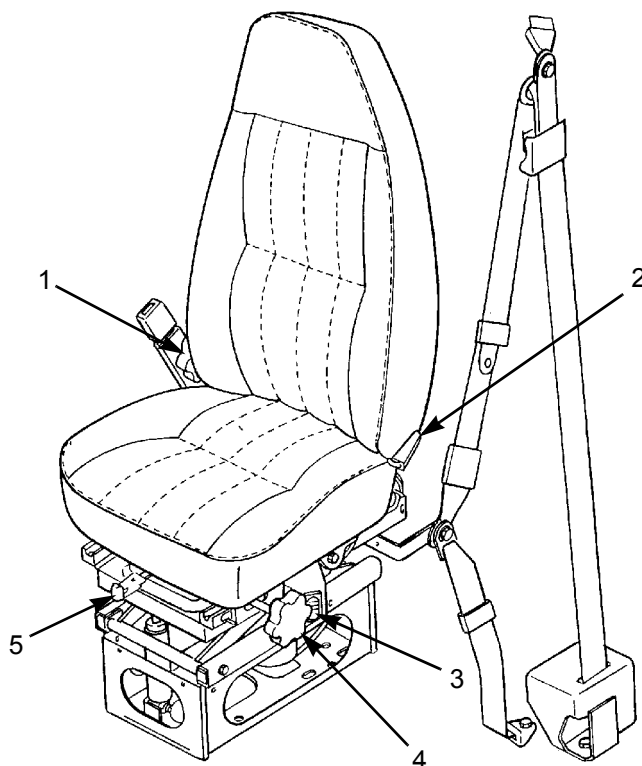

402-034

Key	Control or Indicator	Function
1	Lumbar Adjustment Knob	Controls lumbar support in seat. Rotate knob forward to increase and rearward to decrease lumbar support.
2	Seat Back Adjustment Lever	Adjusts seat back angle. Apply or remove pressure from seat back and hold lever rearward to adjust.
3	Seat Height Adjustment Control Valve Switch	Vehicle air pressure must be above 60 psi (414 kPa) to operate switch. Push top of switch to raise seat and bottom of switch to lower seat.
4	Seat Cushion Tilt Adjustment Knob	Rotate knob to increase or decrease seat tilt.
5	Fore and Aft Seat Adjustment Lever	Three-position lever moves seat forward or backward. Right position locks seat in place. Moving lever all the way left adjusts seat. Traveling position is center position which provides a shock-absorbing effect.

**DESCRIPTION AND USE OF OPERATOR'S
CONTROLS AND INDICATORS - CONTINUED**

0004 00

SEAT CONTROLS - CONTINUED

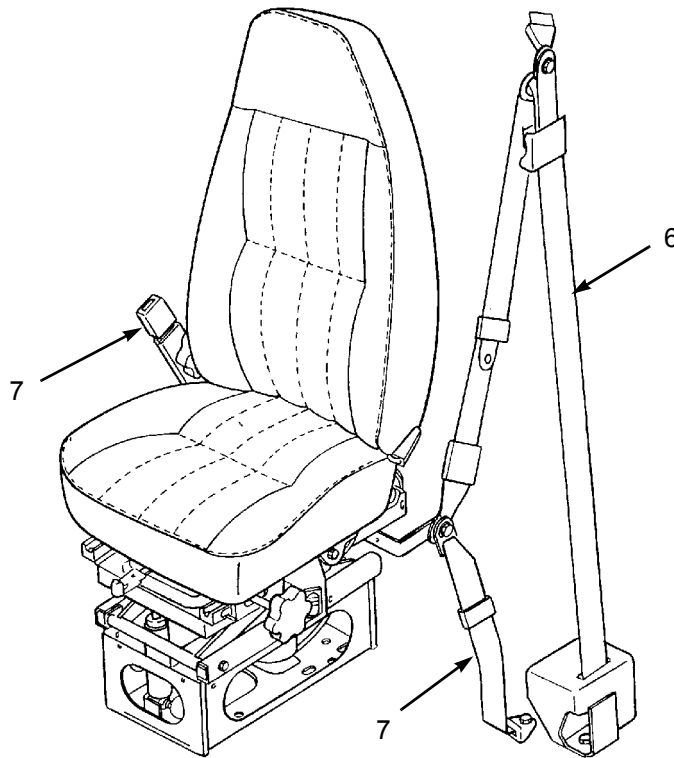

402-034

Key	Control or Indicator	Function
6	Seat Belt	Three-point belt locks into tether belt.
7	Tether Belts	Adjustable belts located on both sides of seat. Inboard tether belt provides lock for seat belt.

DESCRIPTION AND USE OF OPERATOR'S CONTROLS AND INDICATORS - CONTINUED

0004 00

COLLISION WARNING SYSTEM (CWS)

1. **CWS Driver's Display Unit.**

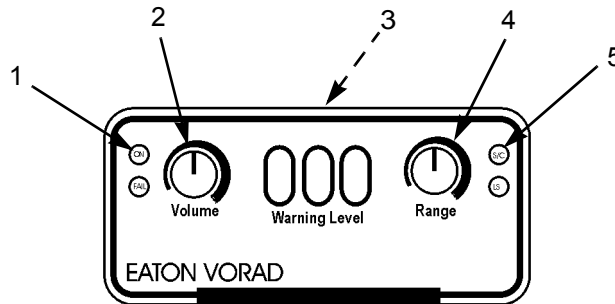

402-038

Key	Control or Indicator	Function
1	Green, Power On	Illuminates when ignition is turned on, military light switch is in STOP LT or SER DRIVE, and the power-on LED test is complete.
2	Volume Control and Power On/Off	When pushed in until a distinctive click is heard and/or felt, turns the power ON or OFF. Adjusts the volume of the driver display unit speaker. Activates "Failure Display Mode" when the knob is pressed and held for five seconds and released.
3	Speaker	Located under the top cover of the driver display unit. Sounds audible tones to alert the driver of a possible hazard. May be set to limit the volume to a minimum level.
4	Range Control and Accident Recorder Selection	When rotated, this control provides detection range adjustment of the first alert between 3 and 2.125 seconds. Function may be configured to prevent range adjustment control. Accident reconstruction is initiated by pushing and holding this knob for 5 seconds thereby freezing the most recent data in half of the allocated memory.
5	Green, Smart Cruise/Accident Reconstruction	Light comes on during power-up and LED test. Function not used.

DESCRIPTION AND USE OF OPERATOR'S CONTROLS AND INDICATORS - CONTINUED

0004 00

COLLISION WARNING SYSTEM (CWS) - CONTINUED

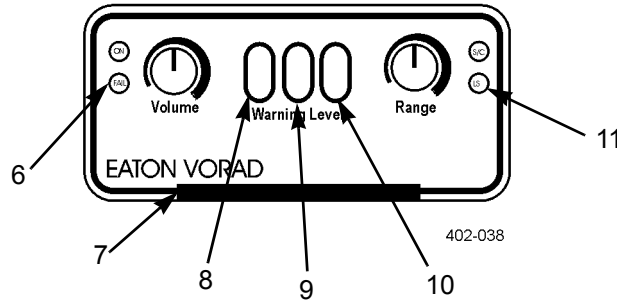

Key	Control or Indicator	Function
6	Red, System Failure	Lights when a problem has been detected in the forward looking radar system. A pattern of flashes blink out the faults that are stored in memory when activated by holding in the volume control knob for 5 seconds.
7	Driver's Identification Card Slot	Not used.
8	Yellow	This indicator illuminates when an object is detected within the system's maximum range. Maximum range is 350 feet on straight roads and is reduced on curved roads by the road turn radius. It also illuminates when the proximity alarm threshold is crossed.
9	Orange, Accompanied with Yellow	This indicator illuminates when an object is detected within a 3 second interval of vehicle opening or closing, 1 to 2 seconds following interval with vehicle opening and no tone, and 1 to 2 seconds following interval with vehicle closing accompanied by a tone.
10	Red, Accompanied with Yellow and Orange	This indicator illuminates when an object is detected at <1 second with vehicle opening and no tone with vehicle closing accompanied by audible tones. At a 1/2 second or less following interval opening and closing, the tones are repeated, twice per second.
11	Light Sensor	Photo sensor that senses ambient lighting and adjusts intensity of the indicator lights accordingly (i.e., increases brightness of indicator lights in daytime and decreases brightness of indicator lights at nighttime).

**DESCRIPTION AND USE OF OPERATOR'S
CONTROLS AND INDICATORS - CONTINUED**

0004 00

COLLISION WARNING SYSTEM (CWS) - CONTINUED

Table 1. Miscellaneous Tones.

Light/Tones	Description
Fail, One Low Tone	Sounded when the system diagnostics detect a failure.
One Tone	Each time the volume control is turned a single tone is sounded.

**DESCRIPTION AND USE OF OPERATOR'S
CONTROLS AND INDICATORS - CONTINUED**

0004 00

COLLISION WARNING SYSTEM (CWS) - CONTINUED

2. **CWS Side Sensor Display.**

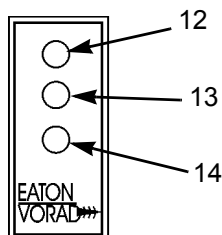

402-039

Key	Control or Indicator	Function
12	Red, Vehicle Detected	Indicator light that illuminates after objects have been detected by the side sensor. When the right turn signal is activated and the side sensor detects an object, the red indicator light comes on and the driver display unit speaker sounds a double tone. The tone is sounded only once per activation of the turn signal. Lights if a failure of the side sensor occurs and if the criteria for heavy rain is met.
13	Light Sensor	Photo sensor that senses ambient light and adjusts intensity of the indicator lights accordingly (i.e., increases brightness of indicator lights in daytime and decreases brightness of indicator lights at nighttime).
14	Yellow, No Vehicle Detected	Indicator light stays on when no objects are detected by the side sensor.
12/ 14	Red and Yellow	Indicates the side sensor is temporarily unable to detect objects in heavy rain.

**DESCRIPTION AND USE OF OPERATOR'S
CONTROLS AND INDICATORS - CONTINUED**

0004 00

ADDITIONAL CONTROLS AND INDICATORS

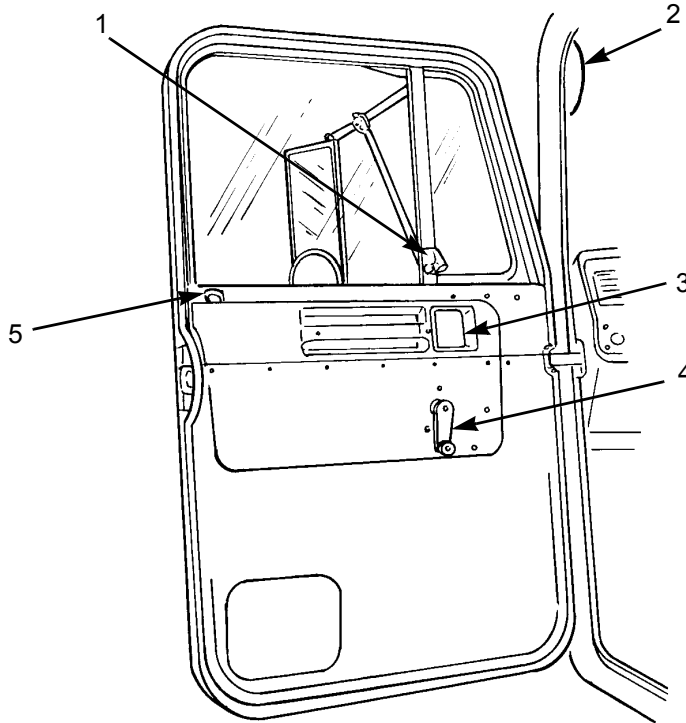

402-035

Key	Control or Indicator	Function
1	Cab Vent Window Handle	Push button and raise handle to unlock window. Push out on handle to open window. Pull handle in to close window. Lower handle to lock window.
2	Air Horn Cable	Pull cable to activate air horn. Release cable to deactivate air horn.
3	Door Opening Handle	Pull handle to open cab door.
4	Door Window Glass Regulator Handle	Turn driver side handle clockwise to lower left window and counterclockwise to raise left window. Turn passenger side handle counterclockwise to lower right window and clockwise to raise right window.
5	Door Lock Button	Push button down to lock door. To unlock, either pull door opening handle or unlock from outside with ignition key.

**DESCRIPTION AND USE OF OPERATOR'S
CONTROLS AND INDICATORS - CONTINUED**

0004 00

ADDITIONAL CONTROLS AND INDICATORS - CONTINUED

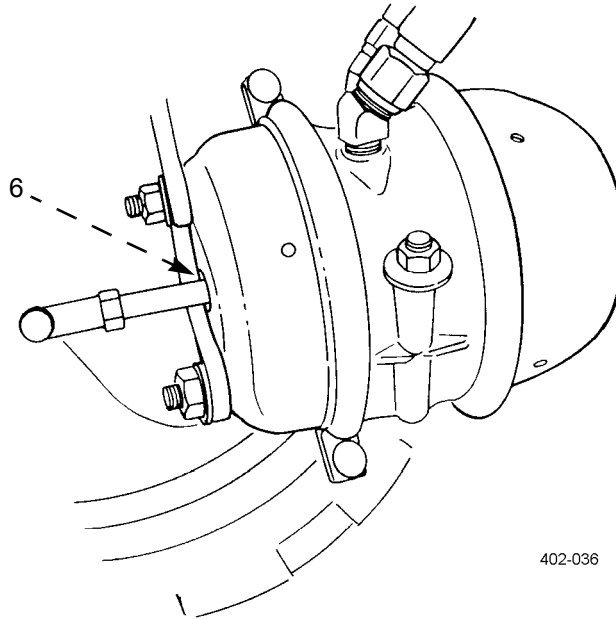

Key	Control or Indicator	Function
6	Stroke Alert Indicator	Bright orange band painted on service pushrod of all brake chambers. When visible, notify Unit Maintenance to perform stroke adjustment or major brake service.

**DESCRIPTION AND USE OF OPERATOR'S
CONTROLS AND INDICATORS - CONTINUED**

0004 00

ADDITIONAL CONTROLS AND INDICATORS - CONTINUED

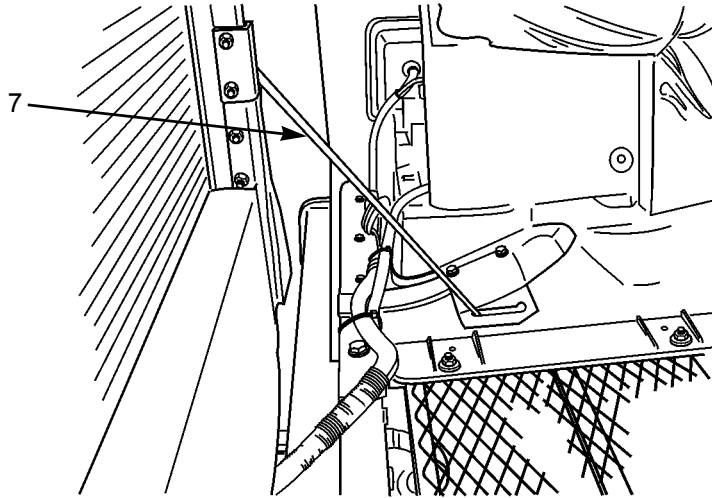

402-008

Key	Control or Indicator	Function
7	Hood Prop	When installed, prevents hood from accidentally closing.

**DESCRIPTION AND USE OF OPERATOR'S
CONTROLS AND INDICATORS - CONTINUED**

0004 00

ADDITIONAL CONTROLS AND INDICATORS - CONTINUED

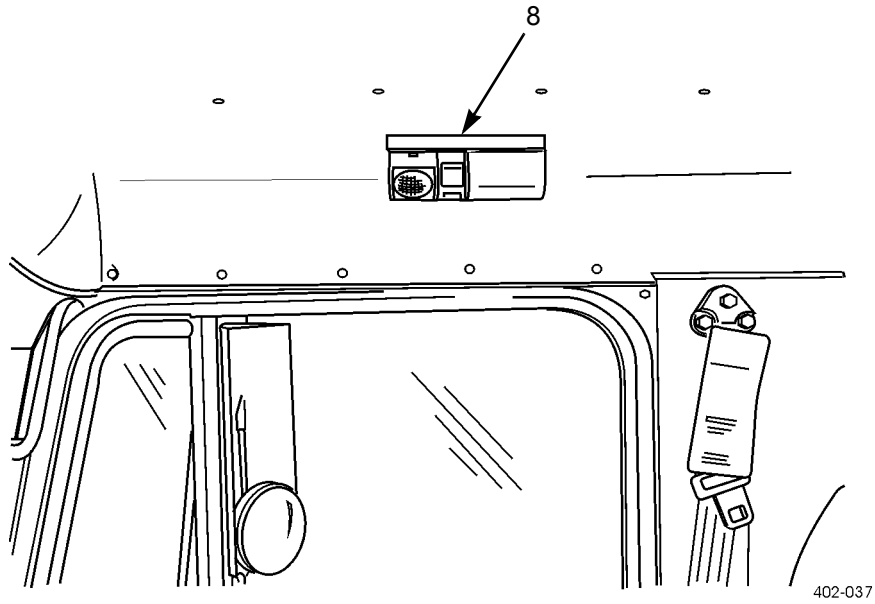

402-037

Key	Control or Indicator	Function
8	Interior Lights	Provide interior cab lighting.

**DESCRIPTION AND USE OF OPERATOR'S
CONTROLS AND INDICATORS - CONTINUED**

0004 00

ADDITIONAL CONTROLS AND INDICATORS - CONTINUED

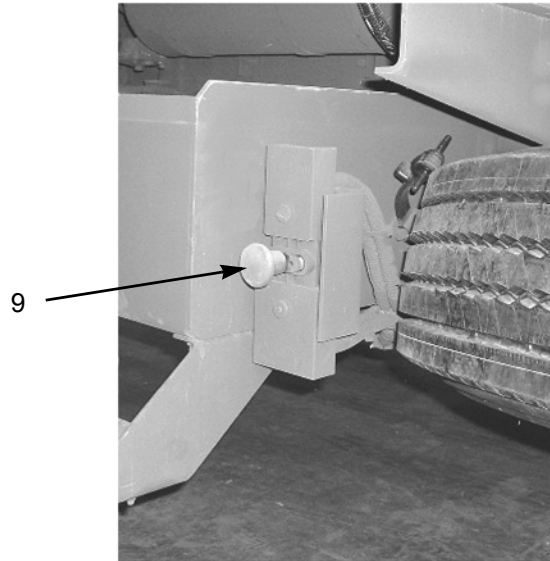

402-009

Key	Control or Indicator	Function
9	Master Battery Switch	Located on rear of battery box, connects batteries to vehicle electrical system. Push in for ON, pull out for OFF. When off, yellow band is visible on switch.

**DESCRIPTION AND USE OF OPERATOR'S
CONTROLS AND INDICATORS - CONTINUED**

0004 00

ADDITIONAL CONTROLS AND INDICATORS - CONTINUED

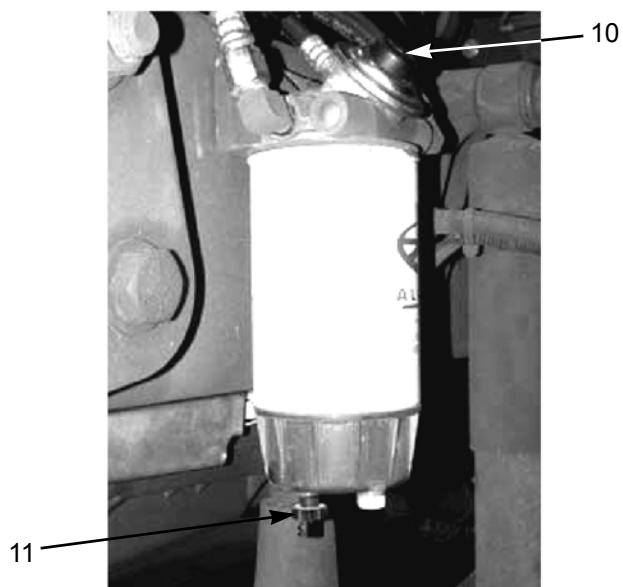

402-040

Key	Control or Indicator	Function
10	Fuel/Water Separator Pump Valve	Used to prime fuel system in the event engine fails to start.
11	Drain Valve	Used to drain water and sediment from fuel system.

**DESCRIPTION AND USE OF OPERATOR'S
CONTROLS AND INDICATORS - CONTINUED**

0004 00

ADDITIONAL CONTROLS AND INDICATORS - CONTINUED

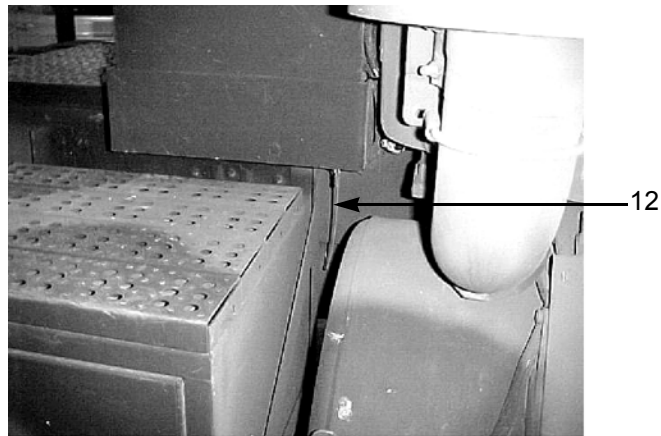

402-041

Key	Control or Indicator	Function
12	Primary Air Tank Pull Lanyard	Used to manually evacuate primary air tank.

**DESCRIPTION AND USE OF OPERATOR'S
CONTROLS AND INDICATORS - CONTINUED**

0004 00

ADDITIONAL CONTROLS AND INDICATORS - CONTINUED

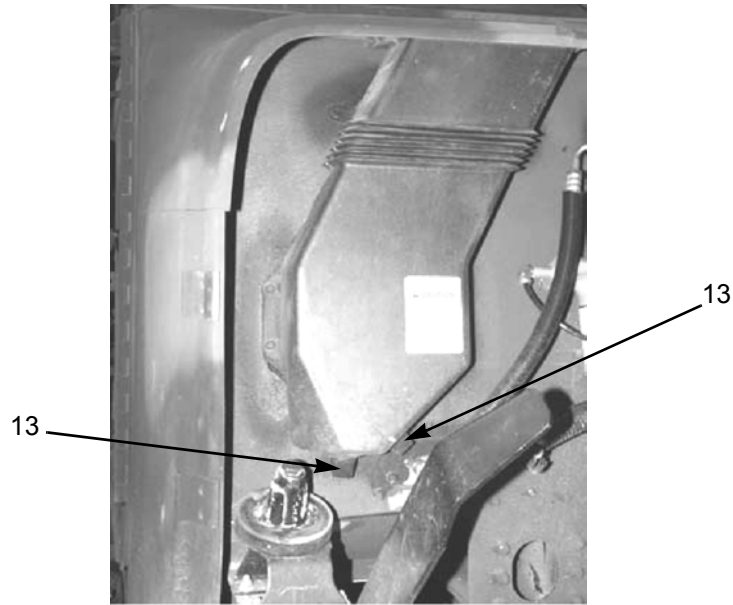

402-042

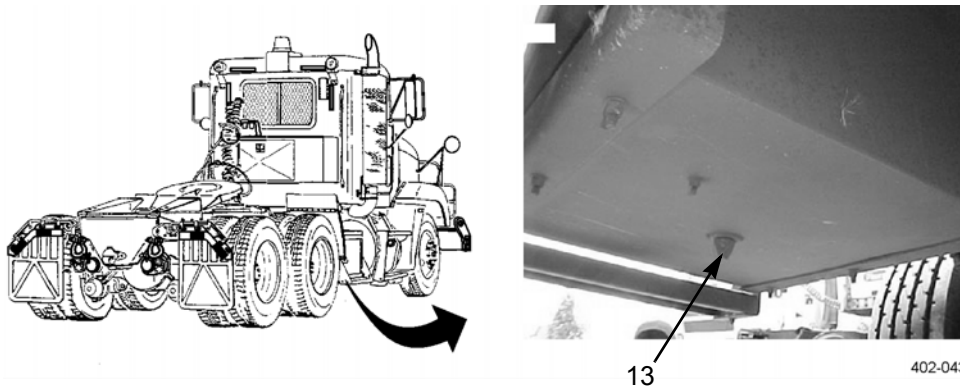

402-043

Key	Control or Indicator	Function
13	Drain Bulbs	Squeeze rubber bulb to drain accumulated moisture and dirt.

**DESCRIPTION AND USE OF OPERATOR'S
CONTROLS AND INDICATORS - CONTINUED**

0004 00

ADDITIONAL CONTROLS AND INDICATORS - CONTINUED

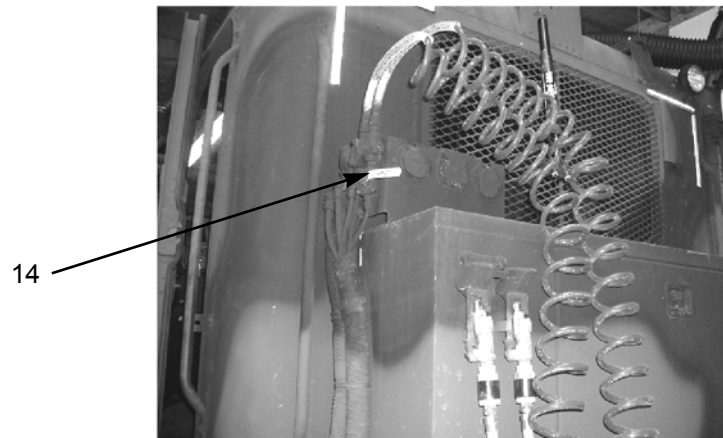

402-011

Key	Control or Indicator	Function
14	Air Flow Valve Lever	When the lever is in horizontal position, air flow is directed to both rear emergency and service air hose gladhands. When lever is in vertical position, air flow is directed to rear emergency gladhand only.

**DESCRIPTION AND USE OF OPERATOR'S
CONTROLS AND INDICATORS - CONTINUED**

0004 00

ADDITIONAL CONTROLS AND INDICATORS - CONTINUED

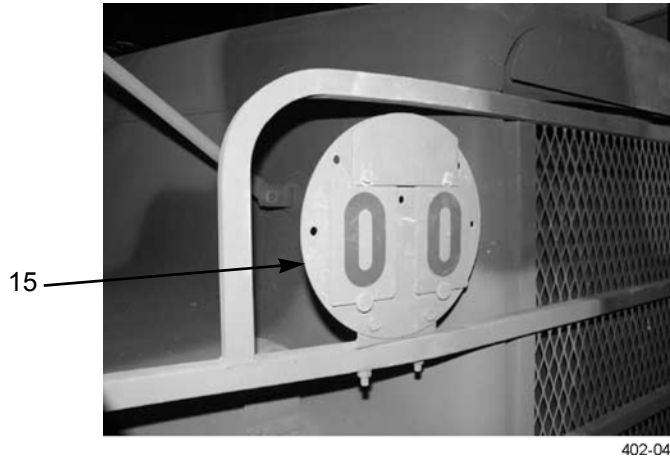

Key	Control or Indicator	Function
15	Military Classification Sign	Removable number placards mount to sign bracket.

**DESCRIPTION AND USE OF OPERATOR'S
CONTROLS AND INDICATORS - CONTINUED**

0004 00

ADDITIONAL CONTROLS AND INDICATORS - CONTINUED

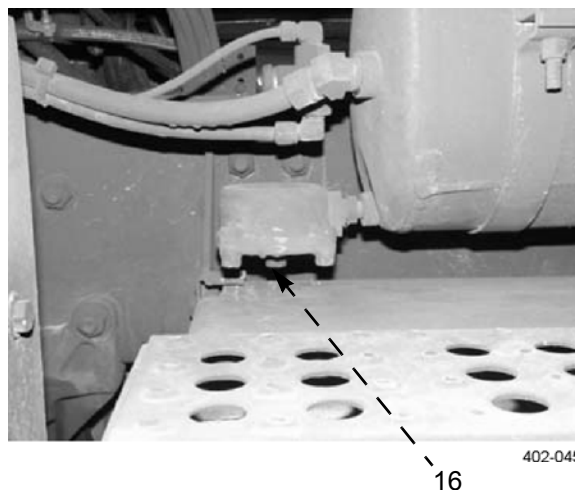

Key	Control or Indicator	Function
16	Auto Drain Valves	Mounted on each air reservoir. Depress rubber pin to manually evacuate.

END OF WORK PACKAGE

GENERAL**WARNING**

This vehicle has been designed to operate safely and efficiently within the limits specified in this TM. Operation beyond these limits is prohibited in accordance with AR 70-1 without written approval from: Commander, U.S. Army Tank-automotive and Armaments Command, ATTN:AMSTA-LC-AF-IM, Warren, MI 48397-5000.

This work package contains instructions for safely operating the M915A4 under usual conditions. Unusual conditions are defined and described in WP 0006 00 of this chapter.

INITIAL ADJUSTMENTS, BEFORE USE, AND SELF-TESTS

1. Place master battery switch to ON.
2. Perform *Before* operation Preventive Maintenance Checks and Services (PMCS) (WP 0012 00).
3. Change military load classification (5), if necessary.
4. Adjust side mirrors (3). If necessary, loosen two nuts (2) and moving side mirror to proper position. Tighten two nuts.

CAUTION

DO NOT attempt to adjust spotter mirrors without loosening screws. Attaching screw may become loose and result in loss of spotter mirror.

NOTE

- Adjust left mirror so driver can see front of vehicle.
 - Adjust right mirror so driver can see right side of vehicle from front to rear.
5. Adjust spotter mirrors (1) by loosening three screws (4) and moving spotter mirror to proper position. Tighten three screws.

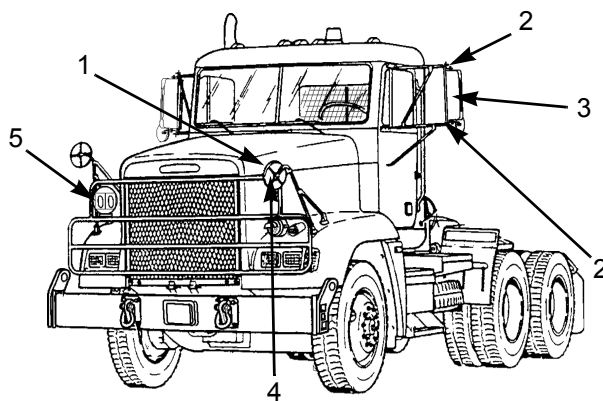

402-020

INITIAL ADJUSTMENTS, BEFORE USE, AND SELF-TESTS - CONTINUED**WARNING**

Serious injury may result if head clearance is not adequate while sitting in seat. Before driving or riding in vehicle, ensure there is adequate clearance at maximum upward travel of seat.

6. Occupy and adjust seat. Check spotter mirror adjustment.

WARNING

Ensure that steering wheel adjustment control lever is in locked (neutral) position before driving truck. NEVER try to adjust tilt or height of steering wheel while driving. Failure to follow this warning may cause death or injury to personnel.

7. Adjust steering wheel.

WARNING

Use of seat belts while operating vehicle is mandatory. Fasten belt BEFORE driving. Trying to fasten three-point seat belt while driving creates a hazardous condition. Failure to follow this warning may result in death or injury to personnel.

8. Adjust tether belt.
 - a. Loosen tether belt (11) and turn buckle (6) at a right angle to webbing. Pull buckle away from inner webbing.
 - b. Tighten tether belt (11) to proper tension. Ensure that movement of seat suspension is not restricted.
9. Fasten seat belt.
 - a. Slowly pull link (9) out of retractor (10) and across lap far enough to engage buckle (6). If retractor locks too soon, allow belt to retract slightly and then pull slowly.
 - b. Push link (9) into buckle (6).
 - c. Position shoulder strap (8) diagonally across chest.

NOTE

- If engaging Komfort Loc®, allow no more than 1 in. (2.5 cm) between chest and shoulder strap.
- Komfort Loc® will automatically release if pressure is applied to shoulder strap.
- d. If desired, engage Komfort Loc® (7) by pulling on shoulder strap (8) and pressing Komfort Loc® lever up.

INITIAL ADJUSTMENTS, BEFORE USE, AND SELF-TESTS - CONTINUED

- e. To release seat belt, press release button on buckle (6). If Komfort Loc® (7) was engaged, give shoulder strap (9) a quick downward tug to release.

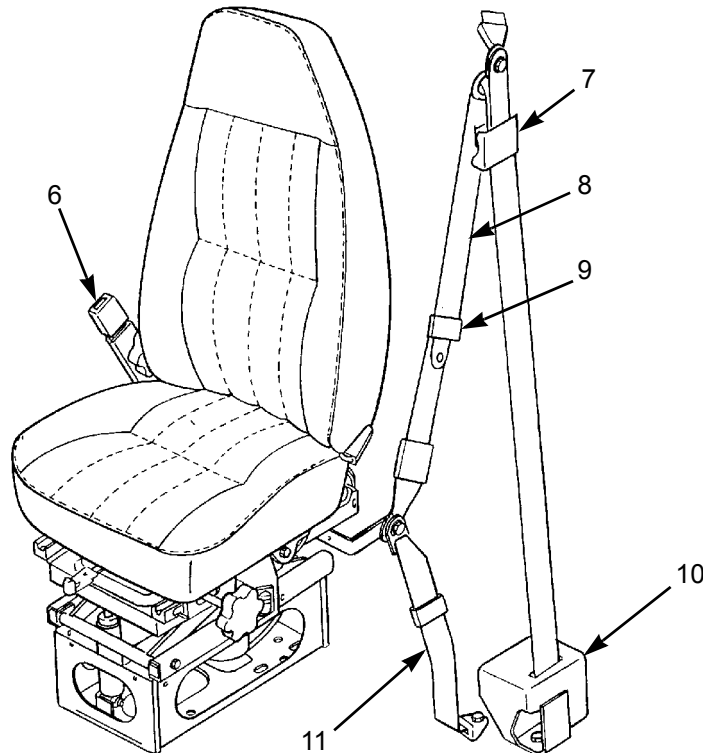

402-034

OPERATING PROCEDURES**Start Engine****NOTE**

- Refer to WP 0004 00 for the location of instrument panel controls and indicators.
 - Perform steps 9 through 11 if outside temperature is at or below 32°F (0°C).
1. Ensure that parking brake is applied.
 2. Ensure that all accessories are off, engine brake switches are in OFF (Down) position, and interaxle lockout control valve lever is in UNLOCK position.

OPERATING PROCEDURES - CONTINUED**Start Engine - Continued****NOTE**

Low air warning light and buzzer will stay on if air pressure is below green band. Warning light and buzzer will go off after engine is started and 60 psi in air system is achieved.

3. Turn ignition switch to ON position.
4. Warning buzzer, engine oil warning, CHK TRANS, PARK BRAKE (if applied), and ABS light(s) will come on.
5. ABS light(s) will go off after passing a 5-10 second self-test.

CAUTION

DO NOT operate starter motor for more than 30 seconds at a time. After 30 seconds, allow starter motor to cool for at least two minutes before attempting to start engine again. Excessive heating of starter motor may result in damage or early starter failure.

NOTE

Engines radiate electrical emissions when running and can interfere with communications equipment. Stay at least 1.5 meters away from communications equipment with engine running.

6. Press engine start button.
7. If no malfunctions exist, engine oil warning, light and buzzer will go off after approximately 7 seconds.
8. When engine starts, release engine start button. If engine fails to start perform troubleshooting.
9. Perform steps 1 through 5.

CAUTION

- Never press ether quick-start button unless cranking engine simultaneously. Buildup of ether fumes may result in combustion in intake manifold.
 - DO NOT operate starter motor for more than 30 seconds at a time. After 30 seconds, allow starter motor to cool for at least two minutes before attempting to start engine again. Excessive heating of starter motor may result in damage or early starter failure.
10. Press engine start button and at the same time press ether quick-start button once.
 11. When engine starts, release engine start button.

OPERATING PROCEDURES - CONTINUED

Start Engine - Continued

CAUTION

DO NOT run engine above idle speed until oil pressure gage indicates at least 5-20 psi (34.4- 138 kPa) at idle speed.

12. Do not run engine above 600 rpm until normal oil pressure (15 psi) is indicated on engine oil pressure gage.
13. Monitor gages and indicators. If after ten seconds there is no indication of oil pressure, shut down engine and perform troubleshooting.

Power Up Collision Warning System (CWS)

NOTE

When engine is running and operating within 9.5 meters of communications equipment, collision warning system (CWS) may not operate properly.

1. Turn main light switch to STOP LIGHT or SER DRIVE position.
2. One tone will be heard and driver side sensor display lights will illuminate for approximately 15 seconds.
3. After self-test, green power on light (1) on driver's display should remain on.
4. Side sensor display should have appropriate light(s) on.

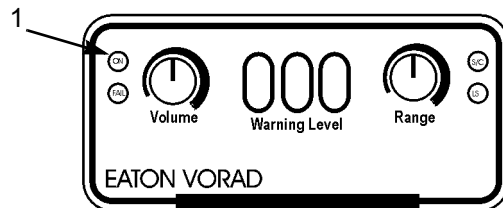

402-038

OPERATING PROCEDURES - CONTINUED**Operate Transmission**1. **Transmission Ranges.**

- a. **Reverse (R).** Reverse (R) is used to back up the vehicle. Vehicle must be brought to a complete stop before shifting from a forward range to R or visa versa. Light on panel will illuminate and the digital display will display R when reverse is attained.

CAUTION

DO NOT allow truck to coast in Neutral (N). This can result in severe transmission damage. When in N, engine braking is not available.

- b. **Neutral (N).** Neutral (N) is the normal transmission position when vehicle is not in use. Use N to start engine, to check vehicle accessories, and for extended periods of engine idling. Light on panel will illuminate and the digital display will display N when transmission is in neutral. Transmission ECU automatically selects NEUTRAL when starting vehicle.

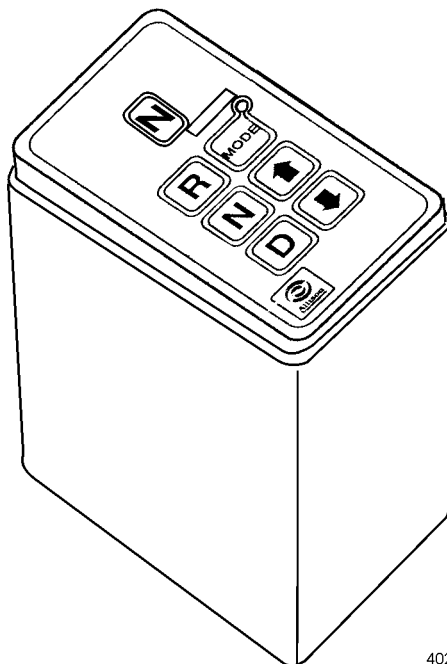

402-033

- c. **Drive (D).** When placed in Drive (D), the transmission starts out in 1st gear and automatically progresses to the 4th gear (or 5th gear, if equipped). During slow-down, transmission automatically downshifts. Light on panel will illuminate and the digital display will display the highest forward gear attainable.
 - (1) To select a specific forward gear, press the up or down arrow pushbuttons.

OPERATING PROCEDURES - CONTINUED**Operate Transmission - Continued****NOTE**

Even when a lower gear is selected, transmission may not downshift until vehicle speed is reduced.

- (2) The digital display will display the selected gear.
 - (3) The greater the need for engine power or engine braking power, the lower the gear selection should be.
 - (4) Gears 2, 3 and 4 (if equipped with 5th gear). Use 2nd, 3rd, or 4th (if equipped with 5th gear) gears when road, load or traffic conditions make it preferable to use lower gears.
 - (5) Gear 1. 1st gear is the low gear used for pulling through mud, snow or going up steep grades. This position also offers maximum engine braking power.
 - (6) When conditions improve, return vehicle to Drive (D).
2. **Operation.**
- a. Depress brake pedal and hold.
 - b. Release parking brake.
 - c. Release trailer brakes, if towing.
 - d. Press transmission shift selector pushbutton to desired range.
 - e. Release brake pedal and begin to move vehicle.
 - f. As required, select a specific forward gear using up or down arrow pushbuttons.

Driving Tips**WARNING**

BE ALERT for personnel in area while operating truck. Always check to ensure area is clear of personnel and obstructions before moving out. Failure to follow this warning may result in serious injury or death to personnel.

CAUTION

Governed speed is 2100 rpm. If engine is allowed to exceed governed speed, serious engine or transmission damage may result.

1. **Check gages and indicators frequently.** If gage or indicator shows an abnormal reading or warning light comes on, bring vehicle to a safe stop, shut down engine, and investigate cause.

OPERATING PROCEDURES - CONTINUED**Driving Tips - Continued****CAUTION**

Steering wheel should not be held at full steer for more than 10 seconds. This could result in overheating of oil, loss of oil from power steering reservoir, and pump gear damage.

2. **Avoid over steering.** Become familiar with steering characteristics of vehicle before attempting maneuvers in limited space.
3. **Drive efficiently and economically.**
 - a. **Driving at Highway Speed.** Recommended normal highway cruising range is 1800 - 1900 rpm. If operating on hilly terrain, in high winds, or in other conditions that make it impractical to operate without reserve power, operate vehicle in lower gear.
 - b. **Driving in City.** When slowing for posted speed zones, remain in Drive (D) position and reduce engine rpm.
 - c. **Driving Uphill (Under Load).** Proper use of gears shortens time on hills and minimize amount of shifting. As vehicle starts uphill, press accelerator pedal as required to maintain speed.

WARNING

DO NOT use engine brake if road surfaces are slippery. Use of engine brake on wet, icy, or snow-covered roads could result in loss of vehicle control. Failure to follow this warning could result in death or injury to personnel or damage to equipment.

- d. **Use Engine as a Braking Force.** The vehicle is equipped with an engine braking system that enables the engine to act as a brake. The engine brake should be used for descending grades and is most effective between 1750 - 2100 rpm.
 - (a) If maximum engine braking is required, move both engine brake selection switches up to engage six cylinders.
 - (b) If less than maximum engine braking is required, move left engine brake selection switch up and right engine brake selection switch down to engage two cylinders, or left engine brake selection switch down and right engine brake selection switch up to engage four cylinders.
- e. **Downhill Braking.**
 - (1) Select a gear that allows engine, with engine brake applied, to control vehicle speed with engine rpm at or below 2100 rpm without applying service brakes. As downgrade is approached, progressively select a gear that, when combined with engine brake, will allow you to maintain engine speed of 1750 - 2100 rpm.

OPERATING PROCEDURES - CONTINUED**Driving Tips - Continued**

- (2) As engine speed exceeds 2100 rpm, use one positive application of service brakes to slow engine speed to 1650 rpm, release engine brake, downshift one gear, and apply engine brake. Repeat this procedure until engine speed can be maintained at 1750 - 2100 rpm.

CAUTION

Excessive use of service brake to control downhill speed will result in loss of braking power due to heat build-up.

- (3) If you experience a total loss of braking due to heat build-up, apply engine brake (six cylinders), upshift as engine speed approaches 2100 rpm, and in Drive (D) position continue to apply engine brake and maintain directional control of vehicle.

CAUTION

Care must be exercised if tractor or trailer ABS light comes on while driving, possibly indicating an ABS malfunction. Although the regular/normal vehicle system is still fully operational, you should continue at a speed no greater than 40 mph (64 kph), until the mission is complete. When the mission is complete, report to Unit Maintenance to clear the ABS fault and restore full ABS capabilities.

- (4) The anti-lock brake system (ABS) will help in controlling wheel lockup and tire skidding during an emergency.

4. Engage interaxle lockout as required.**CAUTION**

DO NOT actuate interaxle lockout control valve while tires are spinning. DO NOT operate vehicle continuously with interaxle lockout control valve locked during extended good road conditions. Damage to axle gearing and excessive tire wear could result.

- a. If a difficult stretch of road approaches, stop and inspect it carefully before driving on it. Select transmission gear range that best suits road condition and place interaxle differential control valve lever to LOCK position.
- b. To lock interaxle, bring vehicle to a safe stop and move interaxle lockout control valve lever to LOCK position. Proceed over poor road conditions with caution.
- c. To unlock interaxle, place interaxle lockout control valve lever in UNLOCK position and remove foot from accelerator.

OPERATING PROCEDURES - CONTINUED

Driving

1. Perform initial adjustments, before use, and self-tests.
2. Start engine and allow truck to warm up.
3. Turn on lights, as necessary.
4. Ensure CWS self-tests.
5. With service brake applied, release parking brakes.
6. Select transmission gear.

WARNING

When coupled to a semitrailer, DO NOT exceed 35 mph (56 kph) on secondary (gravel) roads. Failure to follow this warning could result in injury.

7. Move truck gradually by depressing accelerator.

CAUTION

During long engine idling periods, engine coolant temperature will fall below normal operating range. The incomplete combustion of fuel in a cold engine will cause crankcase dilution, formation of lacquer or gummy deposits on valves, pistons, and rings, and rapid accumulation of engine sludge.

8. Avoid unnecessary engine idling.

CAUTION

Care must be exercised if tractor or trailer ABS light comes on while driving possibly indicating an ABS malfunction. Although the regular/normal vehicle system is still fully operational, you should continue in a safe manner and reduce speed to 40 mph (64 kph), until the mission is complete. When the mission is complete, report to Unit Maintenance to clear the ABS fault and restore full ABS capabilities.

NOTE

If, during operation, Low Air Pressure warning light comes on, stop vehicle, shut down engine, and investigate cause.

9. Check gages and indicators frequently.
10. Operate engine brakes as required.
11. Operate interaxle lockout, as required.
12. Stop vehicle by applying long even pressure to service brakes. Do not pump brakes.
13. After vehicle is at a complete stop, place transmission in Neutral (N) and pull parking brake control knob OUT. Ensure parking brake light comes on.

OPERATING PROCEDURES - CONTINUED

Driving - Continued

WARNING

If vehicle is left with engine running, vehicle can move suddenly causing serious injury or death to personnel or damage to equipment.

14. If you must leave vehicle with engine running, DO NOT leave vehicle without doing the following:
 - a. Ensure transmission is in Neutral (N).
 - b. Apply truck parking brake and semitrailer brakes (if coupled).
 - c. Chock wheels and take any other steps to keep vehicle from moving.

Shut Down Engine

CAUTION

Improper engine shutdown could damage turbocharger.

1. Run engine at idle for four to five minutes.
2. Turn all accessories off and place engine brake switches in OFF (down) position.
3. Move ignition switch to OFF position. Wait 10 seconds before placing master battery switch off.
4. Perform *After* operation PMCS (WP 0012 00).
5. Place master battery switch to OFF.

OPERATING PROCEDURES - CONTINUED**Operate Sliding Fifth Wheel/Couple to Semitrailer****CAUTION**

- The M915A4 is designed to be used with M871, M872 semitrailers and M967/M969 5000 gallon and M1062 7500 gallon fuel tankers only. Other semitrailers may cause equipment damage.
- Semitrailer wheels must be blocked and semitrailer brakes locked to prevent damage to tractor or semitrailer by uncontrolled sliding of fifth wheel.
- If towing M871 semitrailer, rear mud flaps must be removed and stowed in brackets provided. Failure to do so will cause equipment damage.
- Tractor trucks have the capability to turn greater than 90°. Care must be taken to avoid hitting semitrailer with tractor when turning more than 90°.
- Operator must use caution when cresting hills which cause the tractor truck to have a nose down angle greater than 4° with respect to towed semitrailer. Damage to vehicle or loss of control could occur.

NOTE

Start position for coupling is with fifth wheel jaws unlocked (open), fifth wheel in LOAD position, and fifth wheel slide control lever in LOCKED position.

1. Block semitrailer wheels.

WARNING

DO NOT use trailer handbrake as primary brake to keep tension on coupling system. This will cause undue tension on brakes and coupling which could result in injury to personnel or damage to equipment. Prevent problems with slack in fifth wheel by using good braking habits and adjusting coupling braking systems properly.

2. Ensure that fifth wheel ramps are level with, or are slightly below, the angle of the pickup ramps.

WARNING

Use caution when coupling to semitrailer. BE ALERT for personnel in area. Ensure that hands, arms, and body are clear of potential pinch points. Failure to follow this warning may result in injury to personnel.

CAUTION

Be careful not to run kingpin up fifth wheel ramps as this can damage kingpin and/or fifth wheel.

NOTE

- Truck and semitrailer must be aligned.
- Use a ground guide if one is available.

OPERATING PROCEDURES - CONTINUED

Operate Sliding Fifth Wheel/Couple to Semitrailer - Continued

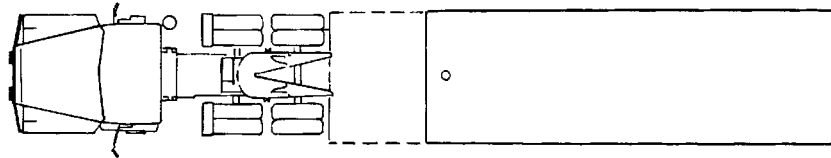

PROPER ALIGNMENT WITH SEMITRAILER

402-055

CAUTION

Fifth wheel teflon inserts and trailer kingpin plate must be clean and free of lubricant prior to coupling. Failure to follow this caution could cause damage.

3. Slowly back tractor under semitrailer kingpin plate. Stop when kingpin plate is touching guide ramps. Semitrailer kingpin should be centered as closely as possible in throat of fifth wheel.
4. Ensure that semitrailer is picked up with fifth wheel ramps. If kingpin comes in too high, it will not engage in fifth wheel correctly. Adjust semitrailer if needed.
5. Remove tether (2) from air hoses (3).
6. Remove air hoses (3) from bracket.

NOTE

One 12-volt light cable and one 24-volt light cable are stored in tool box.

7. Remove 12V or 24V intervehicular electrical cable from tool box.

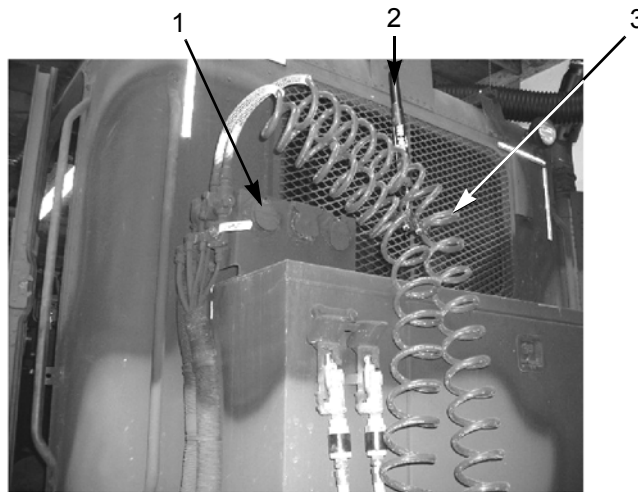

402-011

8. Connect air hoses (3) to trailer.
9. Connect intervehicular electrical cable to appropriate receptacle (1).

OPERATING PROCEDURES - CONTINUED

Operate Sliding Fifth Wheel/Couple to Semitrailer - Continued

10. Push trailer air supply control knob (8) IN, and set trailer control valve hand brake.
11. If trailer is ABS-equipped, connect ABS electrical cable.

CAUTION

Backing SLOWLY helps to prevent hitting too hard in coupling and damaging kingpin.

12. Back up slowly until fifth wheel locks firmly to kingpin.
13. Check kingpin connection and fifth wheel slide locks by pulling tractor gently forward against locked semitrailer brakes or blocked wheels. As resistance is felt, select transmission shift selector R (Reverse) pushbutton and gently back tractor to verify fifth wheel slide locks in both directions. When resistance is felt, select transmission shift selector N (Neutral) pushbutton and set parking brake.
14. Visually check that fifth wheel jaws close around kingpin.
15. Place fifth wheel slide control lever (4) to UNLOCKED position to disengage two slide locking plungers (5).

CAUTION

M967/M969 fuel tankers must be hauled with fifth wheel placed two notches rearward from HAUL position. Failure to follow this caution will cause equipment damage.

16. For M967/M969 fuel tankers, drive tractor backward and place fifth wheel two notches rearward from HAUL position.
17. For all other trailers, drive tractor backward to position fifth wheel in HAUL position.

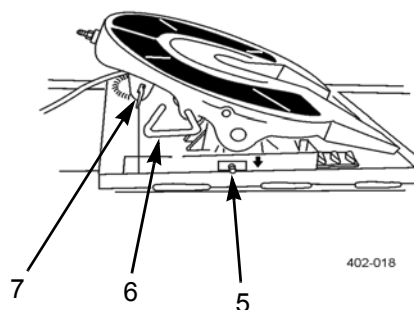
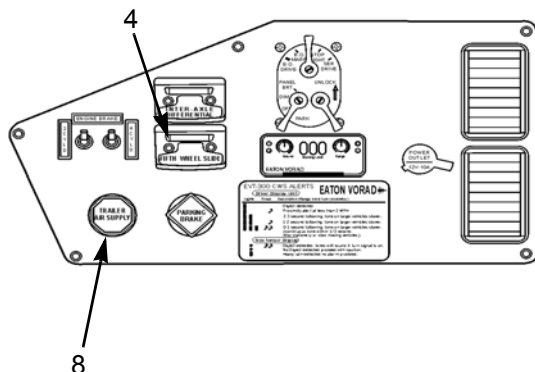

402-018

OPERATING PROCEDURES - CONTINUED

Operate Sliding Fifth Wheel/Couple to Semitrailer - Continued

CAUTION

DO NOT operate vehicle if slide locking plungers are not fully engaged and landing gear is not fully retracted. This could result in damage to tractor, semitrailer, and landing gear.

18. Place fifth wheel slide control lever (4) to LOCKED position to engage slide locking plungers. Ensure slide locking plungers (5) engage.
19. Verify that primary lock release handle (6) and secondary lock release handle (7) are in.
20. Check semitrailer lights.
21. Stow wheel blocks.
22. Lift and secure semitrailer landing gear and stow float pads.

OPERATING PROCEDURES - CONTINUED**Operate Sliding Fifth Wheel/Uncouple from Semitrailer****WARNING**

Use caution when uncoupling from semitrailer. BE ALERT for personnel in area. Ensure that hands, arms, and body are clear of potential pinch points. Failure to follow this warning may result in injury to personnel.

NOTE

- Truck and semitrailer must be aligned.
 - Use a ground guide if one is available.
1. Stop truck and semitrailer.
 2. Shift transmission into N (Neutral).
 3. Apply parking brake.
 4. Pull semitrailer air supply valve (1) OUT.
 5. Block semitrailer wheels.

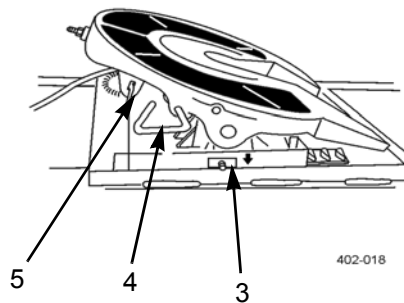
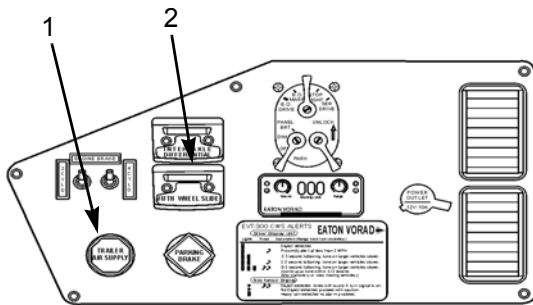
**CAUTION**

Lower landing gear until a small space can be seen between bottom of trailer and fifth wheel lube plates. Damage will occur if trailer edge drags across fifth wheel lube plates.

6. Place float pads under semitrailer landing gear and lower landing gear.
7. Set semitrailer hand brake control value and close semitrailer air supply control valve.

OPERATING PROCEDURES - CONTINUED

Operate Sliding Fifth Wheel/Uncouple from Semitrailer - Continued

CAUTION

To prevent damage to air hoses and electrical cables between trailer couplings, ensure air hose and cable ends are placed in storage bracket.

8. Disconnect and stow semitrailer air hoses and intervehicular cable.
9. Connect tether to air hoses.
10. If connected, disconnect and stow ABS electrical cable.
11. Place fifth wheel slide control lever (2) to UNLOCKED position.
12. Drive tractor forward to position fifth wheel to LOAD position.
13. Place fifth wheel slide control lever (2) to LOCKED position. Ensure slide locking plungers (3) engage.
14. Pull secondary lock release handle (5) out and lift to engage catch.
15. Pull primary lock release handle (4) out.
16. Release parking brake and slowly pull forward until semitrailer clears fifth wheel.
17. Stop and set parking brake.

OPERATING PROCEDURES - CONTINUED**Pintle Towing Procedures**

1. Block trailer wheels.
2. Remove cotter pin (2), engage latch (3), and lift lock (4) to open position.
3. Connect trailer to pintle hook (5).
4. Push lock (4) down ensuring latch (3) engages and install cotter pin (2).
5. Connect intervehicular electrical cable from trailer to tractor receptacle (6).
6. Connect air hoses from trailer to quick-disconnect couplings (1) at rear of vehicle.
7. Connect safety chains.

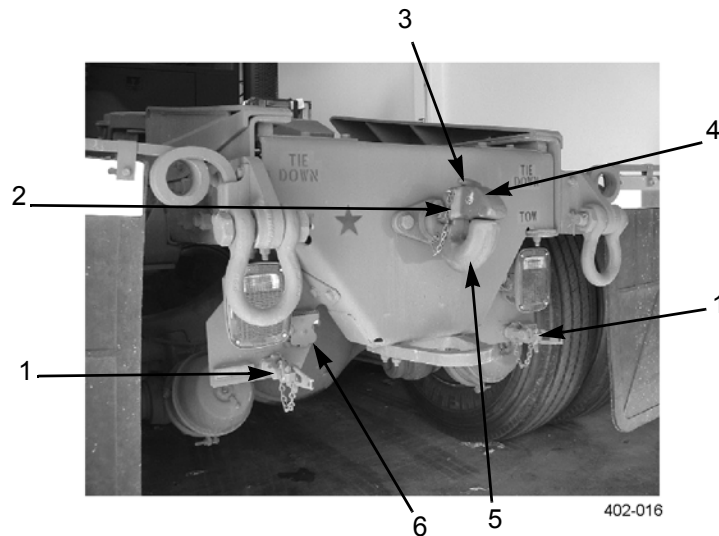
**WARNING**

Ensure air flow valve lever is in full horizontal position. Failure to follow this warning could result in loss of trailer or truck brakes.

8. Push in trailer air supply knob on instrument panel.
9. Remove wheel blocks from trailer.

OPERATING PROCEDURES - CONTINUED**Mud Flap Stowage****CAUTION**

If towing M871 or M872 semitrailer, or M967/M969/M1062 fuel tankers rear mud flaps must be removed and stowed in brackets. Failure to follow this caution may result in equipment damage.

1. Remove lock pin (1).
2. Pull up on mud flap (2) and remove. Tap spring upward with hammer as required.
3. Place mud flap (2) in stowage bracket (3) and insert lock pin (1).
4. When towing operations are complete, remove lock pin (1) and mud flap (2) from stowage bracket (3).
5. Position mud flap (2) on vehicle and install lock pin (1).

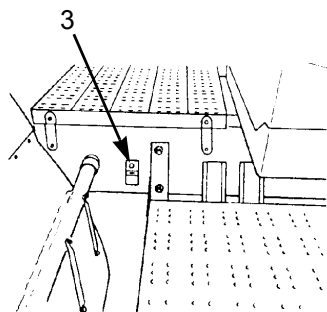
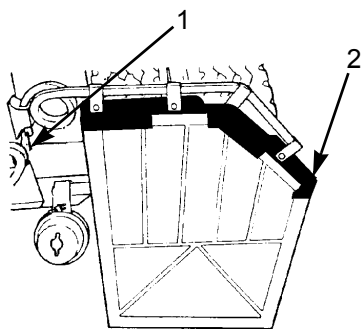

402-056

OPERATING PROCEDURES - CONTINUED

Operate Heater and Defroster

NOTE

Heater and defroster obtain heat from engine as it runs. If engine is not running, heat will not be available for these functions.

1. Start engine and bring truck to normal operating temperature.
2. Slide mode control lever (2) to desired position.
3. Slide temperature control lever (3) to desired temperature range.
4. Rotate fan switch (1) to adjust fan speed from slower to faster, as desired.
5. Press FRESH/RECIRC air button (4) to desired setting.

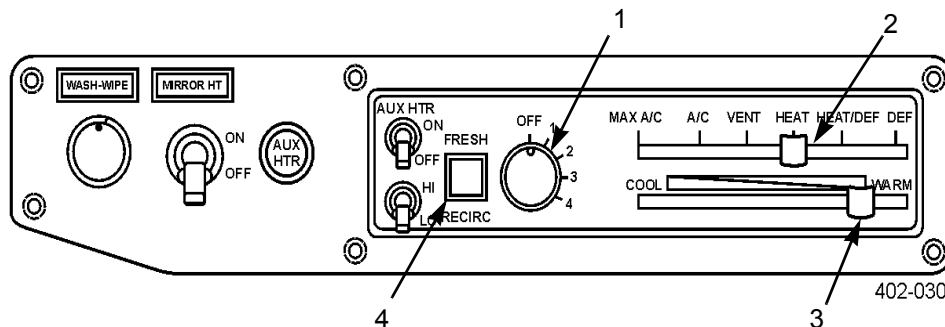

Operate Air Conditioner

1. If cab is hot inside, open windows and allow hot air to vent.
2. Move mode control lever (2) to VENT and turn fan switch (1) to OFF position.
3. Start engine.

NOTE

If outside air is dusty or smoky, mode control lever should be set to MAX A/C and windows and vent closed to prevent drawing dust or smoke into cab.

4. Move mode control lever (2) to A/C. With control at A/C, fresh air is drawn into cab. With control at MAX A/C, air inside cab is recirculated.

OPERATING PROCEDURES - CONTINUED**Operator Air Conditioner - Continued**

5. Move temperature control lever (3) to COOL.
6. Turn fan switch (1) to 4 (highest speed).
7. As soon as cool air is flowing from dashboard vents, close windows.
8. Adjust temperature control lever (3) and fan switch (1) as required.

Operate Portable Fire Extinguisher**WARNING**

Discharging large quantities of dry chemical fire extinguisher in the cab may result in temporary breathing difficulty during and immediately after the discharge event. If at all possible, discharge fire extinguisher from outside the cab. Avoid unnecessary contact during use and cleanup. Contact local medical personnel to determine necessary personal protective equipment to wear during cleanup.

NOTE

This is a type B and C fire extinguisher. Use on oil and electrical fires only.

1. Remove fire extinguisher (3) from bracket (5) next to shift tower.
2. Hold fire extinguisher (3) upright. Point nozzle (4) toward base of fire. Break seal and pull safety pin (1).
3. Squeeze lever (2), discharging chemical at base of fire. Use a side-to-side motion to spread chemical. After using fire extinguisher, notify Unit Maintenance.

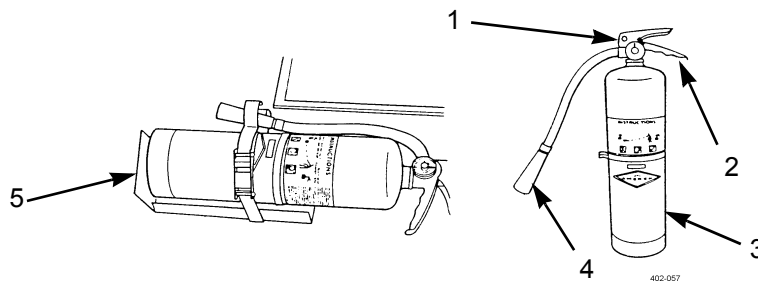

OPERATING PROCEDURES - CONTINUED**Operate Lights****NOTE**

If engine is not running, ignition switch must be in ON position for lights to operate.

1. **Operate Beacon Warning Light.**
 - a. Place ignition key in ACCESSORY or ON position and main light switch to STOP LIGHT or SER DRIVE position.
 - b. Move beacon light switch up to turn on beacon warning light (1). BCN LT indicator (4) should come on.
 - c. Move beacon light switch down. BCN LT indicator (4) should go off.
 - d. Place main light switch and ignition key in OFF position.
2. **Operate Work Lights.**
 - a. Connect work light plug into receptacle (3) on either side of cab or dash.
 - b. Place ignition key in ACCESSORY position and main light switch in STOP LIGHT or SER DRIVE position to apply power to receptacle.
 - c. Position ignition key in OFF position and disconnect work light plug from receptacle (3).
3. **Operate Utility Lights.**
 - a. Place ignition key in ACCESSORY or ON position and main light switch in STOP LIGHT or SER DRIVE position.
 - b. Move utility light switch up to turn utility lights (2) on. UTLY light indicator (5) should come on.
 - c. Move utility light switch down. UTLY light indicator (5) should go off.
 - d. Place ignition key in OFF position.

OPERATING PROCEDURES - CONTINUED

Operate Lights - Continued

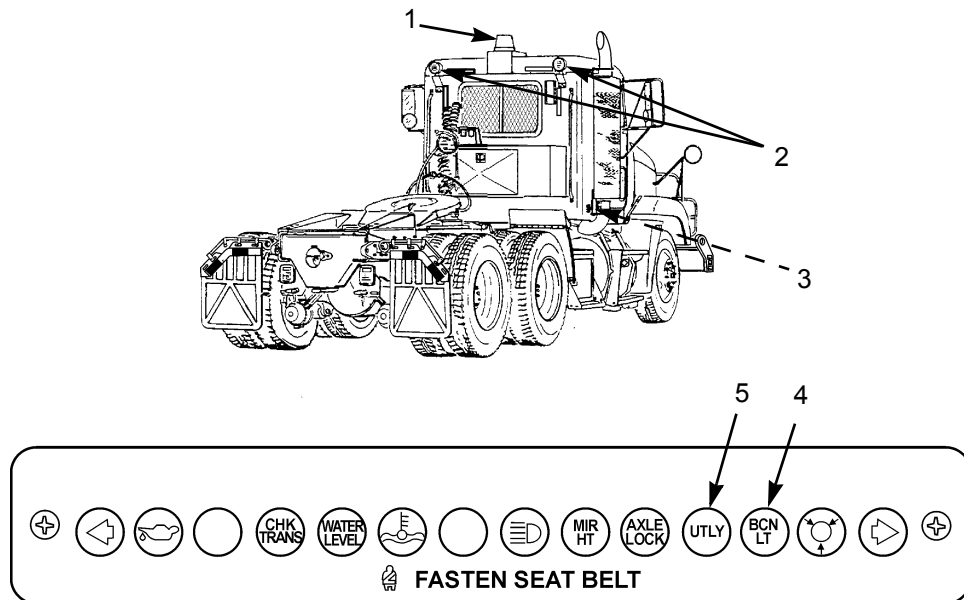

402-019

4. **Operate Interior Lights.**

NOTE

Interior lights DO NOT come on when cab door is opened.

- a. Turn main light switch to STOP LIGHT or SER DRIVE position.

OPERATING PROCEDURES - CONTINUED

Operate Lights - Continued

- b. Slide thumb switch (7) down on driver's side and up on passenger side to turn on maplight (6) only.
- c. Slide thumb switch (7) up on driver's side and down on passenger side to turn on domelight (8) and map light (6).
- d. Place main light switch in OFF position.

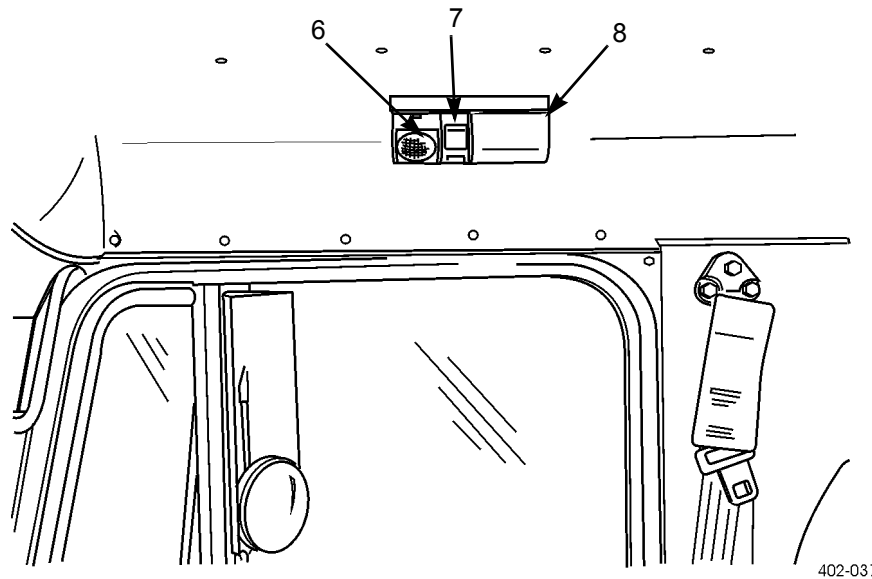

402-037

Rifle Mounting Kit

Two rifle mounting kits (1) are located between seats on cab wall.

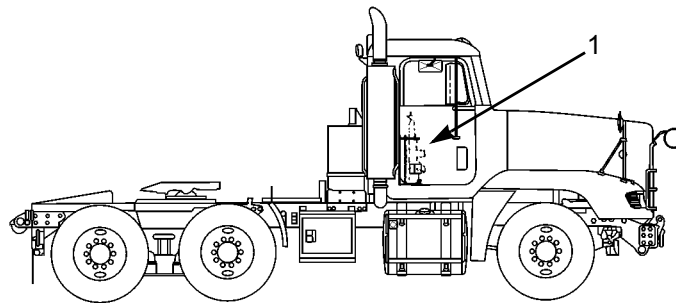

OPERATING PROCEDURES - CONTINUED**Preparation For Transport****WARNING**

- Lifting cables, chains, hooks, and slings used for lifting truck must be in good condition and of suitable capacity. Failure to follow this warning may result in injury or death to personnel and damage to equipment.
- Improper use of lifting equipment and improper attachment of cables to vehicle can result in serious personnel injury and equipment damage. Observe all standard rules of safety.
- Front extendable bumper is for overhead sling use only. It is not intended to be used to tow or extract a mired vehicle. DO NOT extend the bumper more than one adjustment hole. ALWAYS have both pins engaging the bumper and bumper extension on each side. Failure to follow this warning could result in injury to personnel and damage to equipment.

CAUTION

DO NOT attempt to overhead lift vehicle without extending front bumper one adjustment hole. Failure to follow this caution will result in damage to cab.

NOTE

Both left and right side bumper extensions are adjusted in the same manner. Right side is shown.

1. Remove two retaining pins (1), and straight pins (2) from front bumper (3).
2. Position bumper extension (5) in front bumper (3) so straight pins (2) will engage two inside adjustment holes (4) on bumper extension.
3. Install two straight pins (2), and two retaining pins (1) in front bumper (3).
4. To lift vehicle, attach suitable lifting device to lifting shackles. Lift vehicle slowly and have observers watch for any signs of cable failure, unusual load shifts, and obstructions.
5. During transport, secure vehicle by attaching cables to tiedown points.

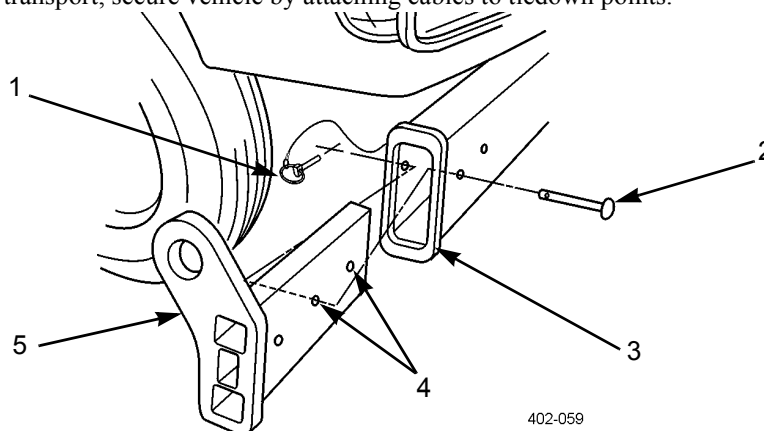

402-059

OPERATING PROCEDURES - CONTINUED

Operate Tilttable Hood

1. **Open Tilttable Hood.**

- a. Unlock hood retaining strap (3) from hood locking bracket (4).
- b. Repeat step (1) for opposite side.

CAUTION

DO NOT attempt to open hood from side. ALWAYS use hand slot located at top-front center of hood to rotate hood to open position. Failure to follow this caution could result in equipment damage.

- c. Grasp hand slot (1) at top-front center of hood (2) and rotate hood to open position.

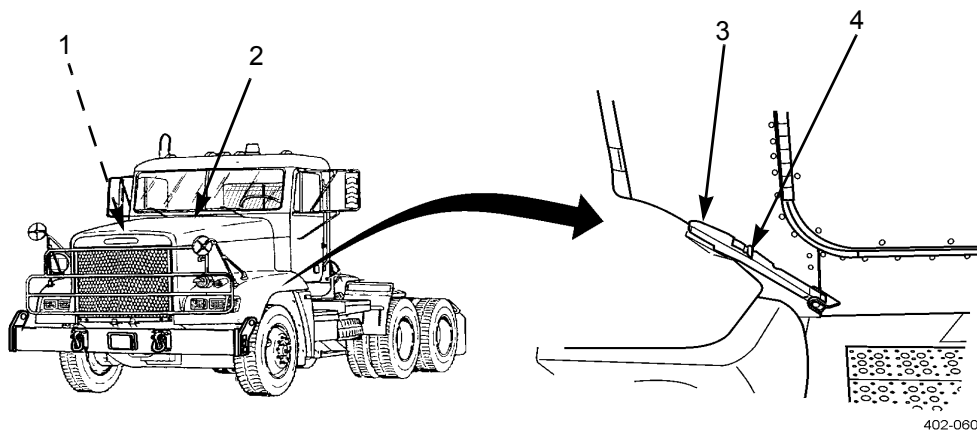

402-080

WARNING

ALWAYS install hood prop after opening hood. Failure to follow this warning could result in severe injury to personnel.

- d. Remove hood prop rod (5) from bracket.
- e. Rotate and install hood prop rod (5) end in slot in bracket (6).

OPERATING PROCEDURES - CONTINUED

Operate Tilttable Hood - Continued

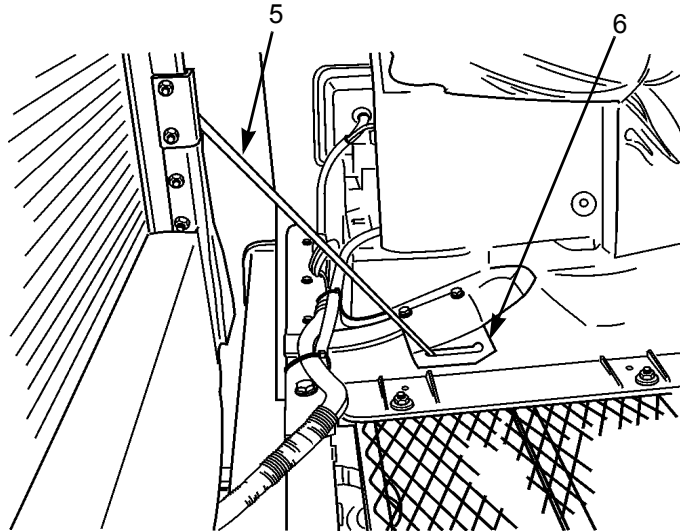

402-008

2. **Close Tilttable Hood.**
 - a. Remove hood prop rod (5) end from bracket (6).
 - b. Rotate hood prop rod (5) and secure in bracket.
 - c. Grasp hand hold (1) at top front center of hood (2) and lower hood to closed position.
 - d. Lock retaining strap (3) on hood locking bracket (4).

END OF WORK PACKAGE

GENERAL**WARNING**

These vehicles have been designed to operate safely and efficiently within the limits specified in this TM. Operation beyond these limits is prohibited in accordance with AR 70-1 without written approval from: Commander, U.S. Army Tank-automotive and Armaments Command, ATTN:AMSTA-LC-AF-IM, Warren, MI 48397-5000.

- a. This work package contains instructions for safely operating the M915A4 under unusual conditions. In addition to normal preventive maintenance, special care must be taken to keep truck operational in extreme temperatures and other environmental conditions.
- b. Refer to FM 21-300 and FM 21-305 for additional information.

SLAVE START TRUCK**WARNING**

- When slave starting truck, use NATO slave cable that DOES NOT have loose or missing insulation.
- DO NOT proceed if suitable cable is not available.
- DO NOT use civilian-type jumper cables.
- Failure to follow this warning could result in injury to personnel.

CAUTION

- DO NOT operate starter motor for more than 30 seconds at a time. After 30 seconds, allow starter motor to cool for at least two minutes before attempting to start engine again. Excessive heating of starter motor may result in damage or early starter failure.
- Under no circumstances can the truck be started by being towed or pushed. Failure to follow this caution will cause damage to transmission.
- Ensure there is no contact between vehicles when slave starting. Failure to follow this caution could result in equipment damage.

SLAVE START TRUCK - CONTINUED**NOTE**

If vehicle other than another M915A4 is used to slave start truck, refer to Operator's Manual for that vehicle for any special slave starting procedures.

1. Connect NATO slave cable to receptacle (1) on "dead" vehicle.
2. Connect other end of NATO slave cable to receptacle on "live" vehicle.
3. Place master battery switch on "dead" vehicle to ON.
4. Start engine of "live" vehicle and run at 1000 rpm until voltmeter on "dead" vehicle is in green band. Stop engine and remove NATO slave cable from receptacle.
5. Start engine of "dead" vehicle (WP 0005 00). If engine will not start, Notify Unit Maintenance.

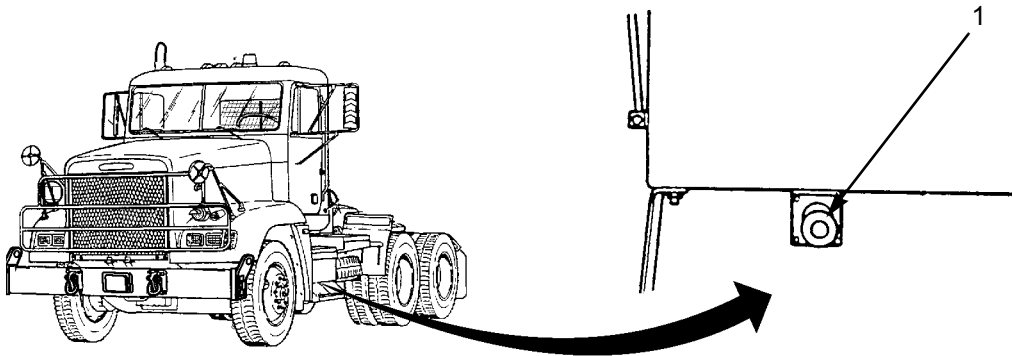

402-061

TOW TRUCK

1. **General.**
 - a. Notify Unit Maintenance to send recovery vehicle and tools required to disconnect propeller shafts.
 - b. Refer to FM 21-305 for general guidelines on vehicle recovery and use of warning kits and signals. Refer to FM 20-22 for additional information.

CAUTION

Propeller shafts must be disconnected and interaxle lockout control valve lever must be in UNLOCK position before towing truck with all wheels on the ground. Failure to follow this caution may result in transmission damage.

TOW TRUCK - CONTINUED

- c. When towing truck with front axle and rear tandem on ground, ensure that interaxle lockout control valve lever is in UNLOCK position. Ensure that universal joint on rear of propeller shaft (at the input to the forward-rear axle) is disconnected and tied up to vehicle undercarriage.
- d. When front axle of truck being towed is lifted off the ground, disconnect universal joint on propeller lever (at the input to the forward-rear axle) and tie it up to vehicle undercarriage.
- e. When rear tandem axles of truck being towed are lifted off ground, ensure interaxle lockout control valve lever is in UNLOCK position.

2. Towing Procedures.**WARNING**

Brakes will be released when air is applied to a disabled vehicle. DO NOT connect air lines to a disabled vehicle without first blocking wheels and connecting tow bar between vehicles. Failure to follow this warning could result in death or injury to personnel and damage to equipment.

NOTE

Towing vehicle speed should not exceed 45 mph (72 kph) on primary roads and 15 mph (24 kph) on secondary roads. For cross-country towing, all tires of disabled truck should be on ground.

- a. Install medium duty tow bar at towing vehicle pintle and disabled truck towing eyes. Ensure tow bar is long enough to allow complete turning radius.
- b. Connect air supply hoses between disabled truck and towing vehicle.
- c. Release parking brakes and turn appropriate lights on.

CAGE AND UNCAGE BRAKES

- 1. **Cage Brakes.** In the event of an air pressure loss, spring brakes on the tandem rear axles will apply the brakes. If the vehicle must be towed and there is not enough air system pressure to compress the power spring in the spring brake chambers to release the brakes, compress them manually. Each vehicle has four spring brakes.

CAGE AND UNCAGE BRAKES - CONTINUED**WARNING**

- Brake chamber contains spring under great pressure. To prevent personnel injury, never work directly behind chamber. If caging bolt will not engage properly, spring may be broken.
- Do not remove clamp ring around spring brake chamber. It is under tension and can cause personnel injury if released.
- When spring brakes are applied, vehicle will stop quickly which could result in injury to personnel. Also, vehicle cannot be driven again until malfunction is repaired and enough air is present for operation of service brakes.

WARNING

When caging brakes, block wheels to keep truck from moving when brakes are released. Failure to follow this warning may result in death or injury to personnel or damage to equipment.

- a. Block wheels.
 - b. Remove cap (3) from spring chamber (6).
 - c. Remove nut (4), washer (5), and release stud (2) from stowage pocket (1).
 - d. Insert cross-pin end of release stud (2) into opening where cap (3) was removed.
 - e. To engage cross-pin, rotate release stud (2) until cross-pin end goes into slot inside of spring chamber (6). Turn release stud clockwise $\frac{1}{4}$ turn; cross-pin is now engaged.
 - f. Install washer (5) and nut (4) on release stud (2).
 - g. Tighten nut (4) until approximately 3 in. of release stud (2) shows above nut. Spring brake is fully released.
2. **Uncage Brakes.**
- a. Block wheels.
 - b. Remove nut (4) and washer (5) from release stud (2).
 - c. Turn release stud (2) counterclockwise $\frac{1}{4}$ turn and remove release stud from spring chamber (6).
 - d. Insert release stud (2) into stowage pocket (1) and install washer (5) and nut (4) on release stud.
 - e. Install cap (3) in spring chamber (6).

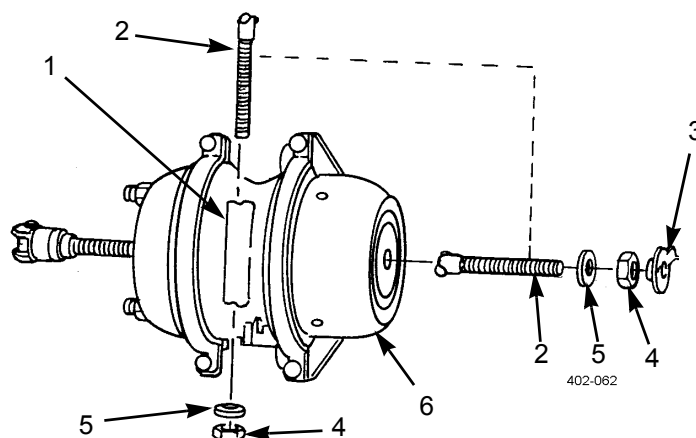
CAGE AND UNCAGE BRAKES - CONTINUED**OPERATE IN EXTREME COLD**1. **General.**

- a. Extreme cold causes many problems:
 - (1) Lubricants thicken or congeal.
 - (2) Batteries may freeze or lose their electrical efficiency.
 - (3) Fuel may not readily atomize for combustion.
 - (4) Various materials will become hard, brittle, and easily damaged.
 - (5) The cooling system requires adequate protection from extreme cold.
 - (6) Fuels, lubricants, and antifreeze compounds require special storage, handling, and use.
- b. Refer to FM 9-207 for additional information.
- c. Arctic Heater Kit. All vehicles assigned to arctic regions are equipped with an auxiliary arctic heater kit which protects vehicle systems from freeze damage, enables easier starting by providing engine block preheating, and boosts cab heat output. Refer to subparagraph b for operation of arctic heater.
- d. Starting Out.
 - (1) Be careful when you first start your vehicle. Use cold weather starting procedure and allow engine time to reach operating temperature range of 120-140°F (48-59°C). Be alert that tires may be frozen to ground.

OPERATE IN EXTREME COLD - CONTINUED

- (2) Start driving very slowly for about 100 yards (91.4 m). Be alert for signs that tires may have flat spots or that one or more brake shoes may be frozen and require preheating. Notify Unit Maintenance as required.
 - e. Parking.
 - (1) If vehicle will be parked for a short period, park in a sheltered area out of wind. If shelter is not available, park vehicle so it does not face into the wind.
 - (2) If vehicle will be parked for a long shutdown period, try to park on high ground and use planks or brush to make a raised and relatively dry surface. Keep tires out of snow, water, ice, and mud, if possible.
 - (3) Clean snow, ice, and mud from vehicle as soon as possible after shutdown.
 - (4) If vehicle will be parked for a long period of time, have Unit Maintenance remove and store batteries. Fill fuel tank to guard against condensation and drain any accumulated water from air reservoirs and fuel filters.
 - (5) Ensure tires are properly inflated.
2. **Operate Arctic Heater to Preheat Engine (If Equipped).**

NOTE

- Arctic heater is used to provide engine preheating for engine startup in extreme cold. It is also used to provide personnel heat. When heater is required to preheat engine coolant and engine block before startup, it should be turned on 1/2-1 hour before engine is started.
 - Auxiliary heater (AUX HTR) indicator light illuminates only when burner is lit. Indicator light turns on and off automatically.
 - During auxiliary heater operation, watch battery indicator. If necessary, start engine to charge batteries.
- a. Place master battery switch to ON.
 - b. Turn all electrical equipment in cab OFF (i.e., heated mirrors, defroster blower, personnel heater blower, etc.).
 - c. Push auxiliary heater coolant flow control knob IN (located on the radio support bracket).
 - d. Place heater mode control lever (3) to HEAT.
 - e. Turn ignition switch to the accessory position (counterclockwise).
3. **Operate Arctic Heater to Heat Cab (If Equipped).**

OPERATE IN EXTREME COLD - CONTINUED**NOTE**

- Arctic heater is used to provide engine preheating for engine startup in extreme cold. It is also used to provide personnel heat. When heater is required to preheat engine coolant and engine block before startup, it should be turned on 1/2-1 hour before engine is started.
 - Auxiliary heater (AUX HTR) indicator light illuminates only when burner is lit. Indicator light turns on and off automatically.
 - During auxiliary heater operation, watch battery indicator. If necessary, start engine to charge batteries.
- a. Place master battery switch to ON.
 - b. Turn all electrical equipment in cab OFF (i.e., heated mirrors, defroster blower, personnel heater blower, etc.).
 - c. Push auxiliary heater coolant flow control knob OUT (located on the radio support bracket).
 - d. Place heater mode control lever (3) to HEAT.
 - e. Turn ignition switch to the accessory position (counterclockwise).
 - f. Place AUX HTR switch (2) in ON position. Green light in switch will illuminate. AUX HTR light (1) will light when combustion starts after approximately 50 seconds.

NOTE

If HI-LO switch is set to HI position, heater will automatically switch to low heat when temperature of coolant at heater inlet reaches 176°F (80°C). LO position is suitable when heater operates over an extended period.

- g. Place HI-LO switch (4) to desired setting.
- h. To turn auxiliary heater off, place AUX HTR switch (2) to OFF position. Heater burner will stop and AUX HTR light will go out within a few minutes. Blower will continue to run for approximately 90 seconds.

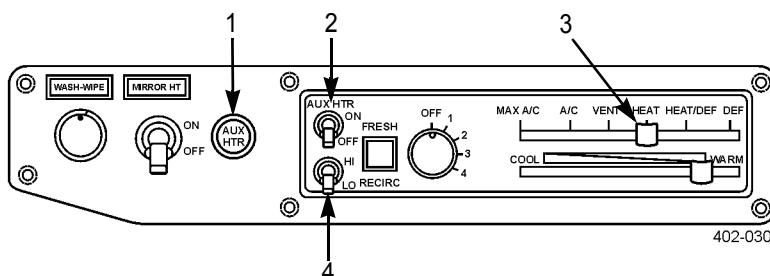

OPERATE IN EXTREME HEAT

1. **General.** During very hot weather, driving procedures may require altering to prevent vehicle overheating. Avoid continuous high speeds, long, hard pulls, and continuous operation in soft terrain.
2. **Driving Vehicle.**
 - a. Check water temperature gage and stop if temperature is unusually high. Allow vehicle to cool down. Check cooling system, air cleaner, air cleaner restriction indicator, engine oil level, and radiator fins frequently. Perform necessary services and notify Unit Maintenance of any unusual gage readings or problems.
 - b. Notify Unit Maintenance to shorten differential oil change interval.
3. **Parking Vehicle.**
 - a. Park vehicle under cover, if possible. If shelter is not available, cover vehicle with tarpaulins. If there aren't enough tarps to cover entire vehicle, arrange tarps around engine compartment and over radiator to keep sand and dust out. Cover window glass to protect against sand blasting.
 - b. Ensure all tires are inflated to proper pressure.
 - c. Check frequently for rust and fungus growth. Clean and lubricate vehicle to help prevent deterioration.

OPERATE IN MUD OR SOFT SURFACES**NOTE**

- M915A4 is equipped with No Spin® automatic locking positive traction differential on the forward-rear axle. The No Spin® differential eliminates individual wheel spinout for better traction.
 - When locking system is engaged, driving axles receive equal torque.
1. Before entering mud or other soft surfaces, check conditions and select appropriate transmission gear range. Place interaxle lockout control valve lever in LOCK position. Enter soft area at a medium speed for gear range selected.
 2. Maintain steady pressure on accelerator pedal to keep vehicle rolling until solid ground is reached. Do not accelerate to point where wheels spin. Do not stop, if possible.
 3. If vehicle gets stuck, try to pull out slowly in a low gear. Boards, brush, or similar materials may be placed under tires to provide traction.
 4. When vehicle reaches hard surface, place interaxle lockout control valve lever in UNLOCK position.
 5. Notify Unit Maintenance to clean and inspect propeller shafts for proper lubrication.

FORDING

1. **General.**
 - a. Maximum fording depth is 20 in. (50.8 cm).
 - b. Ford to maximum depth for short periods and short distances only. Vehicles can ford to maximum depth for five minutes without requiring maintenance to continue operation.
2. **Before Fording.**
 - a. Check bottom surface of water to ensure it is hard enough to be forded without exceeding maximum fording depth.
 - b. Ensure that engine is operating properly.
 - c. Lubricate unpainted surfaces to guard against rust and deterioration.
 - d. Place interaxle lockout control valve lever in LOCK position.
3. **During Fording.**
 - a. Place transmission in a low gear and enter water slowly.
 - b. Ford at speeds of 3-4 mph (5-6 kph).
4. **After Fording.**
 - a. When vehicle emerges from water, apply brakes a few times to dry brake linings. Ensure that brakes are working properly before driving at normal speeds.
 - b. Place interaxle lockout control valve lever in UNLOCK position.
 - c. Allow engine to run for awhile to drive out any accumulated water.
 - d. Drain or dry any area where water has accumulated.
 - e. Check all fluids for signs of contamination and for proper levels (WP 0017 00).
 - f. If vehicle has been operated in salt water, rinse undercarriage immediately. Allow exterior to dry and check for evidence of salt accumulation. Use a clean, damp cloth to immediately remove all salt accumulation.
 - g. Notify Unit Maintenance that after-fording lubrication is required.

OPERATE IN SANDY OR DUSTY CONDITIONS**NOTE**

- M915A4 is equipped with No Spin® automatic locking positive traction differential on the forward-rear axle. The No Spin® differential eliminates individual wheel spinout for better traction.
 - When locking system is engaged, driving axles receive equal torque.
1. Maintain steady, even movement with transmission in lower gears and interaxle lockout control valve lever in LOCK position. Try to keep vehicle rolling without straining engine and powertrain.

OPERATE IN SANDY OR DUSTY CONDITIONS - CONTINUED

2. If vehicle gets stuck, reduce tire pressure to gain additional traction. Reduce pressure in front tires to 50 psi (344 kPa) and pressure in rear tires to 45 psi (310 kPa). Inflate tires to normal pressures once vehicle is freed.
3. If vehicle bogs down, after tire pressure has been reduced, place boards, brush, canvas, or similar materials under and in front of tires after shoveling a clear path ahead of each tire. This should improve traction.
4. If these efforts fail and it becomes evident that vehicle will not free itself, have another vehicle tow stuck vehicle.
5. Whenever operating in sandy or dusty areas, you should:
 - a. Ensure each tire has a valve cap.
 - b. Check engine and transmission temperature and engine oil pressure frequently.
 - c. If vehicle overheats, stop and find out why. Service or notify Unit Maintenance, as necessary.
 - d. Ensure engine oil filler tube and transmission fluid filler tube are cleaned before dipsticks are removed to check fluid levels. Clean accumulations of sand and dirt from around any fluid filler locations before checking or adding fluids.
 - e. Clean spouts of fuel containers and areas around filler caps on fuel tanks before adding fuel. Under extremely sandy or dusty conditions, filter fuel when filling tanks.
 - f. Cover window glass to protect against sand blasting.
 - g. Notify Unit Maintenance to clean, inspect, and lubricate propeller shafts more frequently.

OPERATE IN WOODS OR ON ROCKY TERRAIN**CAUTION**

Original equipment tires will heat up on primary road surfaces and become more susceptible to damage when entering secondary road/gravel/rocky surfaces. If mission requires driving on both primary and secondary road surfaces, off-road tires should be installed. Ensure to maintain tire set integrity by not mixing original equipment tires with off-road tires. Failure to follow this caution could cause equipment damage.

OPERATE IN WOODS OR ON ROCKY TERRAIN-CONTINUED**NOTE**

- M915A4 is equipped with No Spin® automatic locking positive traction differential on the forward-rear axle. The No Spin® differential eliminates individual wheel spinout for better traction.
 - When locking system is engaged, driving axles receive equal torque.
1. Ensure vehicle can clear any obstructions and try to avoid low hanging tree limbs which might cause damage.
 2. Ensure spare wheel and tire assembly is available.

OPERATE ON SNOW OR ICE**CAUTION**

Original equipment tires will heat up on primary road surfaces and become more susceptible to damage when entering secondary road/gravel/rocky surfaces. If mission requires driving on both primary and secondary road surfaces, off-road tires should be installed. Ensure to maintain tire set integrity by not mixing original equipment tires with off-road tires. Failure to follow this caution could cause equipment damage.

NOTE

- M915A4 is equipped with No Spin® automatic locking positive traction differential on the forward-rear axle. The No Spin® differential eliminates individual wheel spinout for better traction.
 - When locking system is engaged, driving axles receive equal torque.
1. **General.**
 - a. **Driving.**
 - (1) Accelerate slowly to avoid spinning tires.
 - (2) Drive at slower speeds.
 - (3) Give signals sooner.
 - (4) Apply brakes sooner to give early warning of intention to stop. This will also help to avoid skidding.
 - (5) Maintain double the normal distance from the vehicle ahead.
 - (6) Keep windshields, windows, mirrors, headlights, stoplights, body lights, and CWS antenna and side sensor clean and free of snow and ice. Use defroster to help keep glass free of snow and ice.
 - (7) Descend moderate grades in gear normally used for ascending same grade. On steep or very slippery grades, place interaxle lockout control valve lever in LOCK position and use at least one gear lower.

OPERATE ON SNOW OR ICE - CONTINUED

- (8) After driving through slush or water, drive slowly and test brakes. Keep driving slowly, maintaining moderate pressure on service brake pedal to create a slight drag. When brakes are dry and operating properly, resume normal speed.
- (9) If a difficult stretch of road approaches, stop and inspect it carefully before driving on it. Select transmission gear range that best suits road condition and place interaxle lockout control valve lever in LOCK position.

NOTE

Shifts from Neutral (N) to Drive (D) or to Reverse (R) cannot occur if engine speed is above idle. Reduce engine speed to idle and shift again.

- (10) If vehicle becomes stuck or tires start spinning, it may be possible to rock vehicle out. Lock interaxle lockout and shift transmission to D (Drive). Apply light, steady throttle (never full throttle). When vehicle has moved as far as it will go, apply service brakes and allow engine to return to idle speed. Shift transmission to R (Reverse). Again, apply light, steady throttle and allow vehicle to move rearward as far as it will go. Apply service brakes and allow engine to return to idle speed. This procedure can be continued as long as each directional shift moves vehicle a greater distance. If not, vehicle should be towed from its position.
- b. **Stopping.**
- (1) Ease up on accelerator, leaving vehicle in gear.
 - (2) Apply service brakes lightly and evenly. DO NOT pump service brake pedal.

WARNING

Do not use engine brake if road surfaces are slippery. Using engine brake on wet, icy, or snow covered roads could result of loss of vehicle control. Failure to follow this warning could result in death or injury to personnel or damage to equipment.

- (3) Always avoid sudden braking and use of engine brake on slick roads.

CAUTION

Care must be exercised if tractor or trailer ABS light comes on while driving, possibly indicating an ABS malfunction. Although the regular/normal vehicle system is still fully operational, continue in a safe manner and reduce speed to 40 mph (64 kph) until mission is complete. When mission is complete, notify Unit Maintenance to troubleshoot ABS fault and restore full ABS capabilities.

OPERATE ON SNOW OR ICE - CONTINUED

- (4) During emergency or reduced traction stops, press brake pedal fully until vehicle comes to a safe stop. DO NOT PUMP brake pedal. With brake pedal fully depressed, ABS will control all wheels to provide steering control and a reduced braking distance.
- c. **Parking.** If parking on icy, slushy, wet, or muddy surfaces, place boards, brush, or other materials that will provide traction underneath tires. This will guard against tires freezing to the ground or becoming pocketed in ice, and will provide some traction when vehicle is started and moving again.
2. **Install Tire Chains.**
- Lay out chains flat on ground alongside tire to be mounted. Untangle any cross chains.
 - Open all cams (4) (to longest spacing).
 - Pick up rear side chains (1) (no cams) and place over top of tire.
 - Tuck last crossmember (2) against bottom of tire with loose side chain (3) sticking out away from tire.
 - Roll vehicle in direction of last crossmember (2) (approximately 1/4 tire revolution).

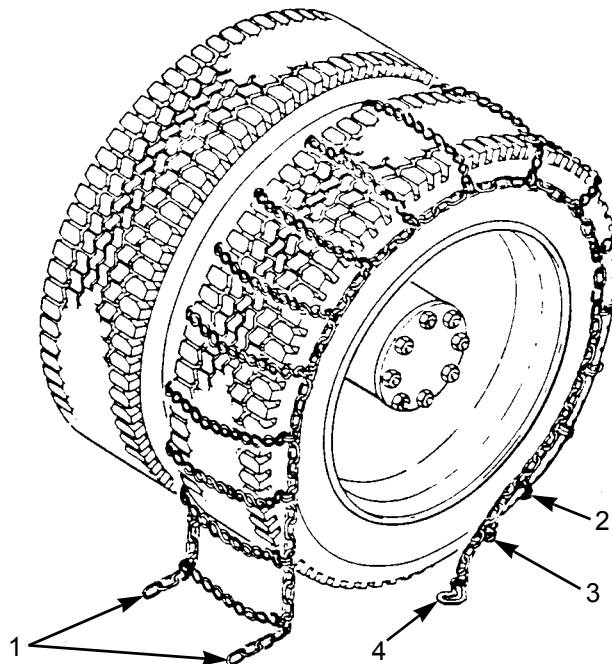

402-063

OPERATE ON SNOW OR ICE - CONTINUED

- f. Pull inside side chain (5) snug and hook into appropriate link to hold snug.
- g. Pull outside side chain (6) snug and hook.

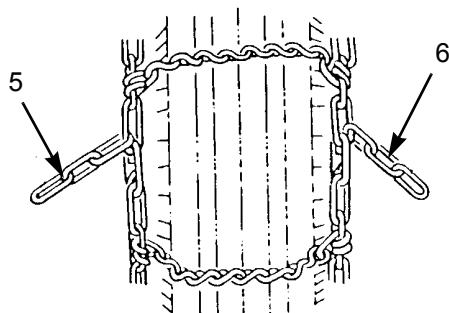

402-064

NOTE

Hooks must be even. Same number of loose links must appear on each side of chain. If not even, loosen outside hook and rehook both inside and outside hooks until they are even.

- h. Close cams (4) by inserting key (7) in slot and rotate 180 degrees clockwise. Start with cam closest to side chain hook.

NOTE

All four cams should not have to be locked for chain to be tight.

- i. If additional tightening is required, tighten cam on opposite side of tire. Continue tightening cams as required.
- j. If all four cams are tight and chain is not tight, loosen all four cams and resnug side chain at fastener hook until no more than three cams require adjustment.
- k. Drive approximately 1/2 mile and readjust chains as required.

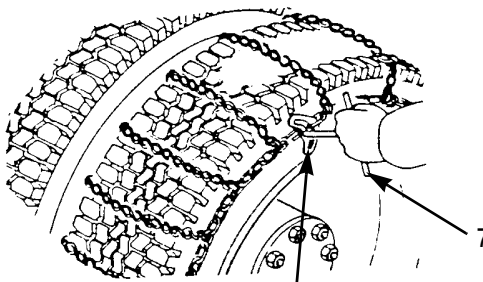

4 402-065

END OF WORK PACKAGE

SCOPE

- a. This appendix shows the location for stowage of equipment and material required to be carried on the M915A4.
- b. This appendix also includes illustrations showing the location of all decals, data plates, and stencils.

DECALS AND PLATES

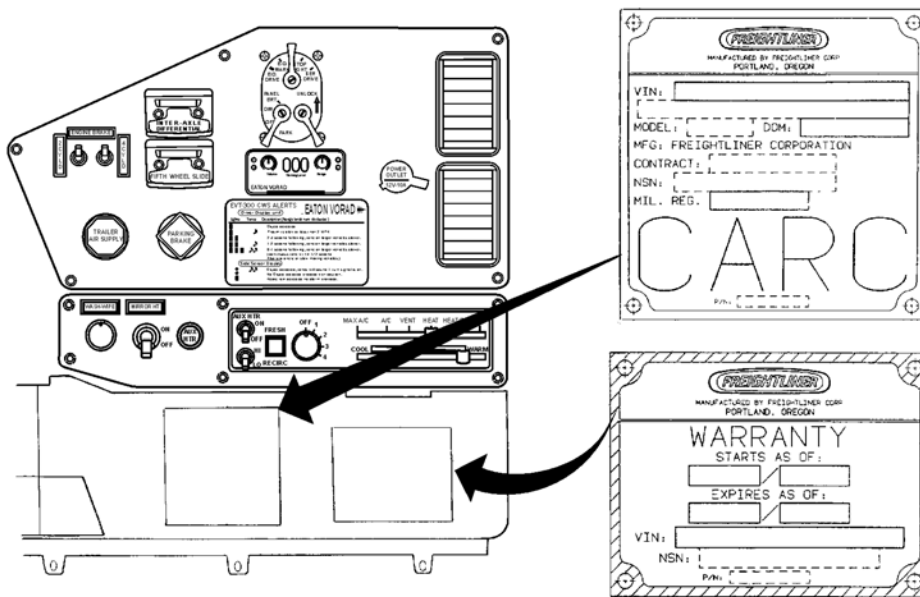

402-077

**STORAGE AND DECAL, DATA PLATE,
AND STENCIL GUIDE - CONTINUED**

0007 00

DECALS AND PLATES - CONTINUED



MANUFACTURED BY FREIGHTLINER CORP.
PORTLAND, OREGON

NOTE: HORIZONTALLY,
TRUCK CENTER OF GRAVITY
(CG) LIES ALONG TRUCK
CENTER-LINE.

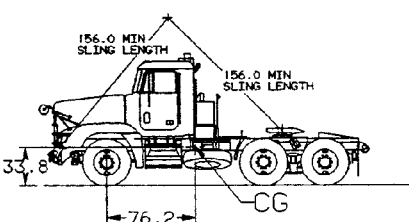

SHIPPING DATA-M915A4

OVER-ALL LENGTH: 276.00 IN.	SHIPPING TONNAGE: 10 TONS
OVER-ALL HEIGHT: 118.00 IN.	FRONT AXLE WEIGHT: 9,700 LBS.
OVER-ALL WIDTH: 100.00 IN.	FRONT-REAR AXLE WEIGHT: 4,310 LBS.
SHIPPING VOLUME: 1,847.0 CU.FT.	BACK-REAR AXLE WEIGHT: 4,310 LBS.
SHIPPING WEIGHT: 18,320 LBS.	P/N: 24-00848-000

CAUTION

SLAVE START PROCEDURES

- 1- CONNECT NATO SLAVE CABLE TO RECEPTACLE ON "DEAD" VEHICLE.
- 2- CONNECT OTHER END OF NATO SLAVE CABLE TO RECEPTACLE ON "LIVE" VEHICLE.
- 3- PLACE MASTER BATTERY SWITCH TO "ON".
- 4- START ENGINE OF "LIVE" VEHICLE AND RUN AT 1000 RPM UNTIL VOLTMETER OF "DEAD" VEHICLE IS IN GREEN BAND. STOP ENGINE. REMOVE NATO SLAVE CABLE FROM RECEPTACLE.

NOTE

ENSURE VOLTMETER OF "DEAD" VEHICLE IS IN GREEN BAND BEFORE PUSHING STARTER BUTTON.

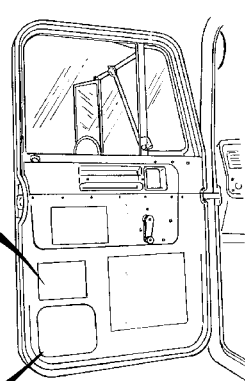

402-079

**STOWAGE AND DECAL, DATA PLATE,
AND STENCIL GUIDE - CONTINUED**

0007 00

DECALS AND PLATES - CONTINUED

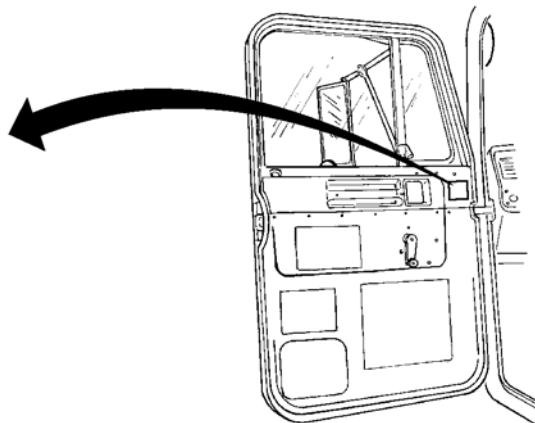
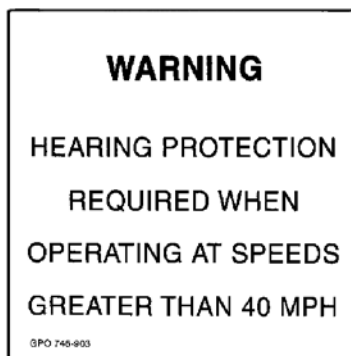

402-086

STOWAGE AND STENCILS

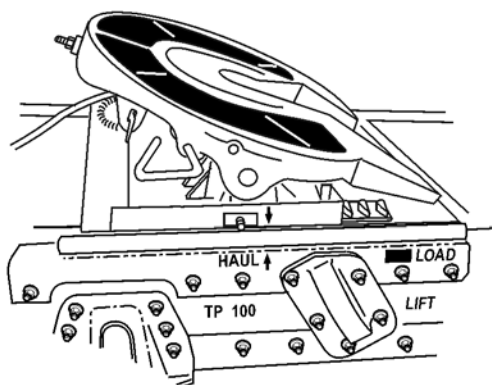

402-090

**STOWAGE AND DECAL, DATA PLATE,
AND STENCIL GUIDE - CONTINUED**

0007 00

STOWAGE AND STENCILS - CONTINUED

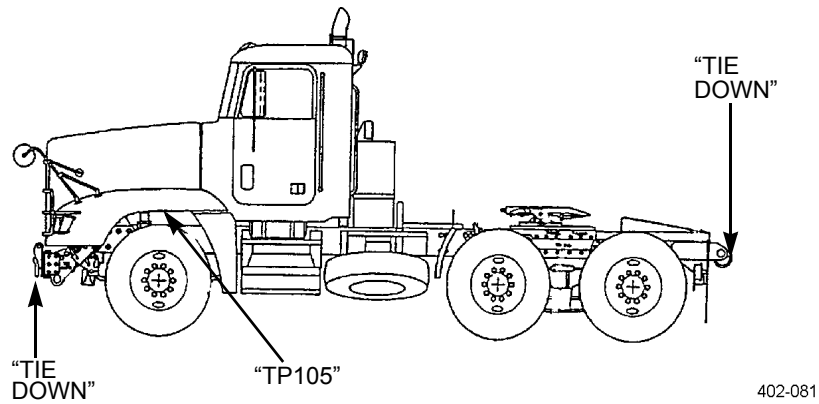
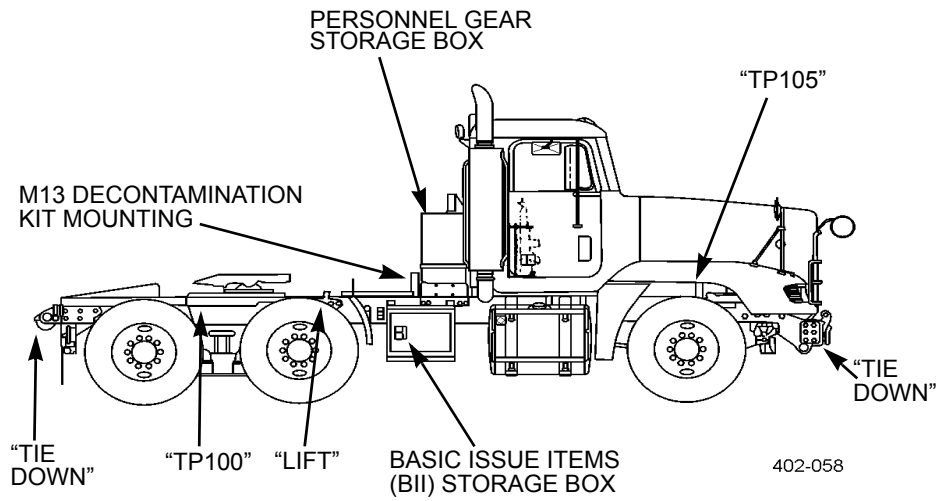

**STOWAGE AND DECAL, DATA PLATE,
AND STENCIL GUIDE - CONTINUED**

0007 00

STOWAGE AND STENCILS - CONTINUED

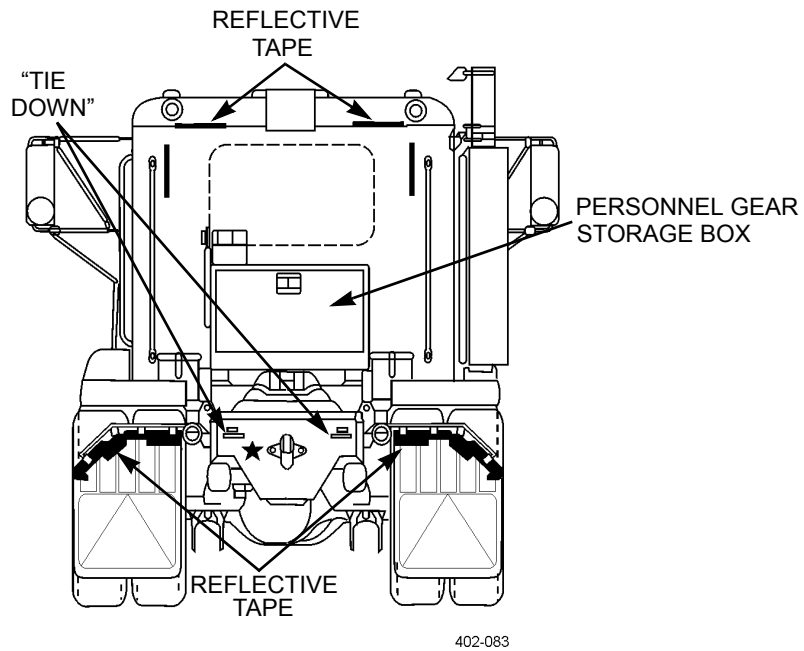
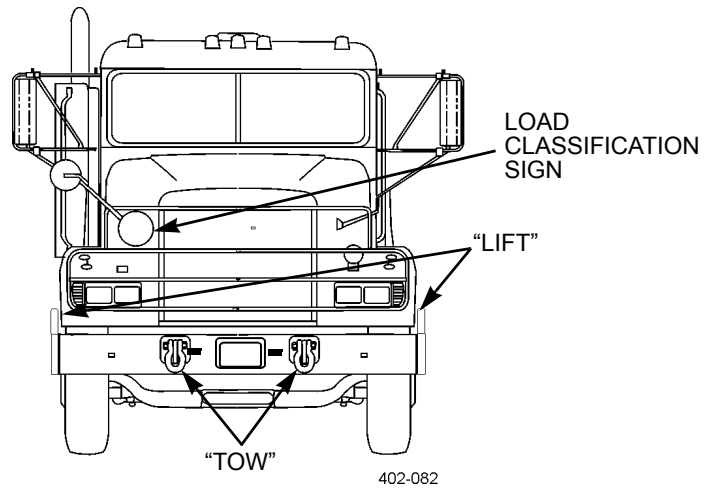

**STOWAGE AND DECAL, DATA PLATE,
AND STENCIL GUIDE - CONTINUED**

0007 00

STOWAGE AND STENCILS - CONTINUED

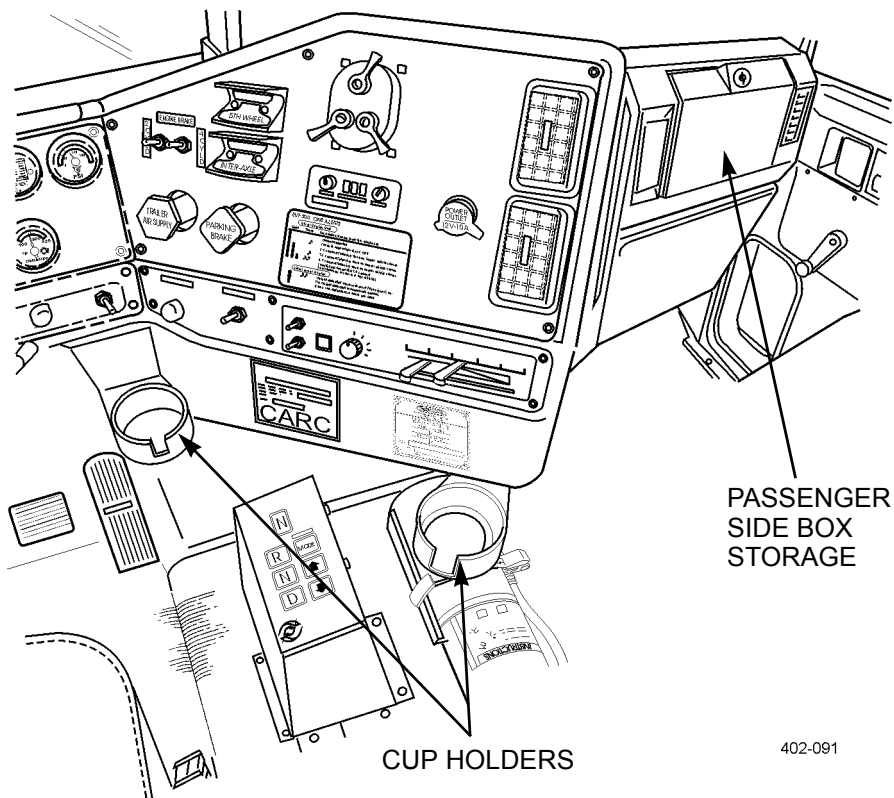
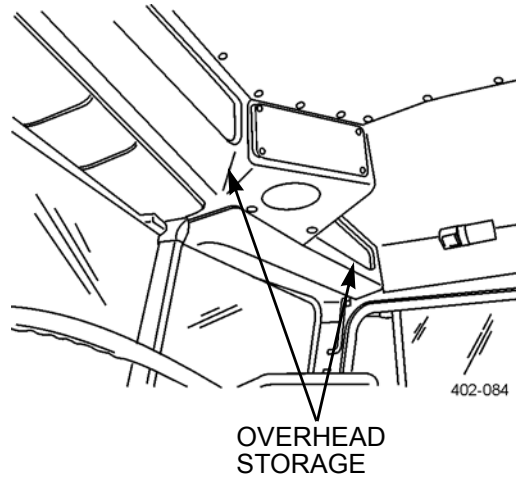

END OF WORK PACKAGE

TM 9-2320-303-10

CHAPTER 3
OPERATOR TROUBLESHOOTING

GENERAL

- a. This work package provides information for identifying and correcting malfunctions which may develop while operating the M915A4.
- b. The Troubleshooting Symptom Index in WP 0009 00 lists common malfunctions which may occur and refers you to the proper page in WP 0010 00 for a troubleshooting procedure.
- c. If you are unsure of the location of an item mentioned in troubleshooting, refer to WP 0002 00 or WP 0004 00.
- d. Before performing troubleshooting, read and follow all safety instructions found in the Warning Summary at the front of this manual.
- e. This troubleshooting index cannot list all malfunctions that may occur, nor all tests or inspections and corrective actions. If a malfunction is not listed, or is not corrected by the listed corrective actions, notify your supervisor.
- f. When troubleshooting a malfunction:
 - (1) Locate the symptom or symptoms in WP 0009 00 that best describe the malfunction.
 - (2) Turn to the page in WP 0010 00, Table 1 where the troubleshooting procedures for the malfunction in question are described. Headings at the top of each page show how each troubleshooting procedure is organized: MALFUNCTION, TEST OR INSPECTION (in step number order), and CORRECTIVE ACTION.
 - (3) Perform each step in the order listed until the malfunction is corrected. DO NOT perform any maintenance task unless the troubleshooting procedure tells you to do so.

EXPLANATION OF COLUMNS

The columns in WP 0010 00, Table 1 are defined as follows:

- a. **MALFUNCTION.** A visual or operational indication that something is wrong with the equipment.
- b. **TEST OR INSPECTION.** A procedure to isolate the problem in a system or component.
- c. **CORRECTIVE ACTION.** A procedure to correct the problem.

END OF WORK PACKAGE

TROUBLESHOOTING SYMPTOM INDEX **0009 00**

Malfunction/Symptom

Troubleshooting Procedure

AIR SYSTEM AND BRAKES

1. Air Reservoir Pressure Low (Warning Light and Buzzer are ON).....0010 00-1
2. Air System Loses Pressure During Vehicle Operation or
Low Air Pressure Warning Light and Buzzer Come On
During Vehicle Operation.....0010 00-1
3. Trailer Brakes Will Not Apply When Pedal or Hand Control on
Steering Column is Used.....0010 00-2
4. Trailer Brakes Will Not Release.....0010 00-3

CWS

1. System Failure Light is On.....0010 00-3
2. Side Sensor Failure Light is On.....0010 00-3

DRIVELINE LOCKING SYSTEM

- Driveline Will Not Disengage When Inter-axle Differential Control
Valve Lever is Moved to UNLOCK Position.....0010 00-3

ELECTRICAL SYSTEM

- One or More Lighting Systems Not Working.....0010 00-4

ENGINE

1. Engine Coolant Temperature Gage Indicates Engine is Overheating.....0010 00-4
2. Engine Cranks but Fails to Start.....0010 00-4
3. Engine Does Not Develop Full Power.....0010 00-5
4. Engine Does Not Idle Properly.....0010 00-5
5. Engine Fails to Crank When Starter Button is Pressed.....0010 00-5
6. Engine Starts but Misfires or Runs Rough After Proper Warmup Period.....0010 00-5
7. Excessive Engine Oil Consumption.....0010 00-5
8. Excessive Exhaust Smoke (At Normal Engine Operating Speed).....0010 00-5
9. Low or No Engine Oil Pressure.....0010 00-5

FIFTH WHEEL

1. Difficult to Uncouple from Trailer.....0010 00-6
2. Difficult to Couple to Trailer.....0010 00-6

TROUBLESHOOTING SYMPTOM INDEX - CONTINUED

0009 00

Malfunction/Symptom

Troubleshooting Procedure

STEERING

1. Hard Steering, Shimmy or Wandering0010 00-6
2. Vehicle Steering Slow or Intermittent to Respond0010 00-6

TRANSMISSION

1. Slow or Erratic Transmission Engagement0010 00-7
2. Transmission Fluid Temperature Gage Indicates Fluid
is Overheating During Normal Operation0010 00-7

WHEELS AND TIRES

1. Tires Worn Unevenly or Excessively0010 00-7
2. Vehicle Wanders or Pulls to One Side on Level Pavement0010 00-7
3. Wheel Wobbles0010 00-8

END OF WORK PACKAGE

Table 1. Troubleshooting Procedures .

MALFUNCTION	TEST OR INSPECTION	CORRECTIVE ACTION
AIR SYSTEM AND BRAKES		
<p>1. Air Reservoir Pressure Low (Warning Light and Buzzer are ON).</p>	<p>1. Ensure air tank drain valve(s) are closed.</p> <p>2. If vehicle is not coupled to a semitrailer, check position of trailer air supply control knob.</p> <p>3. Start engine and check for air leaks at air reservoirs, hoses, fittings, and intervehicular air hose connections.</p> <p>4. Perform semitrailer troubleshooting.</p>	<p>Close drain valve(s).</p> <p>Pull knob out (OFF).</p> <p>If air leaks are present, notify Unit Maintenance.</p>
<p>2. Air System Loses Pressure During Vehicle Operation or Low Air Pressure Warning Light and Buzzer Come On During Vehicle Operation.</p>	<p>1. Safely stop vehicle.</p>	<p style="text-align: center;">NOTE</p> <p>Any change in pressure on brake pedal will cause a change in air pressure reading.</p> <p>Ensure primary air reservoir drain is closed. If leaks are present, notify Unit Maintenance.</p>

Table 1. Troubleshooting Procedures - Continued.

MALFUNCTION	TEST OR INSPECTION	CORRECTIVE ACTION
<p>2. Air System Loses Pressure During Vehicle Operation or Low Air Pressure Warning Light and Buzzer Come On During Vehicle Operation - Continued.</p>	<p>2. Ensure trailer air supply control knob is pulled out (OFF). Operate engine until warning light and buzzer go off and release parking brake. Stop engine and note reservoir pressure. Fully press and hold service brake pedal for two minutes. Have crewmember check for leaks. Reservoir pressure loss during two minute period should not exceed 5 psi (34 kPa).</p>	
<p style="text-align: center;">NOTE</p>		
<p style="text-align: center;">Any change in pressure on brake pedal will cause a change in air pressure reading.</p>		
<p>3. Trailer Brakes Will Not Apply When Pedal or Hand Control on Steering Column is Used.</p>	<p>3. Push trailer air supply control knob in (ON) to charge semitrailer air reservoirs and repeat step 2.</p> <p>4. Check semitrailer for leaks. Pressure loss should not exceed 5 psi (34 kPa) in two minutes.</p> <p>1. Check for system air pressure.</p> <p>2. Check intervehicular air hoses for proper connections to semitrailer.</p>	<p>If air leaks are present or reservoir pressure loss exceeds 5 psi (34 kPa) in two minutes, refer to trailer TM.</p> <p>Connect air hoses.</p>

Table 1. Troubleshooting Procedures - Continued.

MALFUNCTION	TEST OR INSPECTION	CORRECTIVE ACTION
<p>4. Trailer Brakes Will Not Release.</p>	<p>1. Check position of trailer brake hand control.</p> <p>2. Check position of trailer air supply control knob.</p> <p>3. Check intervehicular air hoses for proper connections.</p> <p>4. Check for leaks or damage to vehicle components.</p>	<p>Move control to forward (OFF) position.</p> <p>Push knob in (ON).</p> <p>Connect air hoses.</p> <p>If leaks are not found and vehicle components are not damaged, refer to trailer TM.</p>
<p>COLLISION WARNING SYSTEM (CWS)</p>		
<p>1. System Failure Light is On.</p>	<p>Check antenna for cleanliness and damage.</p>	<p>Clean antenna. If antenna is damaged, notify Unit Maintenance.</p>
<p>2. Side Sensor Failure Light is On.</p>	<p>Check side sensor for cleanliness and damage.</p>	<p>1. Clean side sensor.</p> <p>2. Check for signal by waving hand in front of side sensor.</p> <p>3. If side sensor is damaged or signal is not received, notify Unit Maintenance.</p>
<p>DRIVELINE SYSTEM</p>		
<p>Driveline Will Not Disengage When Inter-axle Differential Control Valve Lever is Moved to UNLOCK Position.</p>	<p>Excessive driveline windup may have occurred. Back truck up slowly.</p>	<p>If driveline does not disengage, notify Unit Maintenance.</p>

Table 1. Troubleshooting Procedures - Continued.

MALFUNCTION	TEST OR INSPECTION	CORRECTIVE ACTION
<i>ELECTRICAL SYSTEM</i>		
<p>One or More Lighting Systems Not Working.</p>	<ol style="list-style-type: none"> 1. Check position of main light switch. If vehicle is coupled to semitrailer and problem is with semitrailer lighting system, check intervehicular cable connection. 2. Refer to trailer TM. 	<p>Place main light switch to BO Drive, STOP LIGHT, or SER DRIVE position. Connect inter-vehicular cables if coupled to trailer.</p>
<i>ENGINE</i>		
<p>1. Engine Coolant Temperature Gage Indicates Engine is Overheating.</p>	<ol style="list-style-type: none"> 1. Check coolant level in expansion tank. 2. Check system for leaks. 3. Check if A/C condenser is free of mud, snow, ice, or debris. 4. Check cooling fan drive belt for looseness. 5. Check engine oil level. 6. Check transmission fluid level. 	<p>If low, add coolant.</p> <p>If leaks are found, notify Unit Maintenance.</p> <p>Remove anything that blocks or impedes cooling.</p> <p>If belt is loose, notify Unit Maintenance.</p> <p>If engine oil is low, fill to correct level (WP 0017 00).</p> <p>If transmission fluid level is low, fill to correct level (WP 0004 00).</p>
<p>2. Engine Cranks but Fails to Start.</p>	<ol style="list-style-type: none"> 1. Check fuel gage with ignition switch in ON position. 2. Check air cleaner restriction indicator. 	<p>If empty, add fuel. If fuel is available, prime fuel system (WP 0017 00).</p> <p>If indicator is not clear, notify Unit Maintenance.</p>

Table 1. Troubleshooting Procedures - Continued.

MALFUNCTION	TEST OR INSPECTION	CORRECTIVE ACTION
3. Engine Does Not Develop Full Power.	Check air cleaner restriction indicator.	If indicator is not clear, notify Unit Maintenance.
4. Engine Does Not Idle Properly.	Check air cleaner restriction indicator.	If indicator is not clear, notify Unit Maintenance.
5. Engine Fails to Crank When Starter Button is Pressed.	<ol style="list-style-type: none"> 1. Check position of master battery switch. 2. Check position of ignition switch. 3. Check selection of transmission shift selector pushbuttons. 4. Check for dirty, loose, or damaged battery cables. 	<p>Place master battery switch in ON position.</p> <p>Place ignition switch in ON position.</p> <p>Select transmission shift selector N (Neutral) pushbutton.</p> <p>Clean dirty cables. Tighten loose connections at batteries, ground, and starter. If cable is damaged notify Unit Maintenance.</p>
6. Engine Starts but Misfires or Runs Rough After Proper Warmup Period.	<ol style="list-style-type: none"> 1. Check air cleaner restriction indicator. 2. Check fuel/water separator for moisture. 	<p>If indicator is not clear, notify Unit Maintenance.</p> <p>If moisture is present, open fuel/water separator drain valve.</p>
7. Excessive Engine Oil Consumption.	Check for loose oil lines and oil leaks.	If oil lines are loose or leaks are found, notify Unit Maintenance.
8. Excessive Exhaust Smoke (At Normal Engine Operating Speed).	<ol style="list-style-type: none"> 1. Check air cleaner restriction indicator. 2. Check for water in fuel. 	<p>If indicator is not clear, notify Unit Maintenance.</p> <p>Drain fuel filters (WP 0012).</p>
9. Low or No Engine Oil Pressure.	Check engine oil level.	If engine oil is low, fill to correct level (WP 0017 00).

Table 1. Troubleshooting Procedures - Continued.

MALFUNCTION	TEST OR INSPECTION	CORRECTIVE ACTION
FIFTH WHEEL		
1. Difficult to Uncouple from Trailer.	1. Check that secondary lock is released. 2. Check that tractor is not putting pressure against locks.	Release secondary lock. Lock trailer brakes and back tractor against kingpin. Lock tractor brakes and pull lock release handle.
2. Difficult to Couple to Trailer.	1. Check that locks are not closed. 2. Check for dirt, grime, or any other debris that would interfere with lock operation.	Pull release handle and verify that locks are open. Lubricate fifth wheel IAW lubrication instructions (WP 0017 00).
STEERING		
1. Hard Steering, Shimmy or Wandering.	NOTE	
	Check tire pressure when tires are cold.	
	1. Check that tires are properly inflated. 2. Check for loose lug nuts. 3. Check for worn, loose, or damaged parts on front axle or suspension. Check steering linkage, wheels, and vehicle frame for worn, loose, or damaged parts.	Inflate tires to proper pressure (WP 0012 00). Tighten loose lug nuts and notify Unit Maintenance to apply proper torque. If worn, loose, or damaged parts are found, notify Unit Maintenance.
2. Vehicle Steering Slow or Intermittent to Respond.	Check power steering fluid level.	If power steering fluid is low, fill to correct level (WP 0017 00).

Table 1. Troubleshooting Procedures - Continued.

MALFUNCTION	TEST OR INSPECTION	CORRECTIVE ACTION
TRANSMISSION		
1. Slow or Erratic Transmission Engagement.	Check transmission fluid level.	If transmission fluid is low, fill to correct level (WP 0017 00).
2. Transmission Fluid Temperature Gage Indicates Fluid is Overheating During Normal Operation.	<ol style="list-style-type: none"> 1. Ensure proper transmission range is selected for vehicle operation. 2. Check transmission fluid level. 3. Check transmission fluid dipstick for discoloration that would indicate water/coolant in fluid. 	<p>Select proper transmission range.</p> <p>If transmission fluid is low, fill to correct level (WP 0017 00).</p> <p>If dipstick is discolored, notify Unit Maintenance.</p>
WHEELS AND TIRES		
1. Tires Worn Unevenly or Excessively.	<ol style="list-style-type: none"> 1. Check tires for proper pressure. 2. Check for bent wheel rims. 3. Check for loose lug nuts. 	<p>Inflate tires to proper pressure (WP 0012 00).</p> <p>If rim is bent, replace wheel and tire assembly (WP 0014 00). Notify Unit Maintenance to apply proper torque.</p> <p>Tighten loose lug nuts and notify Unit Maintenance to apply proper torque.</p>
2. Vehicle Wanders or Pulls to One Side on Level Pavement.	<ol style="list-style-type: none"> 1. Check tires for proper pressure. 2. Check that tires are proper size and type. 	<p>Inflate tires to proper pressure (WP 0012 00).</p> <p>If one tire is mismatched and spare matches, replace mismatched tire with spare. If one or more tires are mismatched, notify Unit Maintenance.</p>

Table 1. Troubleshooting Procedures - Continued.

MALFUNCTION	TEST OR INSPECTION	CORRECTIVE ACTION
3. Wheel Wobbles.	1. Check for loose or missing lug nuts. 2. Check for bent wheel rims.	Tighten loose lug nuts and notify Unit Maintenance to apply proper torque. If lug nuts are missing, notify Unit Maintenance. If rim is bent, replace wheel and tire assembly (WP 0014 00). Notify Unit Maintenance to apply proper torque.

END OF WORK PACKAGE

TM 9-2320-303-10

CHAPTER 4
OPERATOR MAINTENANCE INSTRUCTIONS

**PREVENTIVE MAINTENANCE CHECKS
AND SERVICES (PMCS) INTRODUCTION**

0011 00

GENERAL

To ensure that the truck is ready for operation at all times, it must be inspected on a regular basis so that defects may be found and corrected before they result in serious damage, equipment failure, or injury to personnel. Table 1 in WP 0012 00 contains systematic instructions on inspections, adjustments, and corrections to be performed by the operator/crew to keep the equipment in good operating condition and ready for its primary mission.

EXPLANATION OF TABLE ENTRIES

- a. **Item Number (Item No.) Column.** Numbers in this column are for reference. When completing DA Form 2404 or DA Form 5988-E (*Equipment Inspection and Maintenance Worksheet*), include the item number for the check/service indicating a fault. Item numbers also appear in the order that you must perform checks and services for the interval listed.
- b. **Interval Column.** This column tells you when you must perform the procedure in the procedure column.
 - (1) *Before* procedures must be done immediately before you operate the truck.
 - (2) *During* procedures must be done while you are operating the truck.
 - (3) *After* procedures must be done immediately after you have operated the truck.
 - (4) *Weekly* procedures must be done once each week.
 - (5) *Monthly* procedures must be done once each month.
- c. **Location, Item to Check/Service Column.** This column provides the location and item to be checked or serviced. The item location is underlined.

NOTE

The WARNINGS and CAUTIONS appearing in your PMCS table should always be observed. WARNINGS and CAUTIONS appear before applicable procedures. You must observe these WARNINGS to prevent serious injury to yourself and others, and CAUTIONS to prevent your equipment from being damaged.

- d. **Procedure Column.** This column gives the procedure you must perform to check or service the item listed in the Item to Check/Service column to know if the equipment is ready or available for its intended mission or for operation. You must perform the procedure at the time stated in the interval column.
- e. **Not Fully Mission Capable If: Column.** Information in this column tells you what faults will keep your equipment from being capable of performing its primary mission. If you make check and service procedures that show faults listed in this column, the equipment is not mission-capable. Follow standard operating procedures for maintaining the equipment or reporting equipment failure.

**PREVENTIVE MAINTENANCE CHECKS
AND SERVICES (PMCS) INTRODUCTION - CONTINUED**

0011 00

GENERAL PMCS PROCEDURES

- a. Always perform PMCS in the same order so it gets to be a habit. Once you've had some practice, you'll spot anything wrong in a hurry. If the truck does not perform as required, refer to the appropriate troubleshooting procedure in Chapter 3.
- b. If anything looks wrong and you can't fix it, write it on your DA Form 2404 or DA Form 5988-E. If you find something seriously wrong, IMMEDIATELY report it to your supervisor.
- c. Before performing preventive maintenance block wheels (Item 6, WP 0019 00), read all the checks required for the applicable interval and prepare all the tools you need to make all the checks. You'll always need a rag (Item 16, WP 0021 00) or two.
 - (1) **Keep It Clean.** Dirt, grease, oil, and debris get in the way and may cover up a serious problem. Clean as you work and as needed. Use detergent (Item 4, WP 0021 00) and water when you clean rubber, plastic, and painted surfaces.
 - (2) **Rust and Corrosion.** Check metal parts for rust and corrosion. If any bare metal or corrosion exists, clean and apply a light coat of lubricating oil (Item 12, WP 0021 00). Report it to your supervisor.
 - (3) **Bolts, Nuts, and Screws.** Check bolts, nuts, and screws for obvious looseness, missing, bent, or broken condition. You can't try them all with a tool, but look for chipped paint, bare metal, or rust around bolt heads. If you find one you think is loose, tighten it.
 - (4) **Welds.** Look for loose or chipped paint, rust, or gaps where parts are welded together. If you find a bad weld, report it to your supervisor.
 - (5) **Electric Wires and Connectors.** Look for cracked or broken insulation, bare wires, and loose or broken connectors. Tighten loose connectors and ensure that the wires are in good condition.
 - (6) **Hoses and Fluid Lines.** Look for wear, damage, and signs of leaks. Ensure that clamps and fittings are tight. Wet spots indicate leaks, but a stain around a fitting or connector can also mean a leak. If a leak comes from a loose fitting or connector, tighten it. If something is broken or worn out, report it to your supervisor.
 - (7) **Fluid Leakage.** It is necessary for you to know how fluid leakage affects the status of your truck. The following are definitions of the types/classes of leakage you need to know to be able to determine the status of your truck. Learn and be familiar with them, and remember - when in doubt, notify your supervisor.

**PREVENTIVE MAINTENANCE CHECKS
AND SERVICES (PMCS) INTRODUCTION - CONTINUED**

0011 00

CAUTION

- Equipment operation is allowed with minor leakages (Class I or II). Consideration must be given to fluid capacity in the item/system being checked/inspected. When in doubt, notify your supervisor.
- When operating with Class I or II leaks, continue to check fluid levels as required in the PMCS.
- Class III leaks should be reported immediately to your supervisor.

Leakage Definitions for PMCS

Class I	Seepage of fluid (as indicated by wetness or discoloration) not great enough to form drops.
Class II	Leakage of fluid great enough to form drops, but not enough to cause drops to drip from item being checked/inspected.
Class III	Leakage of fluid great enough to form drops that fall from item being checked/inspected.

END OF WORK PACKAGE

Table 1. Preventive Maintenance Checks and Services (PMCS) for M915A4 .

Item No.	Interval	Location	Procedure	Not Fully Mission Capable If:
		Item To Check/ Service		
1	Before	NOTE		
		<ul style="list-style-type: none"> • Review all WARNINGS, CAUTIONS, and NOTES before performing PMCS and operating the truck. • Perform all PMCS checks if: <ul style="list-style-type: none"> a. You are the assigned operator but have not operated the truck since the last weekly inspection. b. You are operating the truck for the first time. 		
		FRONT AND LEFT SIDE		
		Overall View	<ul style="list-style-type: none"> a. Check under truck for evidence of fluid leakage such as oil, coolant, or fuel. b. Check truck for obvious damage that would impair operation. c. Check tires for defects, underinflation or loose or missing wheel studs or lug nuts. 	<ul style="list-style-type: none"> a. Class III oil, coolant, or fuel leaks are evident. b. Damage that would impair operation is evident. c. Tire is missing, deflated, unserviceable or two or more wheel studs or lug nuts are missing.

Table 1. Preventive Maintenance Checks and Services (PMCS) for M915A4 - Continued.

Item No.	Interval	Location	Procedure	Not Fully Mission Capable If:
		Item To Check/Service		
2	Before	Cab Exterior	Check for damage to lights (10), spotting mirrors (1), side mirror (4), windshield (2), windshield wipers and blades (3), cab door (9), grabhandle (5), battery box and steps (8), master battery switch (7) and CWS antenna (11).	Damage that would interfere with visibility and impair operation is evident.
3	Before	Spare Wheel and Tire	Check for presence and condition of spare wheel and tire (6).	
4	Before	REAR AND RIGHT SIDE Overall View	<p>a. Check under truck for evidence of fluid leakage such as oil, coolant, or fuel.</p> <p>b. Check truck for obvious damage that would impair operation.</p>	<p>a. Class III oil, coolant, or fuel leaks are evident.</p> <p>b. Damage that would impair operation is evident.</p>

Table 1. Preventive Maintenance Checks and Services (PMCS) for M915A4 - Continued.

Item No.	Interval	Location	Procedure	Not Fully Mission Capable If:		
		Item To Check/Service				
4 (Con't)	Before	Overall View	c. Check tires for defects, underinflation or loose or missing wheel studs or lug nuts.	c. Tire is missing, deflated, unserviceable or two or more wheel studs or lug nuts are missing.		
5		Cab Exterior	Check for damage to lights (10), side mirror (12), cab door (9), grabhandles (5), steps (14), and CWS side sensor (13).	Damage that would interfere with visibility and impair operation is evident.		
 <p style="text-align: right; margin-right: 100px;">402-021</p>						
6	Before	<table border="1" style="width: 100%; border-collapse: collapse;"> <tr> <td style="text-align: center; padding: 5px;">CAB INTERIOR</td> </tr> <tr> <td style="text-align: center; padding: 5px;">Instrument Panel</td> </tr> </table>	CAB INTERIOR	Instrument Panel	<p style="text-align: center;">NOTE</p> <p>Refer to WP 0004 00 for the location of all gages, switches, and indicator lights.</p> <p>Check for damage to gages, switches, and indicator and warning lights.</p>	<p>Any gage is broken or unreadable.</p>
CAB INTERIOR						
Instrument Panel						

Table 1. Preventive Maintenance Checks and Services (PMCS) for M915A4 - Continued.

Item No.	Interval	Location	Procedure	Not Fully Mission Capable If:
		Item To Check/Service		
7	Before	Fire Extinguisher	a. Check for missing or damaged fire extinguisher (15). b. Check gage (16) for proper pressure of approximately 150 psi (1034 kPa). c. Check for damaged or missing seal (17).	a. Fire extinguisher is missing or damaged. b. Pressure gage needle is in recharge area. c. Seal is broken or missing.
8	Before	Engine Startup	a. Start engine (WP 0005 00). Verify that CHK TRANS light (18), low air pressure warning light (19) and warning buzzer turn off.	a. Engine will not start. Low air pressure or warning light and warning buzzer stay on.

Table 1. Preventive Maintenance Checks and Services (PMCS) for M915A4 - Continued.

Item No.	Interval	Location	Procedure	Not Fully Mission Capable If:
		Item To Check/Service		
8 (Con't)	Before	Engine Startup	<p>CAUTION</p> <p>Care must be exercised if tractor or trailer ABS light comes on while driving, possibly indicating an ABS malfunction. Although the regular/normal vehicle system is still fully operational, you should continue in a safe manner and reduce speed to 40 mph (64 kph), until the mission is complete. When the mission is complete, report to Unit Maintenance to clear the ABS fault and restore full ABS capabilities.</p> <p>b. Check that ABS indicator lights (20) turns off after 5-10 second self-test. If not, notify supervisor.</p>	
				
			<p>CAUTION</p> <p>DO NOT run engine above idle speed until oil pressure gage indicates at least 5-20 psi (34.4- 138 kPa) at idle speed.</p> <p>c. Check engine rpm on tachometer.</p> <p>b. At idle, engine speed is not 600 rpm.</p>	

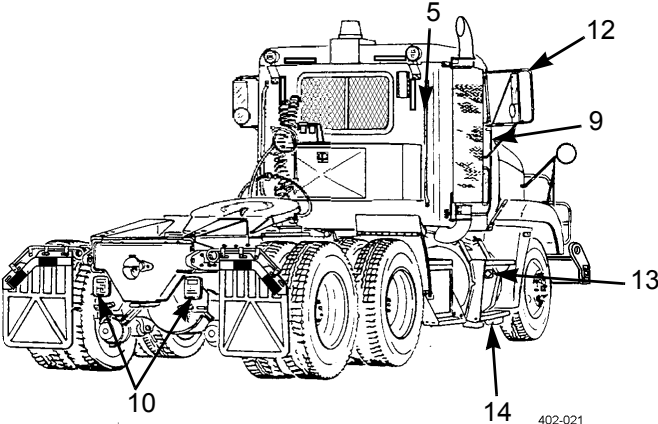
Table 1. Preventive Maintenance Checks and Services (PMCS) for M915A4 - Continued.

Item No.	Interval	Location	Procedure	Not Fully Mission Capable If:
		Item To Check/Service		
9	Before	Seats and Seat Belts	<p>a. Check seats (22) and seat belts (21) for security of mounting and damage</p> <p style="text-align: center;">NOTE</p> <p>All adjustments should be made while seated. Primary air pressure gage must indicate a minimum of 60 psi (414 kPa) to adjust height of seat.</p> <p>b. Check for proper operation of seat height adjustment valve lever (24) and fore and aft seat adjustment lever (26). Check for proper operation of lumbar adjustment knob (27), seat back adjustment lever (23), and seat tilt knob (25).</p>	<p>a. Seat belts are not serviceable.</p> <p>b. Seat missing or inoperative.</p>

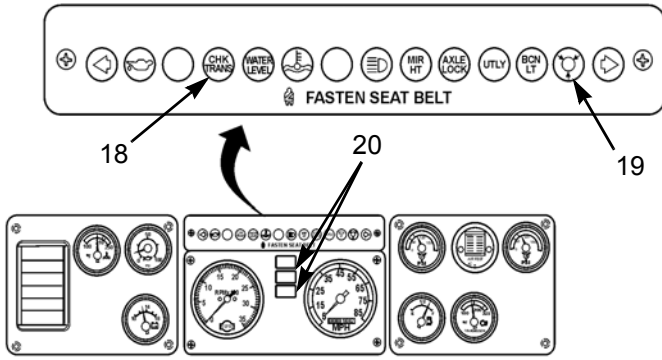
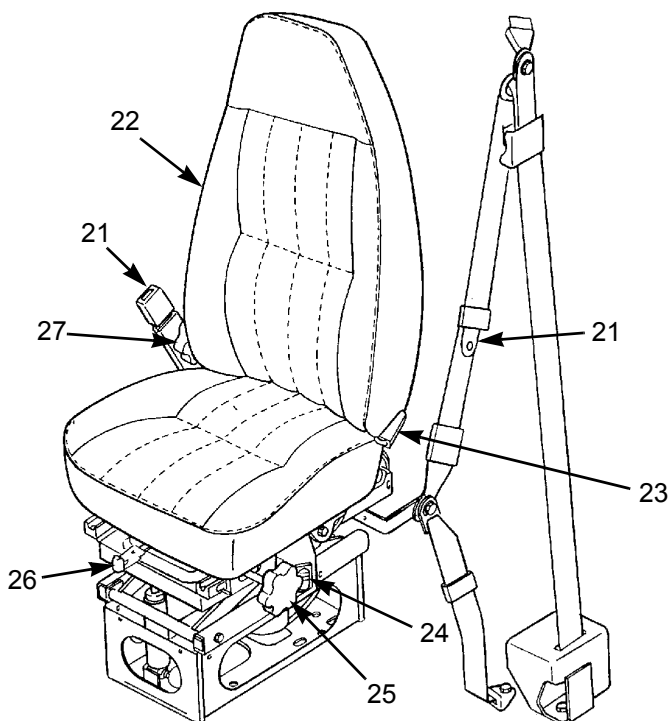

402-034

TM 9-2320-303-10

Table 1. Preventive Maintenance Checks and Services (PMCS) for M915A4 - Continued.

Item No.	Interval	Location	Procedure	Not Fully Mission Capable If:
		Item To Check/Service		
10	Before	Steering Wheel	Adjust tilt and height of steering wheel.	Steering wheel does not lock into adjusted position.
11	Before	Side Mirrors	Adjust side mirrors as required.	
12	Before	Instrument Panel Gages and Indicator and Warning Lights	<p style="text-align: center;">CAUTION</p> <p>At 2100 rpm, minimum engine oil pressure for safe operation is 40-75 psi (276-517 kPa). If gage does not show at least 40 psi (276 kPa), shut down engine and notify supervisor. All warning lights should go out in approximately 7 seconds. Failure to follow this caution will damage engine.</p> <p>a. Check oil pressure gage. Reading should be 5-20 psi (34.4-138 kPa) at idle.</p> <p>b. Check primary and secondary air pressure gages for 90-120 psi (621-827 kPa) (green band).</p> <p>c. Check that voltmeter registers within green band.</p> <p>d. Check that fuel supply gage registers and indicates adequate fuel for mission.</p> <p>e. Check air cleaner restriction indicator.</p>	
13	Before	Parking Brake	With service brake pedal depressed, transmission in Drive (D), and engine at idle, pull out on parking brake valve, then release service brake pedal. Vehicle should not move.	Vehicle moves with parking brake applied.

Table 1. Preventive Maintenance Checks and Services (PMCS) for M915A4 - Continued.

Item No.	Interval	Location	Procedure	Not Fully Mission Capable If:
		Item To Check/ Service		
14	Before	Service Brakes	With transmission in Drive (D), release parking brake and apply service brakes. Vehicle should not move.	Vehicle moves with service brakes applied.
15	Before	Trailer Brakes	<p style="text-align: center;">NOTE</p> <p>Perform this check with trailer after tractor/trailer are coupled.</p> <p>a. Listen for air leaks at intervehicular connecting hoses, relay valve, and air reservoirs.</p> <p>b. Apply trailer brakes only and attempt to move tractor/trailer combination.</p>	<p>a. Any air leaks are present.</p> <p>b. Brakes fail to hold tractor/trailer combination from moving.</p>
16	During	Instrument Panel/CWS Displays	<p style="text-align: center;">CAUTION</p> <p>Care must be exercised if tractor or trailer ABS light comes on while driving, possibly indicating an ABS malfunction. Although the regular/normal vehicle system is still fully operational, you should continue in a safe manner and reduce speed to 40 mph (64 kph), until the mission is complete. When the mission is complete, report to Unit Maintenance to clear the ABS fault and restore full ABS capabilities.</p> <p>a. Monitor all gages and indicator and warning lights. Check that engine coolant and transmission oil temperature gages register within normal range (green band).</p> <p>b. Monitor indicator lights on driver's display unit and side sensor display. If system fail light illuminates, continue mission and turn CWS off. Notify supervisor.</p>	<p>a. Any red warning light except ABS light(s) stays on.</p>

TM 9-2320-303-10

Table 1. Preventive Maintenance Checks and Services (PMCS) for M915A4 - Continued.

Item No.	Interval	Location	Procedure	Not Fully Mission Capable If:
		Item To Check/ Service		
17	During	Brakes	a. Check brakes for pulling or grabbing. b. Check that brake pedal is firm and does not fully depress to floor.	a. Brakes pull or grab. b. Brake pedal is spongy or depresses fully to floor.
18	During	Steering	Check for smooth steering without pulling to one side or excessive play [more than 2½ in. (6.4 cm)] in steering wheel.	Steering is erratic, pulls, or has excessive play.
19	During	Power Train	Check for unusual noise or vibration from engine, transmission, drive shafts, axles, and wheels.	Unusual noise or vibration is present.
20	During	Air Conditioner	NOTE Perform the following inspection only if air conditioner is required due to climatic conditions. Turn air conditioner on and set blower to maximum cooling speed settings. Wait five minutes to allow temperature to stabilize. Check outlet ducts for cool air. If air is not cooler than ambient temperature, notify supervisor.	
21	During	Overall Leakage	Be alert for evidence of fluid leakage.	Class III oil, coolant, or fuel leaks are evident.
		FRONT AND LEFT SIDE		
22	After	Overall View	a. Check under truck for evidence of fluid leakage such as oil, coolant or fuel. b. Check front gladhands for damage. Ensure that gladhand vent holes are not plugged. Ensure that dummy couplings are installed.	a. Class III oil, coolant, or fuel leaks are evident.

Table 1. Preventive Maintenance Checks and Services (PMCS) for M915A4 - Continued.

Item No.	Interval	Location	Procedure	Not Fully Mission Capable If:
		Item To Check/Service		
22 (Con't)	After	Overall View	c. Check truck for obvious damage that would impair operation. d. Check for damage to front service and blackout lights and marker clearance lights. e. Check CWS antenna and side sensor for obvious damage.	c. Damage that would impair operation is evident. d. Lights are damaged.
23	After	Wheels and Tires	<p style="text-align: center;">WARNING</p> Operating truck with an underinflated or defective tire may lead to tire failure and loss of steering control. Damage to equipment or injury to personnel may result. Check all tires for defects, underinflation, or loose or missing wheel studs or lug nuts.	Tire is missing, deflated, unserviceable, or two or more wheel studs or lug nuts are missing.
24	After	Front Axle Wheel Bearings	Check that lubricating oil is visible in sight glass (28) and rubber plug (29) is installed. If oil is not visible in sight glass, remove plug and add until level is even with plug opening (WP 0017 00).	

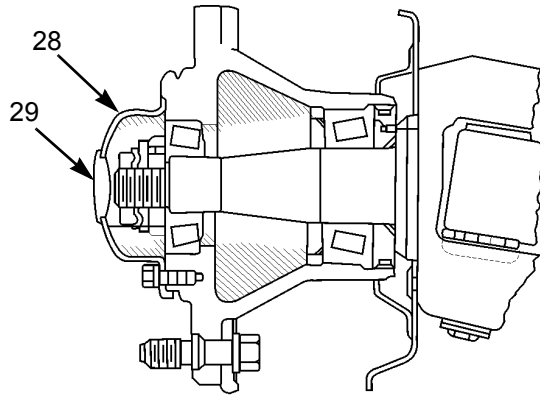

402-047

Table 1. Preventive Maintenance Checks and Services (PMCS) for M915A4 - Continued.

Item No.	Interval	Location	Procedure	Not Fully Mission Capable If:
		Item To Check/Service		
25	After	Power Steering Reservoir	With fluid at operating temperature and engine running, remove dipstick (30) and check level of power steering fluid in reservoir (31). Add fluid as required if level is below add mark (WP 0017 00).	

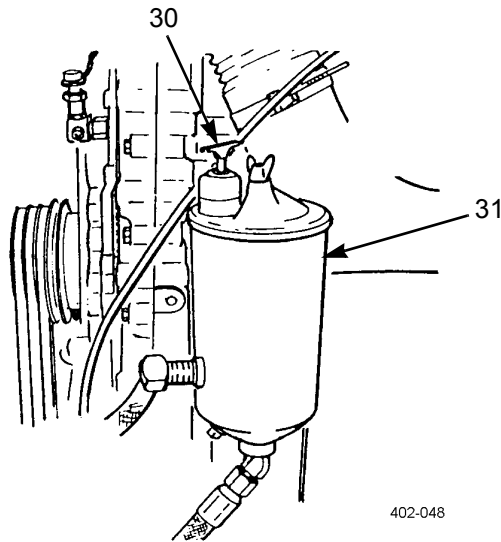

Table 1. Preventive Maintenance Checks and Services (PMCS) for M915A4 - Continued.

Item No.	Interval	Location	Procedure	Not Fully Mission Capable If:
		Item To Check/Service		
26	After	Fuel Filters	<p>WARNING</p> <p>DO NOT perform fuel system checks, inspections, or maintenance while smoking or near fire, flames, or sparks. Fuel may ignite, causing damage to vehicle and injury or death to personnel.</p> <p>If water or sediment is visible, turn drain knob (33) counterclockwise and drain all water from fuel filters (32). Turn knob clockwise to close.</p>	
				402-015

Table 1. Preventive Maintenance Checks and Services (PMCS) for M915A4 - Continued.

Item No.	Interval	Location	Procedure	Not Fully Mission Capable If:
		Item To Check/Service		
27	After	Intervehicular Air Hoses and Electrical Connectors	Check for presence and general condition of intervehicular air hoses (37), gladhands (35), gladhand preformed packings (38), and three electrical connectors (34). Check air hose retainer (36) for damage.	Air hose, gladhand, or electrical connector is damaged.

Table 1. Preventive Maintenance Checks and Services (PMCS) for M915A4 - Continued.

Item No.	Interval	Location	Procedure	Not Fully Mission Capable If:
		Item To Check/Service		
28	After	Fifth Wheel	<p>a. Check fifth wheel lube plates (40) for severe chips, wear, cracks, gouges or bends. Check if 25% or more of lube plate coating is missing from one or both plates due to normal wear or damage.</p> <p>b. Check for operation and damage to lock release levers (43), slide locking plungers (42), sliding rails (41), and fifth wheel plate (39).</p>	<p>a. One or both lube plates are loose, missing or damaged.</p> <p>b. Lock release levers do not operate. Locking jaw mechanism is cracked or worn.</p>
29	After	<p>REAR AND RIGHT SIDE</p> <p>Overall View</p>	<p>a. Check under truck for evidence of fluid leakage such as oil, coolant or fuel.</p> <p>b. Check rear gladhands for damage. Ensure that gladhand vent holes are not plugged. Ensure that dummy couplings are installed.</p>	<p>a. Class III oil, coolant, or fuel leaks are evident.</p>

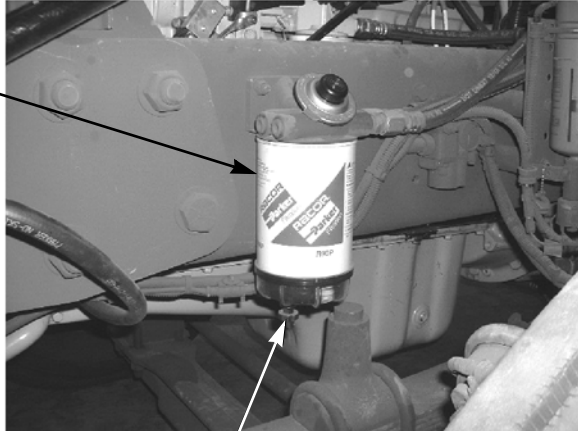
Table 1. Preventive Maintenance Checks and Services (PMCS) for M915A4 - Continued.

Item No.	Interval	Location	Procedure	Not Fully Mission Capable If:
		Item To Check/Service		
29 (Con't)	After	Overall View	<p>c. Check truck for obvious damage that would impair operation.</p> <p>d. Check for damage to rear service and blackout lights and marker clearance lights.</p> <p>e. Check for damage to exhaust system components. Ensure that components are securely mounted and are not leaking.</p> <p>f. Check CWS side sensor for obvious damage.</p>	<p>c. Damage that would impair operation is evident.</p> <p>d. Lights are damaged.</p> <p>e. Exhaust system components are damaged.</p>
30	After	Wheels and Tires	<p style="text-align: center;">WARNING</p> <p>Operating truck with an underinflated or defective tire may lead to tire failure and loss of steering control. Damage to equipment or injury to personnel may result.</p> <p>Check all tires for defects, underinflation, or loose or missing wheel studs or lug nuts.</p>	<p>Tire is missing, deflated, unserviceable, or two or more wheel studs or lug nuts are missing.</p>

Table 1. Preventive Maintenance Checks and Services (PMCS) for M915A4 - Continued.

Item No.	Interval	Location	Procedure	Not Fully Mission Capable If:
		Item To Check/Service		
31	After	Fifth Wheel Ramps	Check for damage to fifth wheel ramps (44).	Damage that prevents coupling.
32	After	Taillights	Check for damage to taillights (45).	Taillights are damaged.
33	After	Trailer Glad-hands	Check for presence of dummy couplings (48) and damage to trailer gladhands (46).	Damage that prevents air from applying trailer brakes when coupled.
34	After	Mud Flaps	Check for presence and general condition of mud flaps (47).	Mud flaps are missing.
				
35	After	Fuel Tank	<p style="text-align: center;">WARNING</p> <p>DO NOT smoke or permit any open flame in area of truck while servicing diesel fuel system. Be sure hose nozzle is grounded against filler tube during refueling to prevent static electricity. Failure to follow this warning may result in injury to personnel or equipment damage.</p> <p>a. Check for presence and condition of fuel filler cap (50).</p>	<p>a. Filler cap is missing or damaged.</p>

Table 1. Preventive Maintenance Checks and Services (PMCS) for M915A4 - Continued.

Item No.	Interval	Location	Procedure	Not Fully Mission Capable If:
		Item To Check/Service		
35 (Con't)	After	Fuel Tank	<p>b. Check fuel tank (49) for leaks, damage, and security of mounting.</p> <p>c. Remove fuel tank filler cap (50) and fill fuel tank (49) to holes [approximately 3 in. (7.6 cm)] in filler neck. Ensure that filler cap is free of debris and other material that could interfere with air venting. Install filler cap.</p>	b. Class III fuel leaks are evident.
 <p>The diagram shows a fuel tank assembly. Callout 49 points to the fuel tank body, and callout 50 points to the filler cap on the filler neck. The tank is mounted on a frame with a perforated base.</p>				
402-050				

Table 1. Preventive Maintenance Checks and Services (PMCS) for M915A4 - Continued.

Item No.	Interval	Location	Procedure	Not Fully Mission Capable If:
		Item To Check/Service		
36	After	Front Axle Wheel Bearings	Check that lubricating oil is visible in sight glass (51) and rubber plug (52) is installed. If oil is not visible in sight glass, remove plug and add until level is even with plug opening (WP 0017 00).	
 <p style="text-align: right; margin-right: 100px;">402-047</p>				
37	After	Transmission	<p style="text-align: center;">CAUTION</p> <p>Transmission must not be operating for extended periods of time until a Hot Check has verified proper fluid level. Transmission damage can result from extended operation at improper fluid level conditions.</p>	

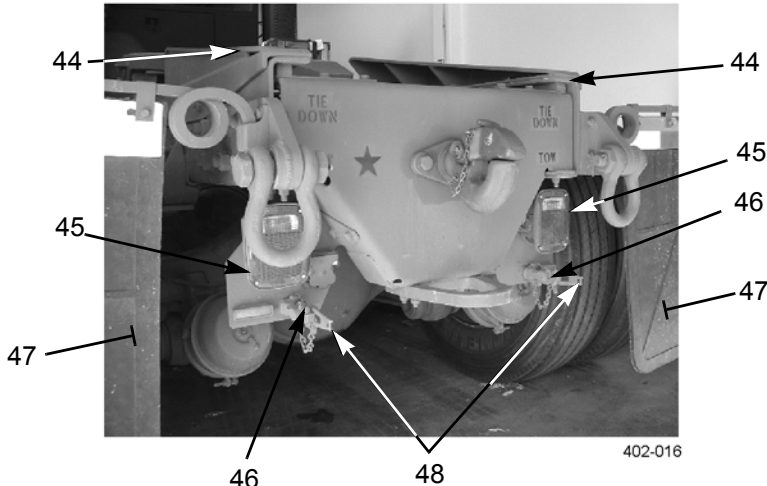
TM 9-2320-303-10

Table 1. Preventive Maintenance Checks and Services (PMCS) for M915A4 - Continued.

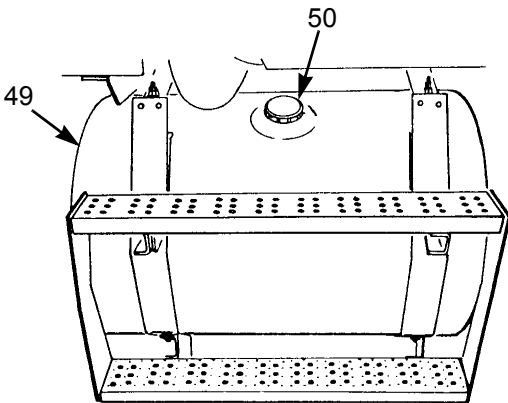
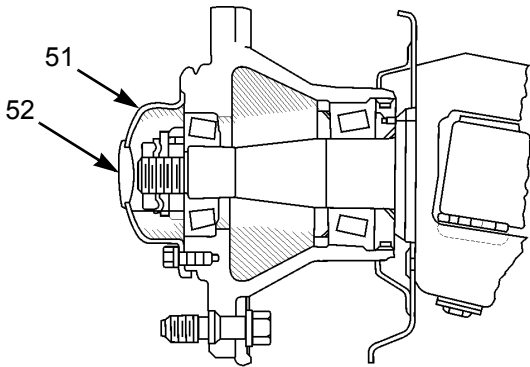
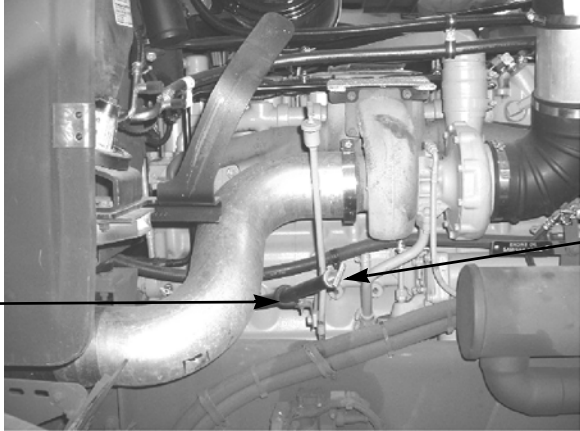
Item No.	Interval	Location	Procedure	Not Fully Mission Capable If:
		Item To Check/Service		
37 (Con't)	After	Transmission	With truck on level ground, perform hot oil check (WP 0017 00). Add transmission fluid as required through fill tube (53) until level on dipstick (54) is correct (WP 0017 00). Shut down engine.	
				
402-017				

TM 9-2320-303-10

Table 1. Preventive Maintenance Checks and Services (PMCS) for M915A4 - Continued.

Item No.	Interval	Location	Procedure	Not Fully Mission Capable If:
		Item To Check/Service		
38	After	Engine Crank-case	<p>NOTE</p> <p>To ensure an accurate reading, vehicle must be parked on level ground. Wait 10 minutes after shutting down engine to allow oil to drain into crank-case.</p> <p>Remove dipstick (55) and check level of lubricating oil. Safe operating level is between ADD and FULL marks on dipstick. If level is low, add oil until level on dipstick is correct (WP 0017 00).</p>	
				
39	After	Radiator	<p>WARNING</p> <p>DO NOT remove radiator cap unless engine is cold. Remove cap in two steps. First, place thick cloth over cap and slowly turn cap left to first stop. Pause and allow pressure to escape. Turn cap further left until it can be removed. This is a pressurized cooling system and escaping steam, hot water or coolant will cause serious burns.</p>	

Table 1. Preventive Maintenance Checks and Services (PMCS) for M915A4 - Continued.

Item No.	Interval	Location	Procedure	Not Fully Mission Capable If:
		Item To Check/Service		
39 (Con't)	After	Radiator	Remove radiator cap (56) and check coolant level in radiator (57). Coolant must be within 2½ in. (6.4 cm) below filler neck. Add coolant as required (WP 0017 00).	
 <p style="text-align: right;">402-051</p>				
40	After	Horns	<p style="text-align: center;">NOTE</p> <p>Vehicle operation with inoperative horn may violate AR 385-55.</p> <p>If tactical situation permits, check operation of electrical and air horns.</p>	
41	After	Accessory Items	Verify that windshield wipers and heater/ventilator or air conditioner operate. Add windshield washer fluid as required (WP 0017 00).	

Table 1. Preventive Maintenance Checks and Services (PMCS) for M915A4 - Continued.

Item No.	Interval	Location	Procedure	Not Fully Mission Capable If:
		Item To Check/ Service		
42	After	Lights	<p align="center">NOTE</p> <p>Vehicle operation with damaged or inoperative headlights or stoplights may violate AR 385-55.</p> <p>a. Check for presence and operation of service drive, turn signal, blackout marker, blackout drive, and marker clearance lights.</p> <p>b. Check operation of tail/stoplights. Depress brake pedal approximately ¼ in. (6.4 mm). Tail/stoplights should come on.</p> <p>a. Service drive lights do not operate (night time only).</p> <p>b. Taillights do not operate (night time only).</p>	
43	After	Front Axle Stops	<p>Check loose, missing or damaged front axle stops.</p> <p align="center">WARNING</p> <p>Ether is highly flammable and explosive. DO NOT perform ether quick-start system checks or inspections while smoking or near fire, flame or sparks. Failure to follow this warning may cause a fire and explosion, causing serious injury or death to personnel.</p>	
44	After	Ether Quick-start System	<p>Check for loose connections and damage to lines, fittings, and canister. Be alert for the odor of leaking ether.</p>	
45	Weekly	Drive Belts	<p>a. Check for loose, missing, broken, frayed, or cracked drive belts (59). Notify supervisor if loose drive belts are suspected.</p> <p>a. Any drive belt is loose, missing, broken, cracked to the belt fiber, has more than one crack 1/8 in. (3.2 mm) in depth, or has frays more than 2 in. (5.1 cm) long.</p>	

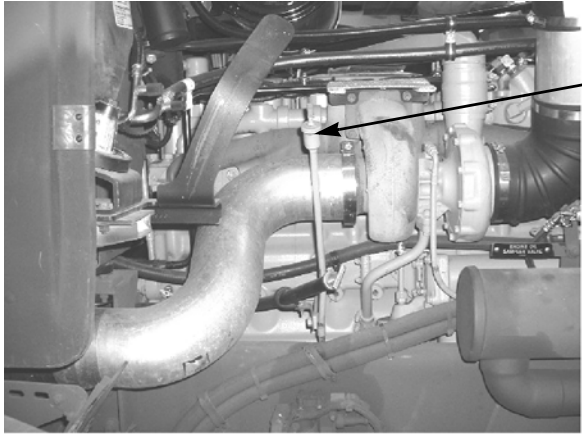
Table 1. Preventive Maintenance Checks and Services (PMCS) for M915A4 - Continued.

Item No.	Interval	Location	Procedure	Not Fully Mission Capable If:
		Item To Check/Service		
45 (Con't)	Weekly	Drive Belts	b. Check for damaged pulleys (58).	b. Pulley is damaged.
				
46	Weekly	Windshield Washer Reservoir	Check level of fluid in reservoir located in engine compartment below driver windshield on left firewall. Add windshield cleaning compound (Item 3, WP 0021 00) as required.	
47	Weekly	Front Wheel and Tire	<p style="text-align: center;">WARNING</p> <p>Operating truck with an underinflated or defective tire may lead to tire failure and loss of steering control. Damage to equipment or injury to personnel may result.</p> <p>a. Check pressure in tires and adjust as required: 105 psi (724 kPa)</p> <p>b. Ensure all wheel stud lug nuts are tight, using wheel stud lug nut wrench and handle.</p>	b. Two or more wheel studs are missing or lug nuts are loose.

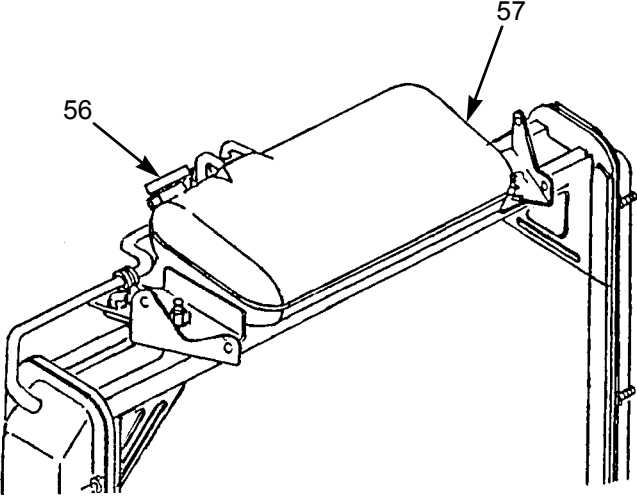
Table 1. Preventive Maintenance Checks and Services (PMCS) for M915A4 - Continued.

Item No.	Interval	Location	Procedure	Not Fully Mission Capable If:
		Item To Check/ Service		
47 (Con't)	Weekly	Front Wheel and Tire	c. Check wheel for cracks, breaks, or bends.	c. Wheel is cracked, broken, or bent.
48	Weekly	Batteries	<p style="text-align: center;">WARNING</p> <p>To avoid eye injury, eye protection is required when working around batteries. Do NOT smoke, use open flame, make sparks, or create other ignition sources around batteries. If a battery is giving off gases, it can explode and cause injury to personnel. Remove all jewelry, such as rings, ID tags, watches, and bracelets. If jewelry or a tool contacts a battery terminal, a direct short will result in an instant heating, damage to equipment, and injury to personnel.</p> <p style="text-align: center;">CAUTION</p> <p>To reduce battery damage, check battery compartment for corrosion (greenish/white powder). Do not jerk or pull on battery cables during visual inspection.</p> <p>a. Release latches (63) and remove cover (60). Check battery compartment for damaged or missing batteries.</p> <p>b. Check for damaged or missing filler caps (61).</p> <p>c. Check for missing, broken, split, or frayed cables (64).</p> <p>d. Check for damaged terminal posts (62).</p> <p>e. Check for rust and corrosion.</p> <p>f. Check for cleanliness.</p> <p>g. Report any problems to Unit Maintenance.</p>	<p>a. One or more batteries are damaged or missing.</p> <p>b. One or more filler caps are damaged or missing.</p> <p>c. Cables are missing, broken, split, or frayed.</p> <p>d. Terminal posts are damaged.</p>

Table 1. Preventive Maintenance Checks and Services (PMCS) for M915A4 - Continued.

Item No.	Interval	Location	Procedure	Not Fully Mission Capable If:
		Item To Check/Service		
48 (Con't)	Weekly	Batteries	 <p style="text-align: right; margin-right: 100px;">402-053</p>	
49	Weekly	Spare Wheel and Tire	<p style="text-align: center;">WARNING</p> <p>Operating truck with an underinflated or defective tire may lead to tire failure and loss of steering control. Damage to equipment or injury to personnel may result.</p> <p>a. Check pressure in tire and adjust as required to achieve 105 psi (724 kPa).</p>	

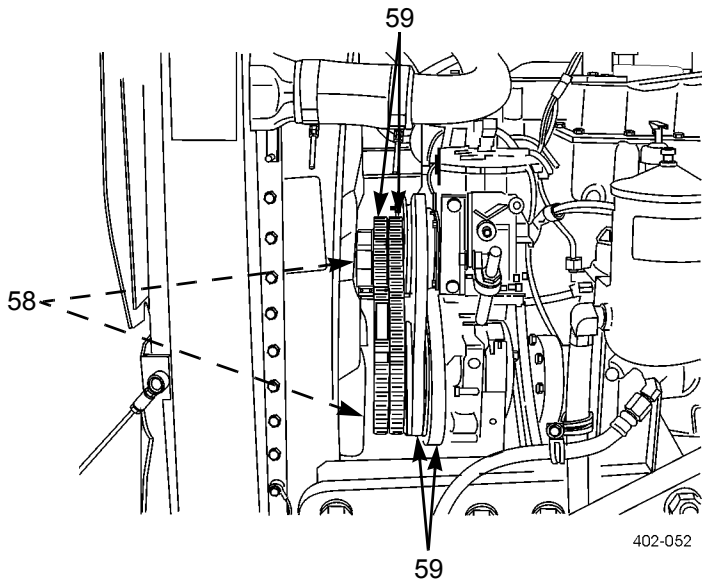
Table 1. Preventive Maintenance Checks and Services (PMCS) for M915A4 - Continued.

Item No.	Interval	Location	Procedure	Not Fully Mission Capable If:
		Item To Check/ Service		
49 (Con't)	Weekly	Spare Wheel and Tire	b. Check wheel for cracks, breaks, or bends.	b. Wheel is cracked, broken, or bent.
50	Weekly	Forward-Rear and Rear-Rear Wheels and Tires	<p style="text-align: center;">WARNING</p> <p>Operating truck with an underinflated or defective tire may lead to tire failure and loss of steering control. Damage to equipment or injury to personnel may result.</p>	
51	Weekly	Fifth Wheel	<p>a. Check pressure in tires and adjust as required:</p> <ul style="list-style-type: none"> • 100 psi (690 kPa) <p>b. Ensure all wheel stud lug nuts are tight, using wheel stud lug nut wrench and handle.</p> <p>c. Check wheel for cracks, breaks, or bends.</p>	<p>b. Two or more wheel studs are missing or lug nuts are loose.</p> <p>c. Wheel is cracked, broken, or bent.</p>
		UNDER VEHICLE	Lubricate fifth wheel in accordance with WP 0017 00.	
52	Weekly	Steering Components	Check front axle steering components for cracks, breaks, loose connections, or other damage.	Any steering component is cracked, broken, or loose.
53	Weekly	Axle Breathers	<p style="text-align: center;">NOTE</p> <p>Perform the following service at all axles except the front axle.</p> <p>Without removing breather vent (65), check for a clogged vent. Clean with detergent (Item 4, WP 0021 00) as required to remove dirt and grease.</p>	

Table 1. Preventive Maintenance Checks and Services (PMCS) for M915A4 - Continued.

Item No.	Interval	Location	Procedure	Not Fully Mission Capable If:
		Item To Check/Service		
53 (Con't)	Weekly	Axle Breathers		

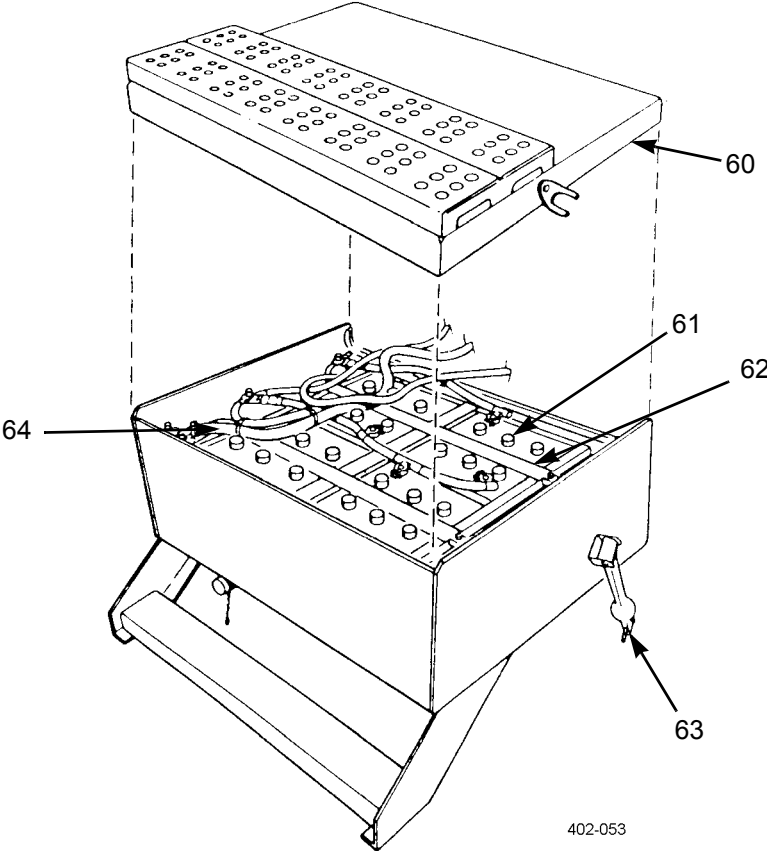
Table 1. Preventive Maintenance Checks and Services (PMCS) for M915A4 - Continued.

Item No.	Interval	Location	Procedure	Not Fully Mission Capable If:
		Item To Check/Service		
54	Weekly	Brake Chambers	<p>NOTE</p> <p>Perform the following check at all axles.</p> <p>Check brake chamber service pushrod to see if stroke alert indicator (orange band) (66) is visible.</p>	Stroke alert indicator is visible.
 <p style="text-align: right;">402-036</p>				
55	Weekly	<p>REAR AND RIGHT SIDE</p> <p>Pintle Hook</p>	<p>Check pintle hook (67) for looseness, damaged locking mechanism, and presence of cotter pin. Lubricate at all four grease fittings (68) (WP 0017 00), if pintle hook does not rotate freely by hand.</p>	

Table 1. Preventive Maintenance Checks and Services (PMCS) for M915A4 - Continued.

Item No.	Interval	Location	Procedure	Not Fully Mission Capable If:
		Item To Check/Service		
55 (Con't)	Weekly	Pintle Hook		
				
56	Weekly	Rear-Rear and Forward-Rear Wheels and Tires	<p style="text-align: center;">WARNING</p> <p>Operating truck with an underinflated or defective tire may lead to tire failure and loss of steering control. Damage to equipment or injury to personnel may result.</p> <ol style="list-style-type: none"> a. Check pressure in tires and adjust as required: 100 psi (690 kPa) b. Ensure all wheel stud lug nuts are tight, using wheel stud lug nut wrench and handle c. Check wheel for cracks, breaks, or bends. 	<ol style="list-style-type: none"> b. Two or more wheel studs are missing or lug nuts are loose. c. Wheel is cracked, broken, or bent.

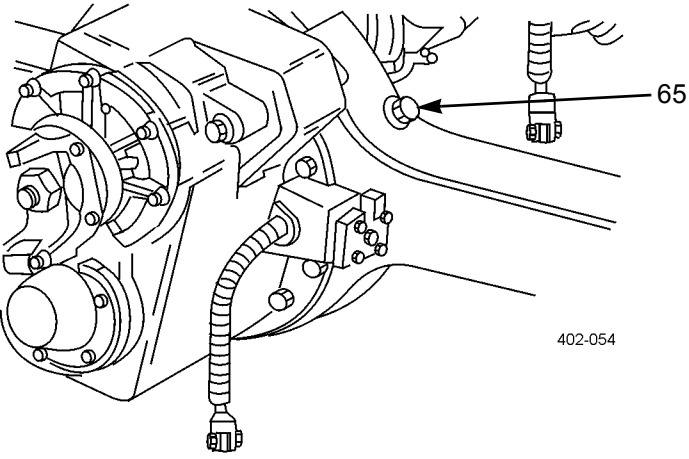
Table 1. Preventive Maintenance Checks and Services (PMCS) for M915A4 - Continued.

Item No.	Interval	Location	Procedure	Not Fully Mission Capable If:
		Item To Check/ Service		
57	Weekly	Front Wheel and Tire	<p>WARNING</p> <p>Operating truck with an underinflated or defective tire may lead to tire failure and loss of steering control. Damage to equipment or injury to personnel may result.</p> <p>a. Check pressure in tires and adjust as required: 105 psi (724 kPa)</p> <p>b. Ensure all wheel stud lug nuts are tight, using wheel stud lug nut wrench and handle.</p> <p>c. Check wheel for cracks, breaks, or bends.</p>	<p>b. Two or more wheel studs are missing or lug nuts are loose</p> <p>c. Wheel is cracked, broken, or bent.</p>
		CAB INTERIOR		
58	Weekly	Doors and Windows	Check operation and general condition of cab doors and windows.	
		OVER-ALL VEHICLE		
59	Monthly	Undercarriage, Frame, Cab, and Propeller Shafts	<p>a. Check for obvious damage to frame and undercarriage.</p> <p>b. Check propeller shafts and U-joints for loose or broken bolts and nuts.</p>	<p>a. Any loose or broken frame side rails, crossmembers, broken welds, or broken bolts are found.</p> <p>b. Mounting bolts and nuts are loose or missing.</p>
60	Monthly	Air System	<p>a. Check all air lines, fittings, and valves for looseness or damage. Ensure vent hole (69) in each dummy coupling is free of dirt or debris.</p>	Any air lines, fittings, or valves are loose or damaged. Any dummy coupling vent hole is clogged.

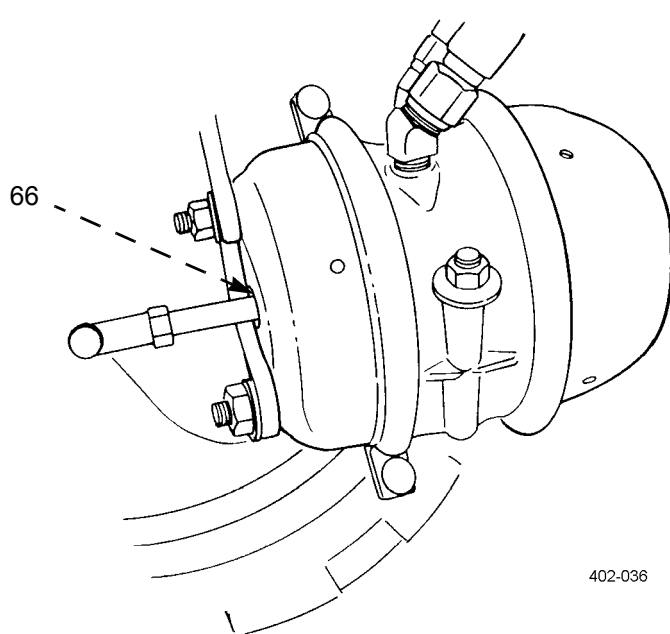
Table 1. Preventive Maintenance Checks and Services (PMCS) for M915A4 - Continued.

Item No.	Interval	Location	Procedure	Not Fully Mission Capable If:
		Item To Check/Service		
60 (Con't)	Monthly	Air System	 <p style="text-align: right;">402-088</p> <p>b. On each air tank, press rubber pin (70) on automatic drain valve to release air.</p>  <p style="text-align: right;">402-045</p> <p style="text-align: center;">70</p>	

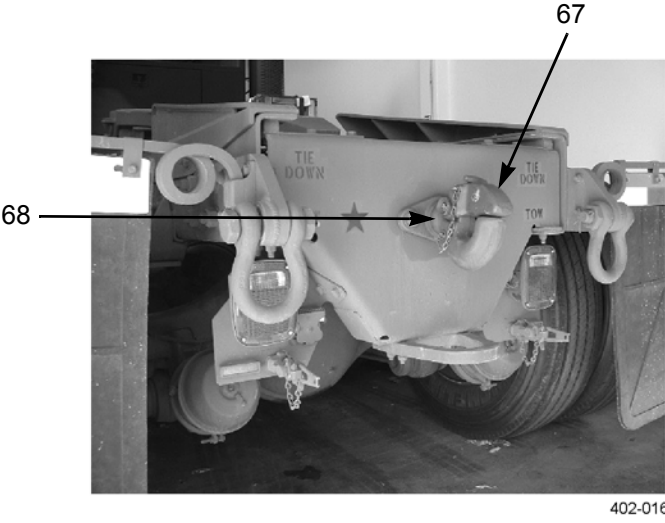
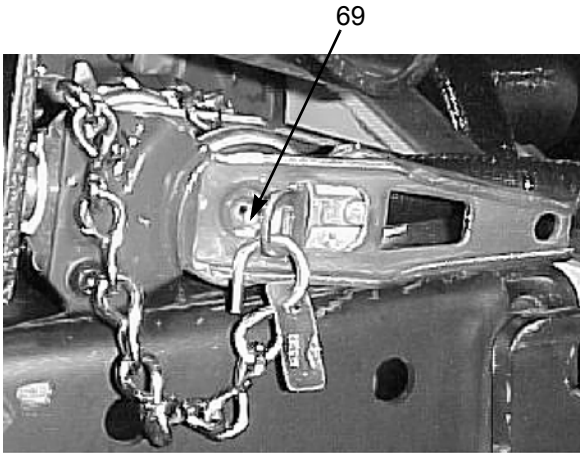
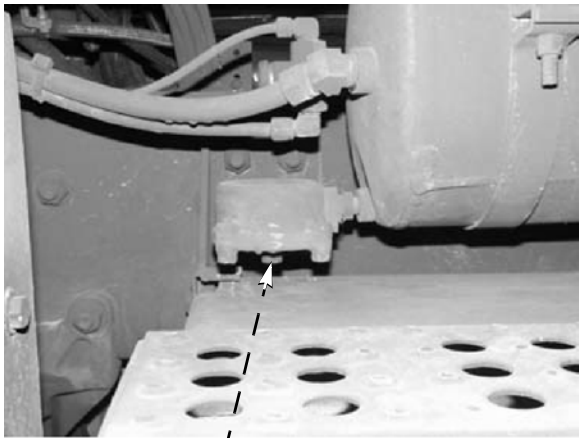
TM 9-2320-303-10

Table 1. Preventive Maintenance Checks and Services (PMCS) for M915A4 - Continued.

Item No.	Interval	Location	Procedure	Not Fully Mission Capable If:
		Item To Check/ Service		
61	Monthly	Air Conditioner	Check air conditioner operation. Operate for at least five minutes to help prevent drying and cracking of tubing seals and reduce refrigerant leaks in the system.	
62	Monthly	Fire Extinguisher	Remove fire extinguisher from bracket and shake vigorously to loosen powdered agent that settles to the bottom.	

END OF WORK PACKAGE

WARNING

Compressed air used for cleaning or drying purposes, or for clearing restrictions, should never exceed 30 psi (207 kPa). Wear protective clothing (goggles/shield, gloves, etc.) and use caution to avoid injury to personnel.

CAUTION

DO NOT use high pressure water to clean inside of cab or engine compartment. DO NOT direct spray at ANY electrical components. Damage to electrical system may result.

1. **Exterior.**

While cleaning vehicle, look closely for evidence of rust or corrosion, bare metal, or other exterior damage. If any problems are found, notify Unit Maintenance to treat affected areas.

2. **Interior.**

- (1) Remove loose dust and dirt from cab interior components.
- (2) Clean upholstery and seat belts using a mild solution of warm water and soap (never use solvents or abrasives). Wipe all washed areas dry.

3. **Refueling.****WARNING**

- DO NOT smoke or permit any open flame in area of truck while you are servicing diesel fuel system. Be sure hose nozzle is grounded against filler tube during refueling to prevent static electricity. Failure to follow this warning may result in injury to personnel or equipment damage.
- Auxiliary arctic heater, if equipped, must be switched to OFF while refueling.

NOTE

- Place portable fire extinguisher within reach prior to refueling.
 - DO NOT overfill fuel tank.
 - If fuel starts foaming from fuel tank, stop immediately to avoid fuel spillage.
- a. Shut down engine.
 - b. Place master switch in OFF position.
 - c. Ensure that auxiliary arctic heater, if equipped, is switched to OFF.
 - d. Wipe off dirt on and around fuel filler cap (1).
 - e. Remove filler cap (1) by rotating cap counterclockwise.
 - f. Fill tank (2) to holes [approximately 3 in. (7.6 cm)] in filler neck.
 - g. Install filler cap (1) by rotating cap clockwise as far as it will go.

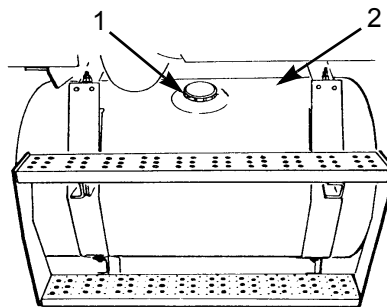

402-050

END OF WORK PACKAGE

WHEEL AND TIRE MAINTENANCE INSTRUCTIONS

1. Remove pneumatic hose (1) with gage from BII storage box.

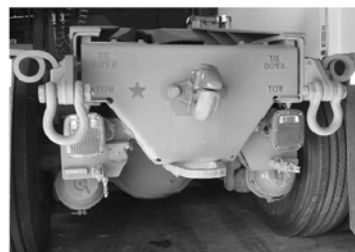
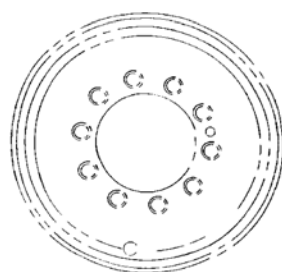
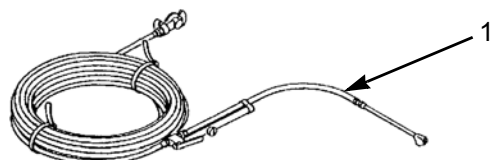

402-067

2. Remove dummy coupling (2). Connect pneumatic hose (1) to emergency gladhand (red) (3) on left rear of vehicle.

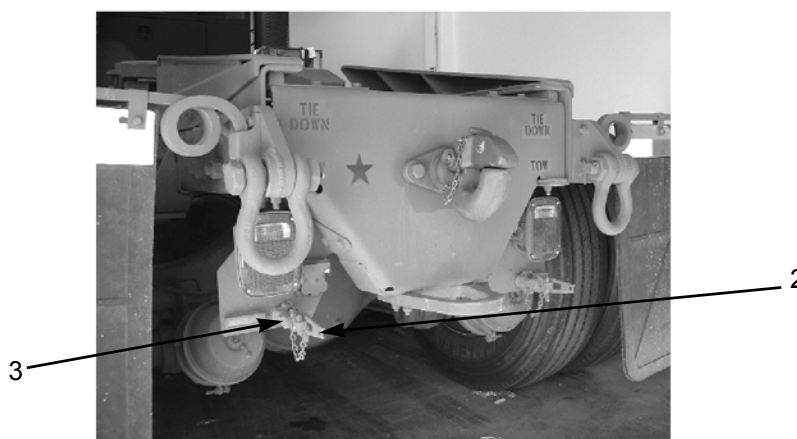

402-016

WHEEL AND TIRE MAINTENANCE INSTRUCTIONS - CONTINUED

3. Start engine. Push in (ON) trailer air supply control valve.
4. Rotate air flow valve lever (4) to vertical position.
5. Remove valve stem cap (5) and connect pneumatic hose (1) to valve stem (6).
6. Add air until desired pressure is reached.

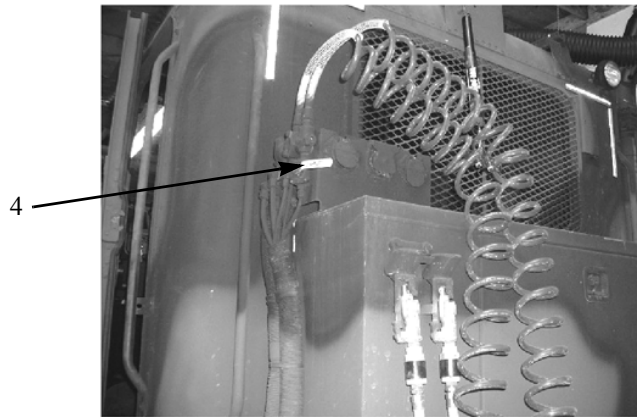

402-011

7. Remove pneumatic hose (1) from valve stem (6) and install valve stem cap (5).
8. Rotate air flow valve lever (4) to horizontal position.
9. Pull out (OFF) trailer air supply control valve. Shut down engine (WP 0005 00).
10. Disconnect pneumatic hose (1) from emergency gladhand (3) and return to stowage in BII storage box.
11. Install dummy coupling (2) on emergency gladhand (3).

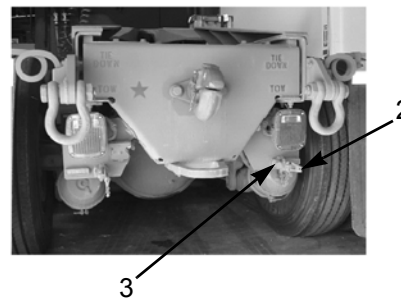
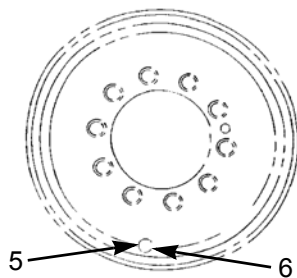
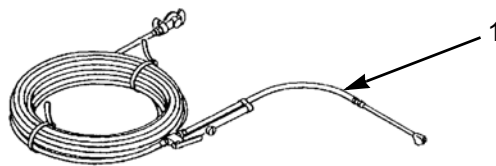

402-067

OPERATION OF SPARE WHEEL AND TIRE ASSEMBLY CARRIER**WARNING**

Use caution when lifting or handling wheel and tire assembly. It is heavy and could cause injury if improperly lifted or if it falls on you.

1. **Remove Spare Wheel and Tire Assembly from Carrier.**
 - a. Ensure pawl (2) engages gear shaft (1) and remove nuts (4).
 - b. Turn gear shaft (1) clockwise slightly and disengage pawl (2) from gear shaft. Swing pawl out of way.
 - c. Slowly rotate gear shaft (1) counterclockwise one notch.

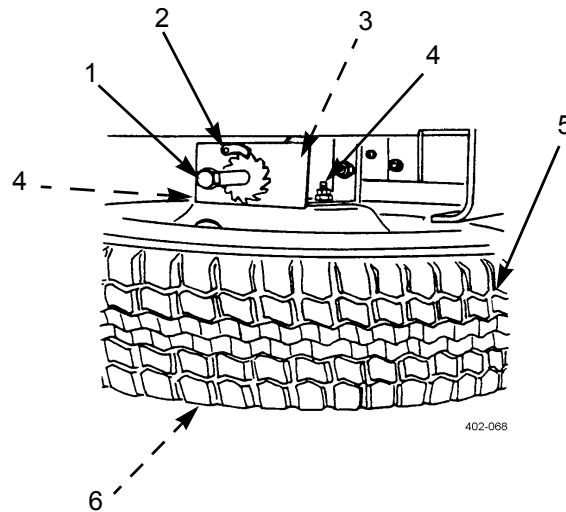

- d. Support spare wheel and tire assembly (5) and remove wheel clamp plate (6).

OPERATION OF SPARE WHEEL AND TIRE ASSEMBLY CARRIER - CONTINUED**NOTE**

Keep tire in upright position after removal so it can be rolled into position. DO NOT allow tire to fall or lay flat on ground. If tire falls or is laid flat on ground, assistance will be required to raise tire to upright position.

- (3) Repeat steps (2) and (3) until spare wheel and tire assembly (5) is lowered to ground.

2. **Install Spare Wheel and Tire Assembly on Carrier.**

- a. Secure hoist cable (3) by inserting wheel clamp plate (6) through wheel opening.
- b. Turn gear shaft (1) clockwise until spare wheel and tire assembly (5) is raised to stowed position.
- c. Engage pawl (2) on gear shaft (1).
- d. Install nuts (4).

WHEEL AND TIRE ASSEMBLY REPLACEMENT**NOTE**

When changing tires, DO NOT substitute type or size tire unless all tires on the vehicle can be converted. Keep all tires the same size and type.

1. **Placement of Jack.**

- a. For front tire replacement, place jack (4) so jack ram (3) is under first small leaf spring (1) just forward of axle (2).

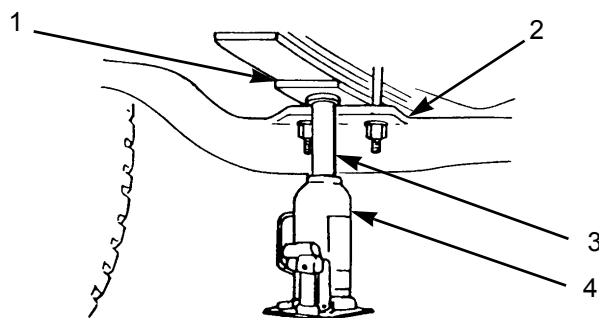

402-069

- b. For rear tire replacement, place jack (4) so jack ram (3) is under equalizing beam (6) inboard of equalizing beam end adapter (5).

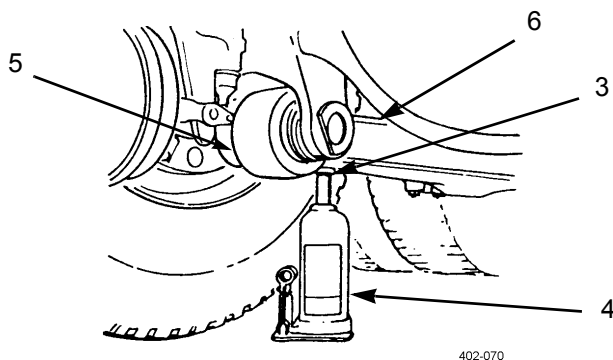
WHEEL AND TIRE ASSEMBLY REPLACEMENT- CONTINUED**2. Remove Wheel and Tire Assembly.**

- a. Block wheels.
- b. Remove spare wheel and tire assembly from carrier.

NOTE

- If replacing inner rear tire, loosen both outer and inner wheel nuts.
 - Wheel nuts on left side of vehicle are left hand threads (turn right to loosen, turn left to tighten). Wheel nuts on right side of vehicle are right hand threads (turn left to loosen, turn right to tighten).
- c. Loosen wheel nuts on wheel to be removed.
 - d. Place jack in position.

WARNING

Hydraulic jack is intended only for lifting truck, not for supporting vehicle to perform maintenance. Do not get under truck after it is raised unless it is properly supported with blocks or jackstands. Failure to observe this warning may result in death or injury to personnel.

- e. Raise jack until tire(s) clears ground.

WHEEL AND TIRE ASSEMBLY REPLACEMENT- CONTINUED**WARNING**

Use caution when lifting or handling wheel and tire assembly. It is heavy and could cause injury if improperly lifted or if it falls on you.

NOTE

Keep tire in upright position after removal so it can be rolled into position. DO NOT allow tire to fall or lay flat on ground. If tire falls or is laid flat on ground, assistance will be required to raise tire to upright position.

- f. For front or outer rear tire, remove wheel nuts and wheel and tire assembly.
 - g. If replacing inner rear tire, remove wheel nuts and wheel and tire assembly.
3. **Install Wheel and Tire Assembly.**
- a. Inflate spare tire to proper pressure.

WARNING

Use caution when lifting or handling wheel and tire assembly. It is heavy and could cause injury if improperly lifted or if it falls on you.

NOTE

- Wheel nuts on left side of vehicle are left hand threads (turn right to loosen, turn left to tighten). Wheel nuts on right side of vehicle are right hand threads (turn left to loosen, turn right to tighten).
 - Valve stems on inner and outer rear tires should be positioned 180° apart.
- b. If replacing inner rear tire, position wheel and tire assembly on wheel hub and install and handtighten wheel nuts.
 - c. For front or outer rear tire, position wheel and tire assembly on wheel hub and install and handtighten wheel nuts.
 - d. Lower and remove jack.

WHEEL AND TIRE ASSEMBLY REPLACEMENT- CONTINUED**WARNING**

- Whenever inner and/or outer wheel lug nuts require tightening or a wheel has been removed and replaced, lug nuts must be torqued to the required torque. Failure to follow this warning may result in serious injury to personnel and damage to equipment.
 - Tighten wheel nuts with wheel wrench. After 25 miles (40 km), retighten wheel nuts. Within next 75 miles (121 km), have Unit Maintenance torque wheel nuts to proper torque.
 - Tightening pattern is identical for all wheel assemblies.
- e. For front or outer rear tire, tighten wheel nuts according to tightening pattern.

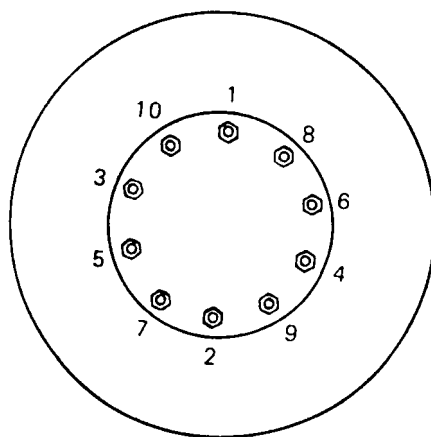

402-071

WHEEL NUT TIGHTENING PATTERN

- f. If replacing inner rear tire, alternately tighten inner wheel nuts by removing outer wheel nut according to tightening pattern and tighten inner wheel nut. After tightening inner wheel nut, reinstall outer wheel nut and tighten according to tightening pattern.
- g. Notify Unit Maintenance as soon as possible to apply proper torque.
- h. Stow defective tire in spare wheel and tire carrier and have it replaced or repaired as soon as possible.
- i. Remove wheel blocks.

END OF WORK PACKAGE

WARNING

- To avoid eye injury, eye protection is required when working around batteries. Do not smoke, use open flame, make sparks, or create other ignition sources around batteries. If a battery is giving off gases, it can explode and cause injury to personnel. Remove all jewelry such as rings, ID tags, watches, and bracelets. If jewelry or a tool contacts a battery terminal, a direct short will result in instant heating, damage to equipment, and injury to personnel.
 - Sulfuric acid contained in batteries can cause serious burns. If battery corrosion or electrolyte makes contact with skin, eyes, or clothing, take immediate action to stop the corrosive burning effects. Failure to follow these procedures may result in death or serious injury to personnel.
 - (a) Eyes. Flush with cold water for no less than 15 minutes and seek medical attention immediately.
 - (b) Skin. Flush with large amounts of cold water until all acid is removed. Seek medical attention as required.
 - (c) Internal. If corrosion or electrolyte is ingested, drink large amounts of water or milk. Follow with milk of magnesia, beaten egg, or vegetable oil. Seek medical attention immediately.
 - (d) Clothing/Equipment. Wash area with large amounts of cold water. Neutralize acid with baking soda or household ammonia.
1. Unfasten two latches (3) and slide battery box cover (2) outboard from battery box (4).
 2. Slide battery box cover (2) on battery box (4) with step (1) outboard. Fasten two latches (3).

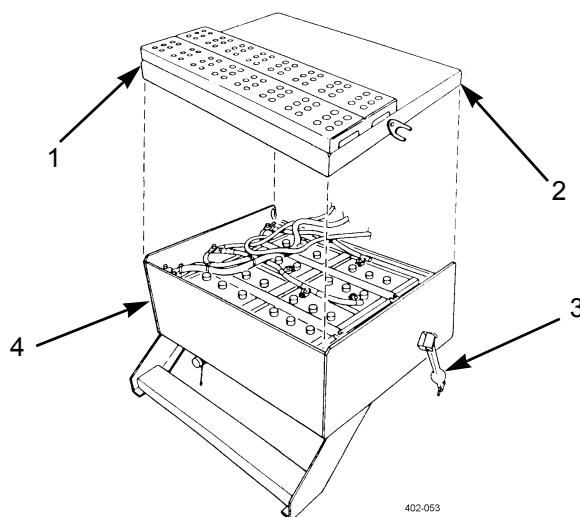
**END OF WORK PACKAGE**

REAR WINDOW GUARD REPLACEMENT

0016 00

1. Remove four thumb screws (2) and guard (3) from cab (1).
2. Position guard (3) on cab (1) and install four thumb screws (2).

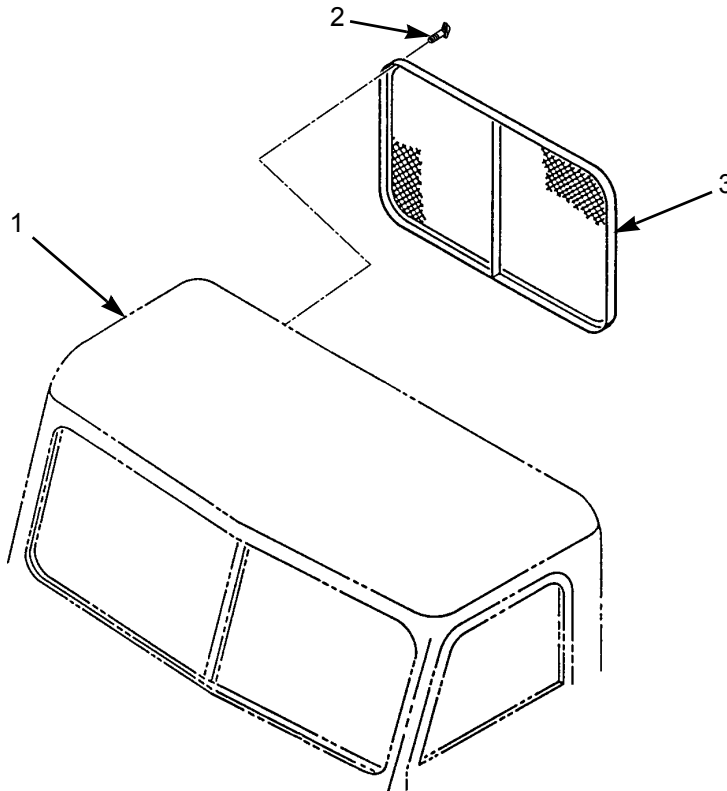

371-406

END OF WORK PACKAGE

GENERAL**NOTE**

These instructions are mandatory.

- a. The M915A4 must receive lubrication with approved lubricants at recommended intervals in order to be mission-ready at all times.
- b. The Lubrication Chart shows lubrication points, items to be lubricated, the required lubricants, and recommended intervals for lubrication by the operator/crew. Any special lubrication instructions required for specific components are contained in the NOTES section of the chart.
- c. The KEY and CHARTs A through D provide information needed to select the proper lubricant for various temperature ranges and uses, and identify the interval.
- d. Recommended intervals are based on normal conditions of operation, temperature, and humidity. When operating under extreme conditions, lubricants should always be changed more frequently. When in doubt, notify your supervisor.

SPECIFIC LUBRICATION INSTRUCTIONS

- a. Keep all lubricants in a closed container and store in a clean, dry place away from extreme heat. Keep container covers clean and do not allow dust, dirt, or other foreign material to mix with lubricants. Keep lubrication equipment clean and ready for use.
- b. Maintain a record of lubrication performed and report any problems noted during lubrication. Refer to DA Pam 738-750 for maintenance forms and procedures to record and report any findings.
- c. Keep all external parts of equipment not requiring lubrication free of lubricants. After lubrication, wipe off excess lubricant to prevent accumulation of foreign matter.
- d. Refer to FM 9-207 for lubrication instructions in cold weather.

LUBRICATION CHART

TRUCK, TRACTOR, LINE HAUL: 52,000 GVWR, 6 X 4, M915A4 (NSN 2520-01-458-1207)

This Lubrication Chart is for the operator/crew (C). Lubrication intervals (on-condition or hard time) are based on normal operation. Lubricate more during constant use and less during inactive periods. Use correct grade of lubricant for seasonal temperature expected.

For equipment under manufacturer's warranty, hard time oil service intervals shall be followed. Intervals shall be shortened if lubricants are known to be contaminated or if operation is under adverse conditions (e.g., longer than usual operating hours, extended idling periods, extreme dust, etc.).

Clean area around lubrication points with detergent (Item 4, WP 0021 00) or equivalent before lubricating equipment. After lubrication, wipe off excess lubricant to prevent accumulation of foreign matter.

Dashed leader line indicates lubrication on both sides of vehicle.

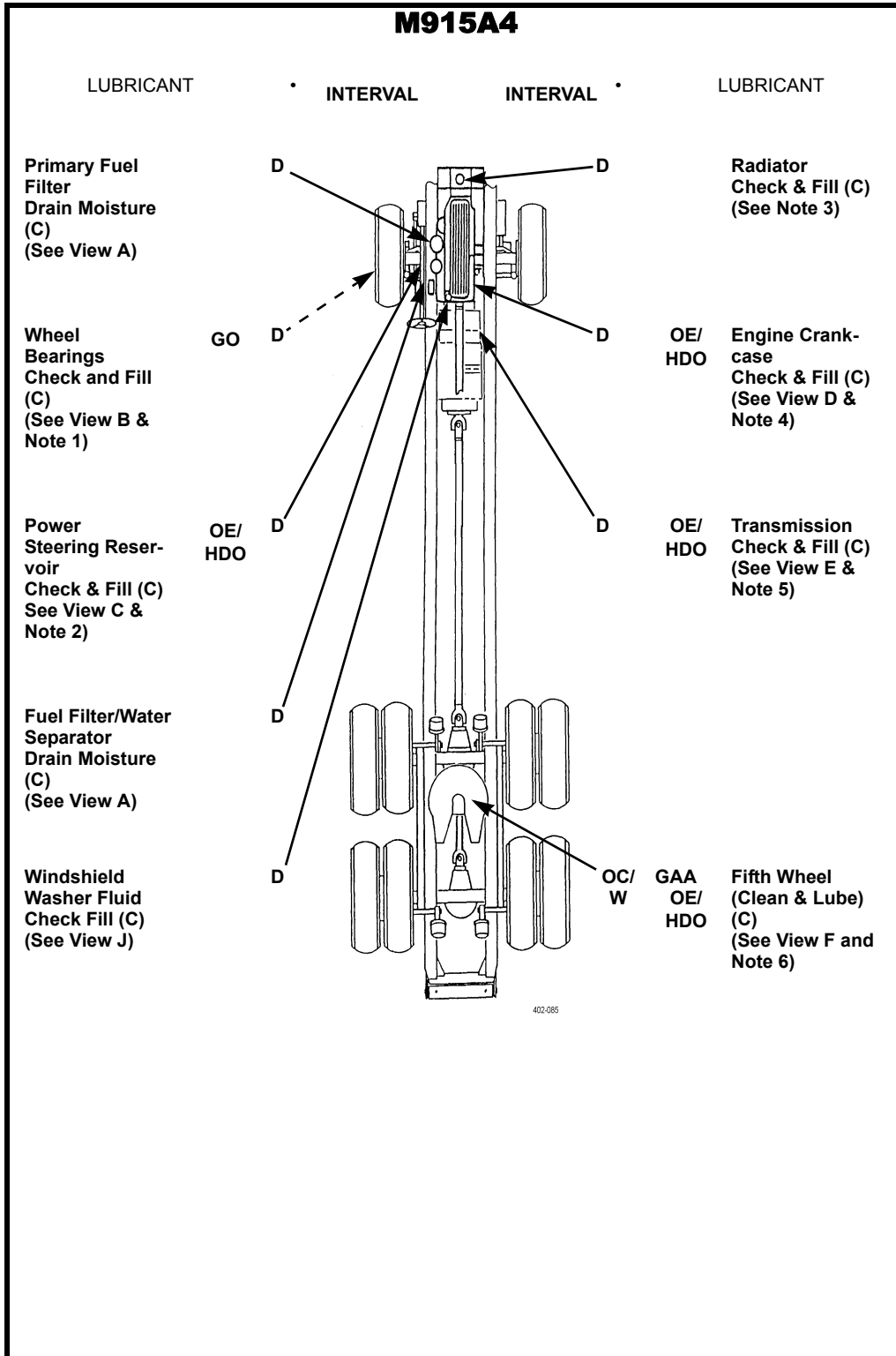

TM 9-2320-303-10

- KEY -

Lubricant/ Component	Refill Capacity	Expected Temperatures*			Intervals
		+6°F to +122°F (-14°C to +50°C)	-4°F to +50°F (-20°C to +10°C)	-67°F to +32°F (-55°C to 0°C)	
OE/HDO (MIL-L-2104) Lubricating Oil, ICE, Tactical					D - Daily W - Weekly OC - On Condition
OEA (MIL-L-46167) Lubricating Oil, ICE, Arctic					
Engine Crankcase w/ Filters	46 Qt (43.5 L)	See Chart A			
Transmission	51 Qt (48 L)	See Chart B			
Power Steering Reservoir	2 Qt (1.9 L)	See Chart A			
Oil Can Points	As Req'd	See Chart A			
GO (MIL-L-2105) Lubricating Oil, Gear, Multipurpose					
Front Axle Wheel Bearings	As Req'd	See Chart C			
GAA (MIL-G-10924) Grease, Automotive and Artillery					
Fifth Wheel	As Req'd	All Temperatures			
ANTIFREEZE (MIL-A-11755) Ethylene Glycol, Inhibited, Heavy Duty					
Antifreeze (MIL-A-11755) Ethylene Glycol, Arctic Grade					
Engine Radiator	17.25 Gal. (65.3 L)	See Chart D			

* For Arctic Operation, refer to FM 9-207.

Table 1. CHART A-ENGINE, POWER STEERING, AND OIL CAN POINTS

Lubricant	EXPECTED TEMPERATURES																			
	°F	-70	-60	-50	-40	-30	-20	-10	0	+10	+20	+30	+40	+50	+60	+70	+80	+90	+100	+120
	°C	-57	-51	-46	-40	-34	-29	-23	-18	-12	-7	-1	+4	+10	+16	+21	+27	+32	+38	+49
OE/HDO (MIL-L-2104)	Lubricating Oil, ICE, Tactical																			
OEA (MIL-L-46167)	Lubricating Oil, ICE, Arctic																			
OE/HDO-15/40 (0 - 1236)																				
OE/HDO-10* (0 - 237)																				
OE/HDO-30 (0 - 238)																				
OE/HDO-40 (N/A)																				
OEA * (0 - 183)																				

*If OEA lubricant is required to meet the low expected-temperature range, OEA lubricant is to be used in lieu of OE/HDO-10 lubricant for all expected temperatures where OE/HDO-10 is specified.

Table 2. CHART B-TRANSMISSION

Lubricant	EXPECTED TEMPERATURES																			
	°F	-70	-60	-50	-40	-30	-20	-10	0	+10	+20	+30	+40	+50	+60	+70	+80	+90	+100	+120
	°C	-57	-51	-46	-40	-34	-29	-23	-18	-12	-7	-1	+4	+10	+16	+21	+27	+32	+38	+49
OE/HDO (MIL-L-2104)	Lubricating Oil, ICE, Tactical																			
OEA (MIL-L-46167)	Lubricating Oil, ICE, Arctic																			
OE/HDO-15/40 (0 - 1236)																				
OE/HDO-10 * (0 - 237)																				
OEA * (0 - 183)																				

*If OEA lubricant is required to meet the low expected-temperature range, OEA lubricant is to be used in lieu of OE/HDO-15/40 lubricant for all expected temperatures where OE/HDO-10 and OE/HDO-15/40 are specified.

Table 3. CHART C-FRONT AXLE WHEEL BEARINGS

Lubricant	EXPECTED TEMPERATURES																			
	°F	-70	-60	-50	-40	-30	-20	-10	0	+10	+20	+30	+40	+50	+60	+70	+80	+90	+100	+120
	°C	-57	-51	-46	-40	-34	-29	-23	-18	-12	-7	-1	+4	+10	+16	+21	+27	+32	+38	+49
GO (MIL-PRF-2105)	Lubricating Oil, Gear, Multipurpose																			
GO-75 (0 - 186)																				
GO-80/90 (0 - 226)																				
GO-85/140 (0 - 228)																				

Table 4. CHART D-ANTIFREEZE

Lubricant	EXPECTED TEMPERATURES																			
	°F	-90	-80	-70	-60	-50	-40	-30	-20	-10	0	+10	+20	+30	+40	+50	+60	+70	+80	+90
	°C	-68	-62	-57	-51	-46	-40	-34	-29	-23	-18	-12	-7	-1	+4	+10	+16	+21	+27	+32
MIL-A-46153	Antifreeze, Ethylene Glycol, Inhibited, Heavy Duty																			
MIL-A-11755	Antifreeze, Arctic Grade																			
MIL-A-46153																				
MIL-A-11755																				

VIEW A—FUEL FILTER/WATER SEPARATOR

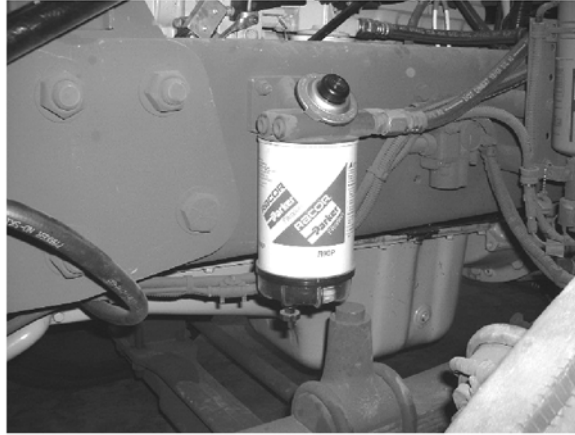

402-015

VIEW B—FRONT AXLE WHEEL BEARINGS

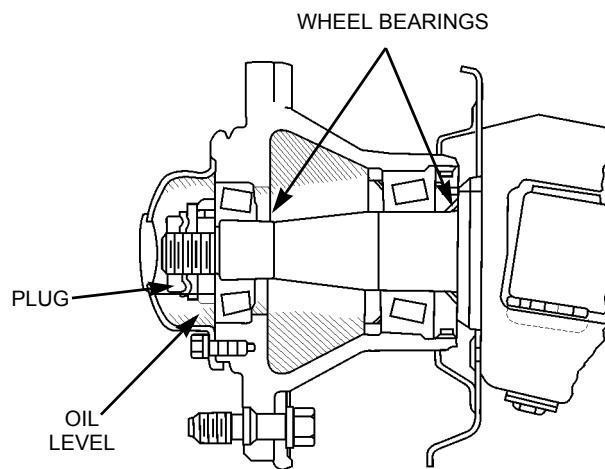

402-047

VIEW C—POWER STEERING RESERVOIR

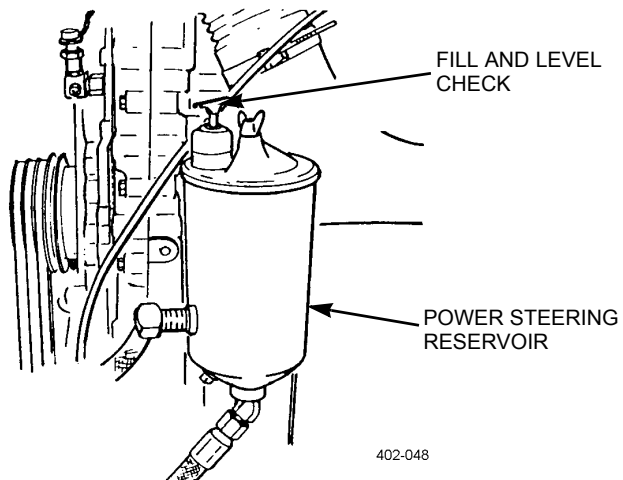

VIEW D—ENGINE CRANKCASE

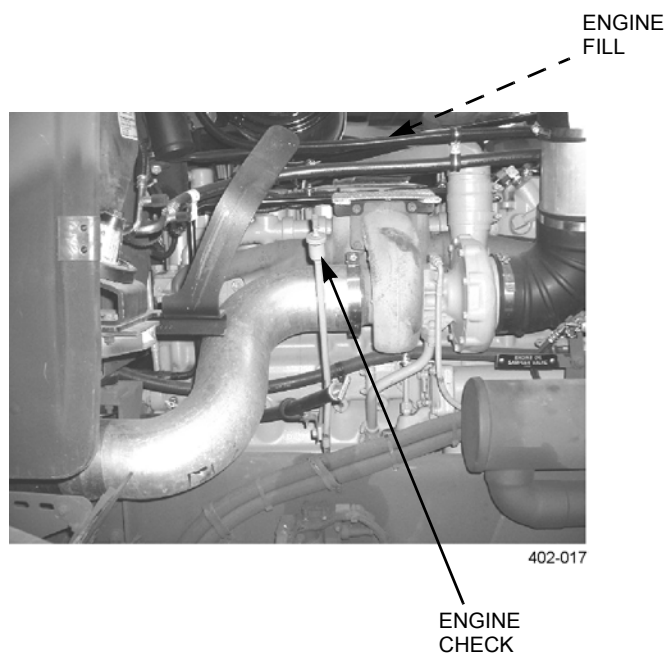

VIEW E—TRANSMISSION

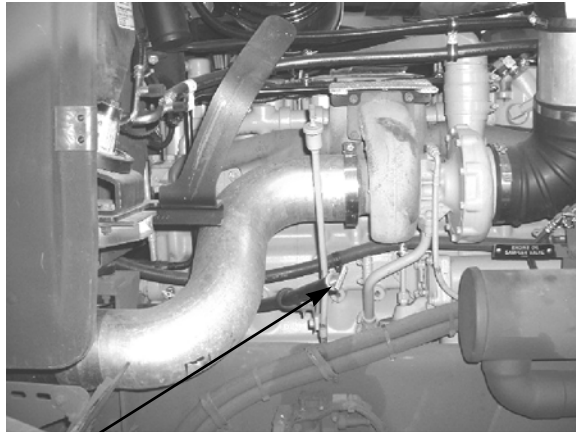

402-017

TRANSMISSION
CHECK AND FILL

VIEW F—FIFTH WHEEL

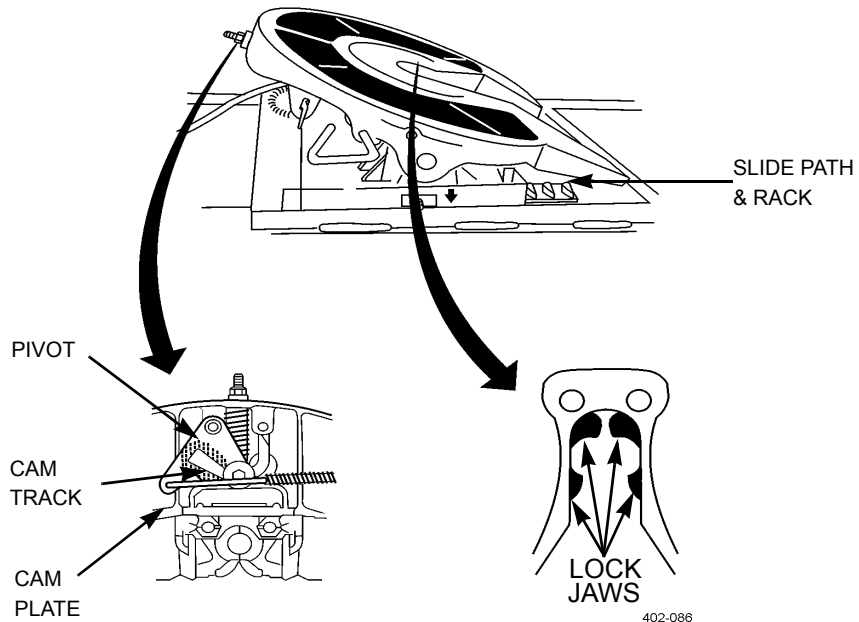

402-086

VIEW G—CAB DOOR

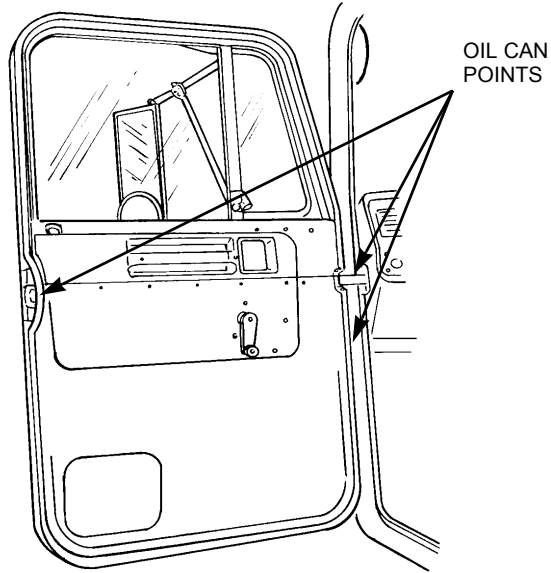

402-035

VIEW H—SEATS

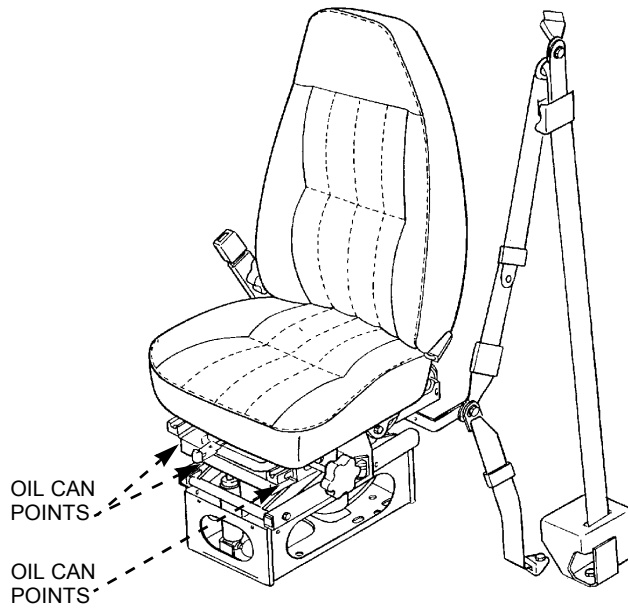

402-034

VIEW I—SPARE WHEEL AND TIRE CARRIER

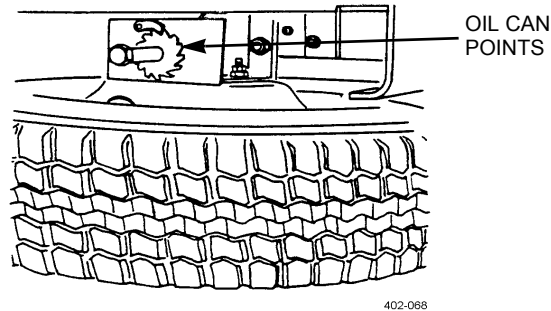

VIEW J—WINDSHIELD WASHER FLUID

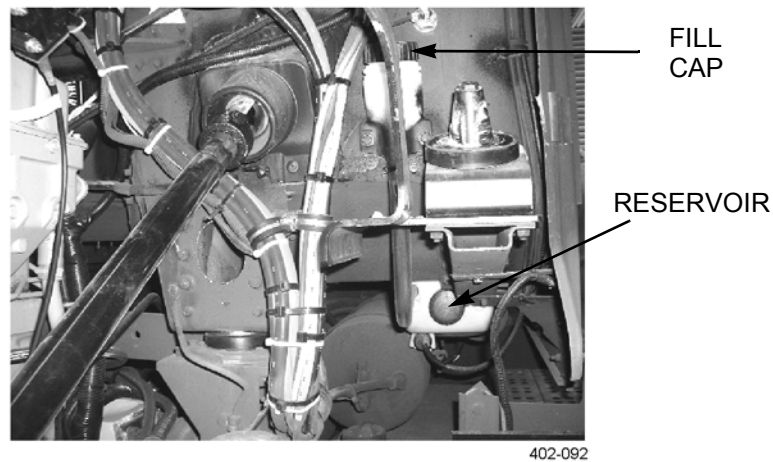

NOTES:

1. **FRONT AXLE WHEEL BEARINGS.** Daily, check that level of gear lubricating oil is visible in sight glass. If oil is not visible, remove rubber plug and add GO until level is even with plug opening. Install rubber plug.
2. **POWER STEERING RESERVOIR.** Daily, with engine running and fluid at operating temperature, remove dipstick from reservoir and check level of lubricating oil on dipstick. Add OE/HDO to bring level above the ADD mark on dipstick.

3. **RADIATOR.**

WARNING

Let radiator cool before removing cap. Remove cap in two steps. First place thick cloth over cap and slowly turn cap counterclockwise to its first stop; pause, and allow pressure to escape from cooling system. Then turn cap further counterclockwise until you can remove it. Failure to follow this procedure can result in serious burns.

Daily, with engine cool, remove radiator cap. Check level of coolant in radiator. Coolant must be within 2 1/2 in. (6.4 cm) below filler neck. Add coolant to correct level. Install radiator cap.

4. **ENGINE CRANKCASE.** Daily, check level of lubricating oil. Wait 10 minutes after shutting down engine to allow oil to drain back into crankcase. To ensure an accurate reading, vehicle must be parked on level ground. Safe operating level is between ADD and FULL marks on dipstick. As required, add OE/HDO through filler opening. DO NOT overfill.

5. **TRANSMISSION.**

CAUTION

Transmission must not be operated for extended periods of time until a Hot Check has verified proper fluid level. Transmission damage can result from extended operation at improper fluid level conditions.

COLD OIL CHECK (COLD RUN BAND). Run engine for one minute at idle speed. Idle engine in Neutral (N) until transmission reaches 60°-120°F (16°-49°C). Shift transmission to Drive (D), then to Reverse (R), then return to N. Remove dipstick from oil filler tube, wipe clean, and check oil level. Oil registering in the COLD RUN band indicates a sufficient quantity of oil to safely operate the transmission until temperature reaches 160°-200°F (71°-93°C). If fluid level is not within COLD RUN band, add or drain fluid, as required, to bring level within the band. When temperature reaches 160°-200°F (71°-93°C), a hot oil check MUST be performed.

HOT OIL CHECK (HOT RUN BAND). Be sure temperature has reached 160°-200°F (71°-93°C). With truck on level ground, engine idling, and transmission in Neutral (N), remove dipstick from oil filler tube, wipe clean, and check oil level. If oil registers in the HOT RUN band, quantity of oil in transmission is safe for operating the vehicle. If it registers on or below the bottom line of the HOT RUN band, add the required amount of oil to bring oil level to the middle of the HOT RUN band.

6. **FIFTH WHEEL.** Weekly or on-condition, apply GAA to lock jaws and front of throat. Lubricate the cam track, pivot, rack, and slide path with light oil or diesel oil.

7. **OIL CAN POINTS.** On-condition or weekly, lubricate sparingly with OE/HDO: door hinges and latches (View G); driver and passenger seat adjusters and sliding tracks (View H); and spare wheel and tire carrier ratchet gear shaft (View I).

END OF WORK PACKAGE

TM 9-2320-303-10

CHAPTER 5
SUPPORTING INFORMATION

REFERENCES

0018 00

SCOPE

This work package lists all forms, field manuals, technical manuals, and other publications referenced in this manual and which apply to the operation of the M915A4 truck tractor.

PUBLICATION INDEXES

The following indexes should be consulted frequently for latest changes or revisions and for new publications relating to material covered in this technical manual.

Consolidated Index of Army Publications and Blank Forms	DA Pam 25-30
Functional User's Manual for the Army Maintenance Management System	DA Pam 738-750
U.S. Army Equipment Index of Modification Work Orders	DA Pam 750-10

FORMS

Refer to DA Pam 738-750, *The Army Maintenance Management System (TAMMS)*, for instructions on the use of maintenance forms.

Equipment Inspection and Maintenance Worksheet	DA Form 2404
Product Quality Deficiency Report	SF Form 368
Recommended Changes to Equipment Technical Publications	DA Form 2028-2
Recommended Changes to Publications and Blank Forms	DA Form 2028

FIELD MANUALS

Basic Cold Weather Manual	FM 31-70
Camouflage	FM 5-20
Desert Operations	FM 90-3
Driver Selection/Training	FM 21-300
First Aid Manual	FM 4-25.11
Manual for the Wheeled Vehicle Driver	FM 21-305
NBC Contamination Avoidance	FM 3-3
NBC Decontamination	FM 3-5
NBC Protection	FM 3-4
Northern Operations	FM 31-71
Operations and Maintenance of Ordnance Material in Cold Weather	FM 9-207
Recovery and Battlefield Damage Assessment and Repair	FM 9-43-2
Rigging Techniques, Procedures, and Applications	FM 5-125

REFERENCES - CONTINUED

0018 00

TECHNICAL MANUALS

- Operator's, Organizational, Direct Support and General Support
Maintenance Manual for Lead-acid Storage Batteries TM 9-6140-200-14
- Operator's, Unit, Direct Support and General Support Maintenance
Manual for Care, Maintenance, Repair and Inspection of
Pneumatic Tires and Inner Tubes TM 9-2620-200-14
- Operator's, Unit, Direct Support, and General Support
Maintenance Manual (Including Repair Parts and Special
Tools List) for Semitrailer, Flatbed: Breakbulk/Container
Transporter, 34 Ton M872/M872A1/M872A2/M872A3 TM 9-2330-358-14&P
- Operator's, Unit, Direct Support, and General Support
Maintenance Manual (Including Repair Parts and Special
Tools List) for Semitrailer, Tactical, Dual Purpose
Breakbulk/Container Transporter, 22 ½ Ton
M871/M871A1 TM 9-2330-359-14&P
- Operator's, Unit, Direct Support, and General Support
Maintenance Manual (Including Repair Parts and Special
Tools List) for Semitrailer, Tank, Fuel, 7500 Gallon,
M1062 TM 9-2330-384-14&P
- Operator's, Unit, Direct Support, and General Support
Maintenance Manual (Including Repair Parts and Special
Tools List) for Semitrailer, Tank, Fuel, 5000 Gallon,
M967/M969 TM 9-2330-356-14&P
- Principles of Automotive Vehicles TM 9-8000
- Procedures for Destruction of Tank-automotive Equipment to
Prevent Enemy Use TM 750-244-6
- Rigging TM 5-725

TECHNICAL BULLETINS

- CARC Spot Painting TB 43-0242
- Rust Proofing Procedures for Truck, Utility TB 43-0213
- Warranty Bulletin for M915A4. TB 9-2320-303-15

OTHER PUBLICATIONS

- Abbreviations and Acronyms ASME Y14.38-1999
- Army Acquisition Policy AR 70-1
- Army Medical Department Expendable/Durable Items CTA 8-100
- Expendable/Durable Items (Except Medical, Class V,
Repair Parts, and Heraldic Items) CTA 50-970
- Prevention of Motor Vehicle Accidents AR 385-55

END OF WORK PACKAGE

**COMPONENTS OF END ITEM (COEI)
AND BASIC ISSUE ITEMS (BII) LISTS**

0019 00

SCOPE

This work package lists Components of End Item and Basic Issue Items for the M915A4 truck tractor to help you inventory items required for safe and efficient operation.

GENERAL

The Components of End Item (COEI) and Basic Issue Items (BII) information are divided into the following lists:

- a. **Components of End Item.** This listing is for informational purposes only and is not authority to requisition replacements. These items are part of the end item, but are removed and separately packaged for transportation or shipment. As part of the end item, these items must be with the end item whenever it is issued or transferred between property accounts. Illustrations are furnished to assist you in identifying the items.
- b. **Basic Issue Items.** These are the minimum essential items required to place the truck in operation, to operate it, and to perform emergency repairs. Although shipped separately packaged, BII must be with the truck during operation and whenever it is transferred between property accounts. The illustrations will assist you with hard-to-identify items. This manual is your authority to request/requisition replacement BII, based on TOE/MTOE authorization of end item.

EXPLANATION OF COLUMNS

Below is an explanation of columns found in the tabular listings:

- a. **Column (1) - Illustration Number (Illus Number).** This column indicates the number of the illustration that shows the item.
- b. **Column (2) - National Stock Number.** Indicates the National Stock Number (NSN) assigned to the item to be used for requisitioning purposes.
- c. **Column (3) - Description, CAGEC, and Part Number.** Indicates the Federal item name (in all capital letters) followed by a minimum description when needed. The stowage location of COEI and BII is also included in this column. The last line below the description is the CAGEC (Commercial and Government Entity Code) (in parentheses) and the part number.
- d. **Column (4) - Usable on Code.** When applicable, gives you a code if the item you need is not the same for different models of equipment.
- e. **Column (5) - Unit of Issue (U/I).** Indicates how the item is issued for the National Stock Number show in Column (2).
- f. **Column (6) - Quantity Required (Qty/Rqd).** Indicates the quantity of the item authorized to be used with the equipment.

**COMPONENTS OF END ITEM (COEI)
AND BASIC ISSUE ITEMS (BII) LISTS - CONTINUED**

0019 00

COMPONENTS OF END ITEM

There are currently no COEI assigned.

**COMPONENTS OF END ITEM AND
BASIC ISSUE ITEMS LISTS - CONTINUED**

0019 00

BASIC ISSUE ITEMS

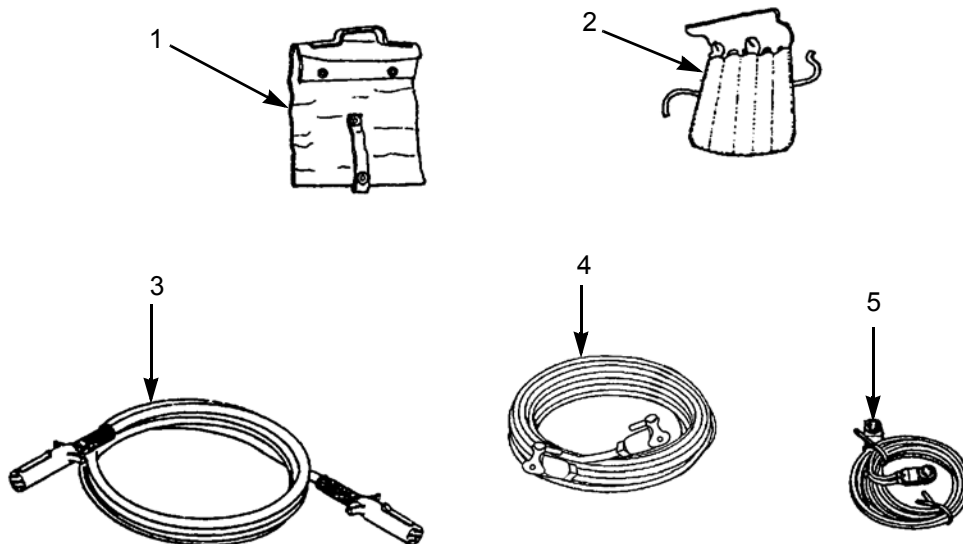

402-072

(1) Illus Number	(2) National Stock Number	(3) Description (CAGEC) Part Number	(4) Usable on Code	(5) U/I	(6) Qty Rqd
1	2540-00-670-2459	Bag, Pamphlet (in cab glove box) (19207) 11676920		EA	1
2	5140-00-356-8471	Bag, Tool (in BII storage box) (19204) 7541507		EA	1
3	6150-01-478-6510	Cable Assy, Power 12 volt, Tractor-Tri, 12 ft. (in BII storage box) (64678) PHM-42FL40-144		EA	1
4	6150-00-772-8814	Cable Assy, 12 ft., 24 volt (in BII storage box) (19207) 7728814		EA	1
5	6150-01-022-6004	Cable, Power NATO (in BII storage box) (19207) 11682336-1		EA	1

**COMPONENTS OF END ITEM AND
BASIC ISSUE ITEMS LISTS - CONTINUED**

0019 00

BASIC ISSUE ITEMS - CONTINUED

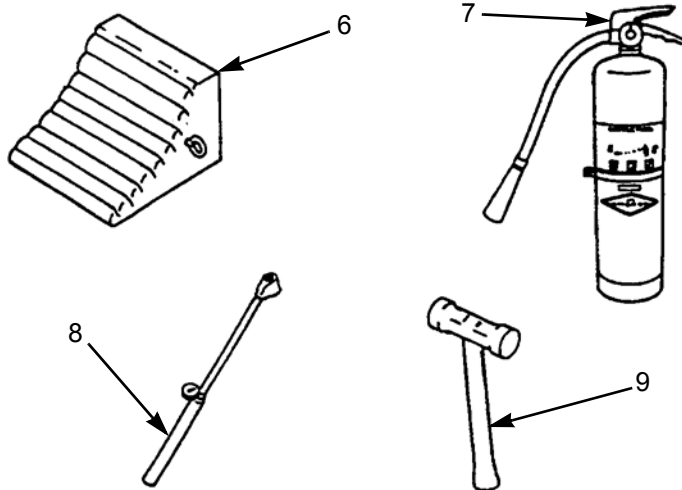

402-073

(1) Illus Number	(2) National Stock Number	(3) Description (CAGEC) Part Number	(4) Usable on Code	(5) U/I	(6) Qty Rqd
6	2540-00-678-3469	Chock, Wheel (in BII storage box) (58536) A-A-52475-1		EA	2
7	4210-01-338-6064	Extinguisher, Fire (on cab floor) (54905) 447		EA	1
8	4910-01-003-9599	Gage, Tire (in tool bag) (19207) 7974576-1		EA	1
9	5120-00-242-3915	Hammer (in BII storage box) (80063) SMC133095		EA	1

**COMPONENTS OF END ITEM AND
BASIC ISSUE ITEMS LISTS - CONTINUED**

0019 00

BASIC ISSUE ITEMS - CONTINUED

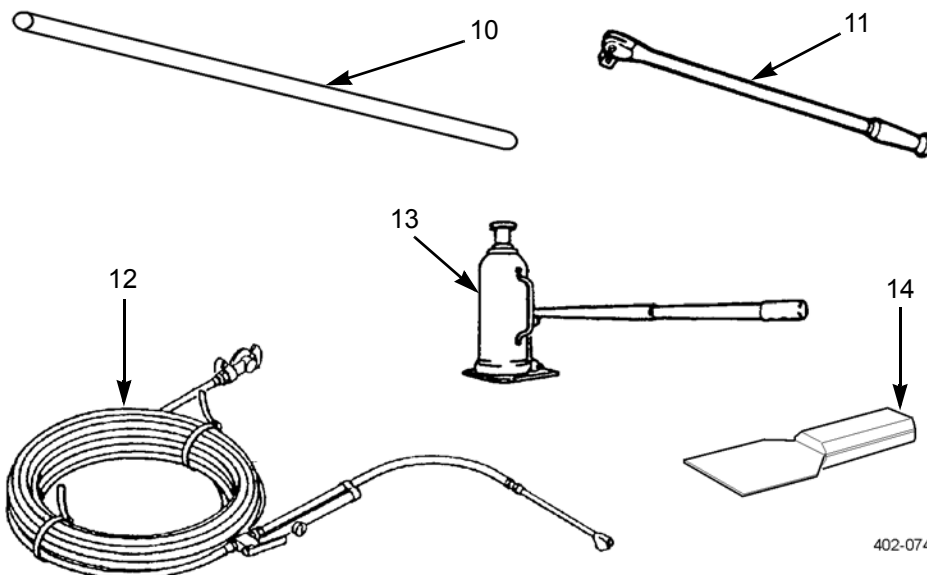

(1) Illus Number	(2) National Stock Number	(3) Description (CAGEC) Part Number	(4) Usable on Code	(5) U/I	(6) Qty Rqd
10	5120-00-243-2419	Handle, Lug Wrench (in BII storage box) (19207) 6196147		EA	1
11	5120-00-221-7958	Handle, Wrench (in BII storage box) (19207) 6169933			
12	4910-01-407-2953	Hose, Pneumatic, (Tire Infla- tion) with Gauge, 40 ft. (in BII storage box) (19207) 11677140-7		EA	1
13	5120-01-146-8096	Jack Hydraulic, 12 Ton w/2- piece Handle (in BII storage box) (63704) 28961		EA	1
14	5110-00-223-8827	Knife, Scraping: 3 inch blade (in tool bag) (80204) PD 5110-00-223-8827		EA	1

**COMPONENTS OF END ITEM AND
BASIC ISSUE ITEMS LISTS - CONTINUED**

0019 00

BASIC ISSUE ITEMS - CONTINUED

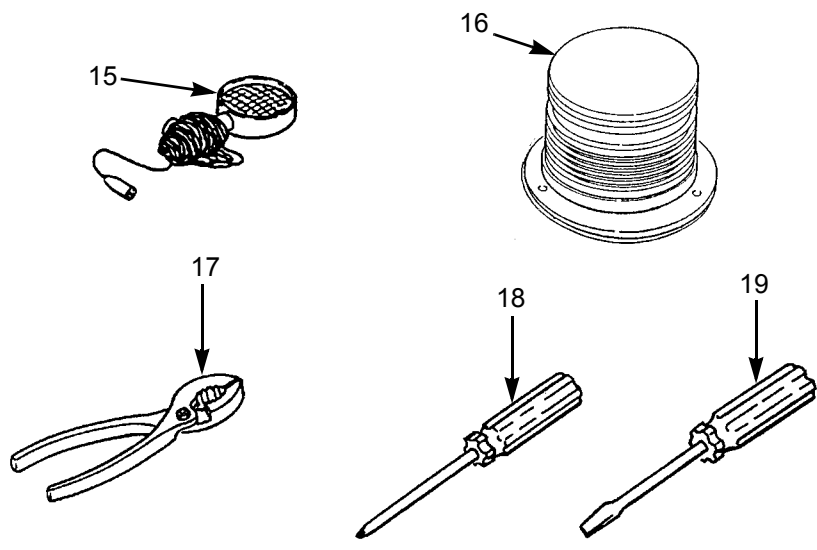

402-075

(1) Illus Number	(2) National Stock Number	(3) Description (CAGEC) Part Number	(4) Usable on Code	(5) U/I	(6) Qty Rqd
15	6220-01-327-3225	Lamp, Work, Vehicular 12 volt, 25 ft. Cord (in BII storage box) (78422) 1401152		EA	2
16	6220-01-495-2851	Light, Warning (66654) SY22011H-A		EA	1
17	5120-01-398-7966	Pliers, Slipjoint (in BII storage box) (96508) J26		EA	1
18	5120-00-234-8913	Screwdriver, Crosstip (in BII storage box) (19207) 11655777-12		EA	1
19	5120-00-227-7356	Screwdriver, Flat Tip (in BII storage box) (64067) 5120-00-227-7356		EA	1

**COMPONENTS OF END ITEM AND
BASIC ISSUE ITEMS LISTS - CONTINUED**

0019 00

BASIC ISSUE ITEMS - CONTINUED

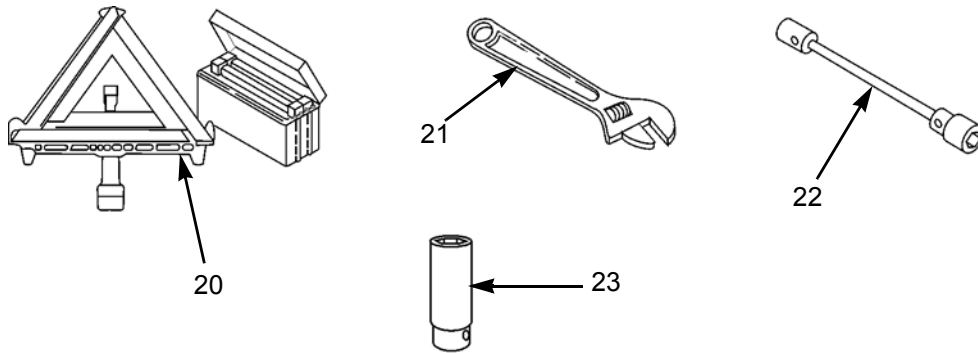

402-076

(1) Illus Number	(2) National Stock Number	(3) Description (CAGEC) Part Number	(4) Usable on Code	(5) U/I	(6) Qty Rqd
20	9905-00-148-9546	Warning Device Kit (in BII storage box) (19207) 11669000		EA	1
21	5120-00-240-5328	Wrench, Adjustable, 8 in. (in BII storage box) (19207) 11655778-3		EA	1
22	5120-00-293-1289	Wrench, Socket (in BII storage box) (19207) 41-W-3838-30		EA	1
23	5130-00-714-0600	Wrench, Socket, 15/16 (in BII storage box) (1CV05) 7330H		EA	1

END OF WORK PACKAGE

ADDITIONAL AUTHORIZATION LIST (AAL)

0020 00**SCOPE**

This work package lists additional items that you are authorized for the support of the M915A4 truck tractor.

GENERAL

This list identifies items that do not have to accompany the truck and that do not have to be turned in with it. These items are authorized to you by CTA, MTOE TDA, or JTA.

EXPLANATION OF COLUMNS IN THE AAL

1. **Column (1) - National Stock Number (NSN)**. Identifies the stock number of the item to be used for requisitioning purposes.
2. **Column (2) - Description, Commercial and Government Entity Code (CAGEC), and Part Number (P/N)**. Identifies the Federal item name (in all capital letters) followed by a minimum description when needed. The last line below the description is the CAGEC (in parentheses) and the part number.
3. **Column (3) - Usable on Code**. When applicable, gives you a code if the item you need is not the same for different models of equipment.
4. **Column (4) - Unit of Measure (U/M)**. Indicates the physical measurement or count of the item as issued per the National Stock Number shown in Column (1).
5. **Column (5) - Qty Recm**. Indicates the quantity recommended.

ADDITIONAL AUTHORIZATION LIST - CONTINUED

0020 00

Table 1. Additional Authorization List.

(1) National Stock Number	(2) Description, CAGEC, and Part Number	(3) Usable on Code	(4) U/M	(5) Qty Recm
6130-01-449-7594	ANALYZER, CHARGER: Battery (09GZS) VC-5		ea	1
5110-00-293-2336	AXE, SINGLE BIT: 4-16-HD Wt, 35.5- 36.5 in. Long (19207) 6150925		ea	1
7510-00-889-3494	BINDER, LOOSELEAF (19207) 11677003		ea	1
5510-00-491-0306	BLOCK, WOOD: 4X8X9 in. (19207) CPR103023-1		ea	1
5510-00-491-0307	BLOCK, WOOD: 7X8X9 in. (19207) CPR103023-2		ea	1
5340-01-345-4676	BRACKET, MOUNTING: Decontamination Kit (64678) 681 899 01 K0		ea	1
2540-01-453-0497	CHAINS, TIRE (80535) 2245		pr	2
5340-00-545-2337	CLEVIS, ROD END Part of Tow Bar 2540-01-267-2912 (19207) 8724449		ea	2
4230-01-133-4124	DECONTAMINATION APPARATUS (81361) E5-51-527		ea	1
5120-00-288-6574	HANDLE, MATTOCK-PICK: 35.5-36.5 in. Long (19207) 11677021		ea	1
5895-01-361-7606	INSTALLATION KIT, SINCGARS (80063) A3104086		ea	1
2530-01-479-4198	KIT, AIR DEFLECTOR (64678) 681 790 02 K0		ea	1

ADDITIONAL AUTHORIZATION LIST - CONTINUED

0020 00

Table 1. Additional Authorization List - Continued.

(1) National Stock Number	(2) Description, CAGEC, and Part Number	(3) Usable on Code	(4) U/M	(5) Qty Recm
2540-01-479-2467	KIT, ARCTIC HEATER (64678) 681 830 10 K2		ea	1
6545-00-922-1200	KIT, FENDER (64678) A22-53823-000		ea	1
1005-01-439-9229	KIT, FIRST AID (19207) 11677011		ea	1
5120-00-243-2395	KIT, RIFLE MOUNTING (64678) 681 816 00 K2		ea	1
5340-00-158-3805	MATTOCK: 5 Lb Without Handle (19207) 11677022		ea	1
5315-00-539-9174	PADLOCK (58536) AA59487-2S		ea	4
5315-00-350-4326	PIN Part of Tow Bar 2540-01-267-2912 (19207) 10929861		ea	1
5120-00-293-3336	PIN, LOCKING Part of Tow Bar 2540-01-267-2912 (19207) 5213744		ea	1
2610-01-506-0388	SHOVEL, HAND: Rd-Pt, D-Hdl, Short Size 2 (19207) 11655784		ea	1
2540-01-267-2912	TIRES, OFF-ROAD: XZY-2, 11R22.5, H (12195) 97624		ea	1
2540-01-267-2912	TOW BAR: Medium Duty (19207) 12322663		ea	1

END OF WORK PACKAGE

EXPENDABLE AND DURABLE ITEMS LIST

0021 00

SCOPE

This work package lists expendable and durable items you will need to operate and maintain the M915A4. This listing is for informational purposes only and is not authority to requisition the listed items. These items are authorized to you by CTA 50-970, *Expendable/Durable Items (Except Medical, Class V, Repair Parts, and Heraldic Items)*, or CTA 8-100, *Army Medical Department Expendable/Durable Items*.

EXPLANATION OF COLUMNS IN THE EXPENDABLE/DURABLE ITEMS LIST

- a. **Column (1) - Item Number.** This number is assigned to the entry in the listing and is referenced in the narrative instructions to identify the item [e.g., Use detergent (Item 5, WP 0021 00)].
- b. **Column (2) - Level.** This column identifies the lowest level of maintenance that requires the listed item.

C - Operator/Crew
- c. **Column (3) - National Stock Number.** This is the National Stock Number assigned to the item which you can use to requisition it.
- d. **Column (4) - Item Name, Description, Commercial and Government Entity Code (CAGEC), and Part Number.** This provides the other information you need to identify the item.
- e. **Column (5) - Unit of Measure (U/M)/Unit of Issue (U/I).** This column shows the physical measurement or count of an item, such as gallon, dozen, gross, etc.

EXPENDABLE AND DURABLE ITEMS LIST - CONTINUED

0021 00

Table 1. Expendable and Durable Items List.

(1) Item Number	(2) Level	(3) National Stock Number	(4) Item Name, Description CAGEC, and Part Number	(5) U/M
1	C	6850-01-441-3218 6850-00-181-7933 6850-01-441-3223	ANTIFREEZE: Permanent, Ethylene Glycol, Inhibited (58536) AA52624-1-A 1 Gallon Bottle 5 Gallon Can 55 Gallon Drum	gl gl gl
2	C	6850-01-441-3248	ANTIFREEZE: Permanent, Type: Arctic Grade (58536) A-A-52624 55 Gallon Drum	gl
3	C	6850-00-926-2275	COMPOUND: Cleaning, Windshield (0FTT5) 0854-000 16 Ounce Can	oz
4	C	7930-00-282-9699	DETERGENT: General Purpose, Liquid (83421) 7930-00-282-9699 1 Gallon Can	gl
5	C	9140-00-286-5295 9140-00-286-5296 9140-00-286-5297	FUEL: Diesel, DF-2 Grade (81346) ASTM D 975 5 Gallon Can DF-1 Grade 55 Gallon Drum, 16 Gage 55 Gallon Drum, 18 Gage	gl gl gl
6	C	9130-01-031-5816	FUEL, TURBINE: Aviation (81349) MILT83133 GR JP8	gl

EXPENDABLE AND DURABLE ITEMS LIST - CONTINUED

0021 00

Table 1. Expendable and Durable Items List - Continued.

(1) Item Number	(2) Level	(3) National Stock Number	(4) Item Name, Description CAGEC, and Part Number	(5) U/M
7	C		GREASE: Automotive and Artillery, GAA (81349) M-10924-A	
		9150-01-197-7693	14 Ounce Cartridge	oz
		9150-01-197-7688	2 1/4 Ounce Tube	oz
		9150-01-197-7690	2 1/4 Pound Can	lb
		9150-01-197-7692	35 Pound Pail	lb
		9150-01-197-7691	120 Pound Drum	lb
8	C		OIL: Lubricating GO 75 (81349) M2105-1-75W	
		9150-01-035-5390	1 Quart Can	qt
		9150-01-035-5391	5 Gallon Can	gl
9	C		OIL: Lubricating, Gear, Multipurpose, GO 80/90 (81349) M2105-1-80W90	
		9150-01-035-5392	1 Quart Can	qt
		9150-01-035-5395	5 Gallon Can	gl
		9150-01-035-5394	55 Gallon Drum, 16 Gage	gl
10	C		OIL: Lubricating GO: 85/140 (81349) M2105-1-85W140	
		9150-01-048-4591	1 Quart Can	qt
		9150-01-035-5395	5 Gallon Can	gl
		9150-01-035-5396	55 Gallon Drum	gl
11	C		OIL: Lubricating, Internal Combustion Engine, Arctic, OEA (81349) MIL-PRF-46167	
		9150-00-402-4478	1 Quart Can	qt
		9150-00-402-2372	5 Gallon Drum	gl
		9150-00-491-7197	55 Gallon Drum	gl

EXPENDABLE AND DURABLE ITEMS LIST - CONTINUED

0021 00

Table 1. Expendable and Durable Item List - Continued.

(1) Item Number	(2) Level	(3) National Stock Number	(4) Item Name, Description CAGEC, and Part Number	(5) U/M
12	C		OIL: Lubricating, Internal Combustion Engine, OE/HDO 10 (81349) M2104-1-10W	
		9150-00-189-6727	1 Quart Can	qt
		9150-00-186-6668 9150-00-191-2772	5 Gallon Can 55 Gallon Drum	gl gl
13	C		OIL: Lubricating, Engine, OE/HDO 15W/40 (81349) M2104-5-15W40	
		9150-01-152-4117	1 Quart Can	qt
		9150-01-152-4118 9150-01-152-4119	5 Gallon Can 55 Gallon Drum	gl gl
14	C		OIL: Lubricating, Internal Combustion Engine, OE/HDO 30 (81349) M2104-1-30W	
		9150-00-186-6681	1 Quart Can	qt
		9150-00-188-9858 9150-00-189-6729	5 Gallon Can 55 Gallon Drum	gl gl
15	C		OIL: Lubricating, Internal Combustion Engine, OE/HDO 40 (81349) MIL-PRF-2104	
		9150-00-189-6730	1 Quart Can	qt
		9150-00-188-9862	55 Gallon Drum	gl
16	C		RAG: Wiping (64067) 7920-00-205-1711	
		7920-00-205-1711	50 Pound Bale	lb
17	C		TAPE: Reflective, 2 Inches Wide (81346) ASTM D4956	
		9390-00-174-2322	1800 Inch Roll	in

END OF WORK PACKAGE

INDEX

<i>Subject</i>	<i>Work Package/ Page Number</i>
A	
Abbreviations, List of	0001 00-2
Additional Authorization List (AAL)	0020 00-1
Additional Controls and Indicators	0004 00-21
Air Conditioner, Operate	0005 00-20
Air Conditioning System, Theory of Operation	0003 00-9
Air System, Theory of Operation	0003 00-5
B	
Basic Issue Items (BII) List	0019 00-1
Battery Box Cover Replacement	0015 00-1
Brake System, Theory of Operation	0003 00-6
C	
Cab Floor-Mounted Controls	0004 00-13
Cage and Uncage Brakes	0006 00-3
Cleaning and Refueling Instructions, Truck	0013 00-1
Collision Warning System (CWS)	0004 00-17
Collision Warning System (CWS), Power Up	0005 00-5
Collision Warning System (CWS), Theory of Operation	0003 00-10
Components of End Item (COEI) List	0019 00-1
Controls and Indicators, Operator's, Description and Use of	0004 00-1
Controls:	
Cab Floor-Mounted	0004 00-13
Cooling System, Theory of Operation	0003 00-3
Corrosion Prevention and Control (CPC)	0001 00-1
D	
Decals and Plates	0007 00-1
Description and Use of Operator's Controls and Indicators	0004 00-1
Destruction of Army Materiel to Prevent Enemy Use	0001 00-2
Drive Train	0003 00-1

INDEX - Continued

<i>Subject</i>	<i>Work Package/ Page Number</i>
----------------	--------------------------------------

D - Continued

Driving	0005 00-10
Driving Tips	0005 00-7

E

Electrical System, Theory of Operation	0003 00-4
Equipment Characteristics, Capabilities, and Features	0002 00-1
Equipment Data	0002 00-6
Equipment Description and Data	0002 00-1
Equipment Improvement Recommendations (EIRs), Reporting	0001 00-1
Exhaust System, Theory of Operation	0003 00-3
Expendable and Durable Items List	0021 00-1
Extreme Cold, Operate in	0006 00-5
Extreme Heat, Operate in	0006 00-8

F

Field Manuals	0018 00-1
Fording	0006 00-9
Forms	0018 00-1
Fuel System, Theory of Operation	0003 00-2

G

General Information	0001 00-1
---------------------------	-----------

H

Heater and Defroster, Operate	0005 00-20
-------------------------------------	------------

I

Initial Adjustments, Before Use, and Self-Tests	0005 00-1
Instrument Panel	0004 00-2

INDEX - Continued

<i>Subject</i>	<i>Work Package/ Page Number</i>
L	
Lights, Operate	0005 00-22
List of Abbreviations	0001 00-2
Location and Description of Major Components	0002 00-2
Lubrication Instructions	0017 00-1
M	
Maintenance Forms and Procedures	0001 00-1
Major Components, Location and Description of	0002 00-2
Mud Flap Stowage	0005 00-19
Mud or Soft Surfaces, Operate in	0006 00-8
N	
Nomenclature Cross-Reference List	0001 00-2
O	
Operate Tilttable Hood	0005 00-26
Operation Under Unusual Conditions	0006 00-1
Operation Under Usual Conditions	0005 00-1
Operator's Controls and Indicators, Description and Use of	0004 00-1
Other Publications	0018 00-2
Ozone Depleting Substances (ODS)	0001 00-2
P	
Pintle Towing Procedures	0005 00-18
Portable Fire Extinguisher, Operate	0005 00-21
Preparation for Storage or Shipment	0001 00-2
Preparation for Transport	0005 00-25
Preventative Maintenance Checks and Services (PMCS) Introduction	0011 00-1
Preventive Maintenance Checks and Services (PMCS)	0012 00-1
Publication Indexes	0018 00-1

INDEX - Continued

<i>Subject</i>	<i>Work Package/ Page Number</i>
R	
Rear Window Guard Replacement	0016 00-1
References	0018 00-1
Reporting Equipment Improvement Recommendations (EIRs)	0001 00-1
Rifle Mounting Kit	0005 00-24
S	
Sandy or Dusty Conditions, Operate in	0006 00-9
Seat Controls	0004 00-15
Shut Down Engine	0005 00-11
Slave Start Truck	0006 00-1
Sliding Fifth Wheel/Couple to Semitrailer, Operate	0005 00-12
Sliding Fifth Wheel/Uncouple from Semitrailer, Operate	0005 00-16
Snow or Ice, Operate on	0006 00-11
Spare Wheel and Tire Assembly Carrier, Operation of	0014 00-3
Start Engine	0005 00-3
Steering System, Theory of Operation	0003 00-8
Steering Wheel and Column-Mounted Controls	0004 00-12
Storage or Shipment, Preparation for	0001 00-2
Stowage and Decal, Data Plate, and Stencil Guide	0007 00-1
Stowage and Stencils	0007 00-4
Suspension System, Theory of Operation	0003 00-12
T	
Technical Bulletins	0018 00-2
Technical Manuals	0018 00-2
Theory of Operation	0003 00-1
Tow Truck	0006 00-2
Traction Control System, Theory of Operation	0003 00-11
Transmission, Operate	0005 00-6

INDEX - Continued

Subject *Work Package/
Page Number*

T - Continued

Troubleshooting	
Procedures	0010 00-1
Symptom Index	0009 00-1
Troubleshooting Instructions	0008 00-1
Truck Cleaning and Refueling Instructions	0013 00-1

W

Warranty Information	0001 00-2
Wheel and Tire Assembly Replacement	0014 00-4
Wheel and Tire Maintenance Instructions	0014 00-1
Woods or on Rocky Terrain, Operate in	0006 00-10

By Order of the Secretary of the Army:

PETER J. SCHOOMAKER
General, United States Army
Chief of Staff

Official:

SANDRA R. RILEY
Administrative Assistant to the
Secretary of the Army
0508904

DISTRIBUTION: To be distributed in accordance with the initial distribution number (IDN) 381111, requirements for TM 9-2320-303-10.

RECOMMENDED CHANGES TO PUBLICATIONS AND BLANK FORMS <small>For use of this form, see AR 25-30; the proponent agency is ODISC4.</small>						Use Part II (reverse) for Repair Parts and Special Tool Lists (RPSTL) and Supply Catalogs/Supply Manuals (SC/SM).	DATE 1 July 2005
TO: (Forward to proponent of publication or form) (Include ZIP Code) AMSTA-LC-LMIT/TECH PUBS, TACOM-RI 1 Rock Island Arsenal Rock Island, IL 61299-7630						FROM: (Activity and location) (Include ZIP Code) 125th Transportation Company ATTN: Motor SGT (SGT Wilson) Ft. Riley, KA 78665-4000	
PART I - ALL PUBLICATIONS (EXCEPT RPSTL AND SC/SM) AND BLANK FORMS							
PUBLICATION/FORM NUMBER TM 9-2320-303-10						DATE 31 December 2005	TITLE Truck, Tractor, Line Haul, Operator's Manual
ITEM	PAGE	PARA-	LINE	FIGURE NO.	TABLE	RECOMMENDED CHANGES AND REASON	
	0020 00-2					Part number for item 5, detergent, is incorrect	
SAMPLE							
<small>* Reference to line numbers within the paragraph or subparagraph.</small>							
TYPED NAME, GRADE OR TITLE Johnny Wilson, E-5, MOTOR SGT						TELEPHONE EXCHANGE/AUTOVON, PLUS EXTENSION DSN 867-7967	SIGNATURE

TO: (Forward direct to addressee listed in publication)			FROM: (Activity and location) (Include ZIP Code)				DATE	
PART II - REPAIR PARTS AND SPECIAL TOOL LISTS AND SUPPLY CATALOGS/SUPPLY MANUALS								
PUBLICATION NUMBER				DATE		TITLE		
PAGE NO.	COLM NO.	LINE NO.	NATIONAL STOCK NUMBER	REFERENCE NO.	FIGURE NO.	ITEM NO.	TOTAL NO. OF MAJOR ITEMS SUPPORTED	RECOMMENDED ACTION
<h1>SAMPLE</h1>								
REMARKS: (General comments, recommendations, etc.)								
TYPED NAME, GRADE OR TITLE			TELEPHONE EXCHANGE/AUTOVON, PLUS EXTENSION			SIGNATURE		

RECOMMENDED CHANGES TO PUBLICATIONS AND BLANK FORMS <small>For use of this form, see AR 25-30; the proponent agency is OAASA</small>						Use Part II (<i>reverse</i>) for Repair Parts and Special Tool Lists (RPSTL) and Supply Catalogs/Supply Manuals (SC/SM).	DATE
TO: (<i>Forward to proponent of publication or form</i>) (<i>Include ZIP Code</i>) AMSTA-LC-LMIT/TECH PUBS, TACOM-RI 1 Rock Island Arsenal Rock Island, IL 61299-7630						FROM: (<i>Activity and location</i>) (<i>Include ZIP Code</i>)	
PART I - ALL PUBLICATIONS (EXCEPT RPSTL AND SC/SM) AND BLANK FORMS							
PUBLICATION/FORM NUMBER TM 9-2320-303-10					DATE 31 December 2005	TITLE Truck, Tractor, Line Haul, Operator's Manual	
ITEM	PAGE	PARA-	LINE	FIGURE NO.	TABLE	RECOMMENDED CHANGES AND REASON	
TYPED NAME, GRADE OR TITLE					TELEPHONE EXCHANGE/AUTOVON, PLUS EXTENSION		SIGNATURE

TO: <i>(Forward direct to addressee listed in publication)</i>			FROM: <i>(Activity and location) (Include ZIP Code)</i>				DATE	
PART II - REPAIR PARTS AND SPECIAL TOOL LISTS AND SUPPLY CATALOGS/SUPPLY MANUALS								
PUBLICATION NUMBER				DATE		TITLE		
PAGE NO.	COLM NO.	LINE NO.	NATIONAL STOCK NUMBER	REFERENCE NO.	FIGURE NO.	ITEM NO.	TOTAL NO. OF MAJOR ITEMS SUPPORTED	RECOMMENDED ACTION
PART III - REMARKS <i>(Any general remarks or recommendations, or suggestions for improvement of publications and blank forms. Additional blank sheets may be used if more space is needed.)</i>								
TYPED NAME, GRADE OR TITLE				TELEPHONE EXCHANGE/AUTOVON, PLUS EXTENSION			SIGNATURE	

RECOMMENDED CHANGES TO PUBLICATIONS AND BLANK FORMS <small>For use of this form, see AR 25-30; the proponent agency is OAASA</small>						Use Part II (<i>reverse</i>) for Repair Parts and Special Tool Lists (RPSTL) and Supply Catalogs/Supply Manuals (SC/SM).	DATE
TO: (<i>Forward to proponent of publication or form</i>) (<i>Include ZIP Code</i>) AMSTA-LC-LMIT/TECH PUBS, TACOM-RI 1 Rock Island Arsenal Rock Island, IL 61299-7630						FROM: (<i>Activity and location</i>) (<i>Include ZIP Code</i>)	
PART I - ALL PUBLICATIONS (EXCEPT RPSTL AND SC/SM) AND BLANK FORMS							
PUBLICATION/FORM NUMBER TM 9-2320-303-10					DATE 31 December 2005	TITLE Truck, Tractor, Line Haul, Operator's Manual	
ITEM	PAGE	PARA-	LINE	FIGURE NO.	TABLE	RECOMMENDED CHANGES AND REASON	
TYPED NAME, GRADE OR TITLE					TELEPHONE EXCHANGE/AUTOVON, PLUS EXTENSION		SIGNATURE

TO: <i>(Forward direct to addressee listed in publication)</i>			FROM: <i>(Activity and location) (Include ZIP Code)</i>				DATE	
PART II - REPAIR PARTS AND SPECIAL TOOL LISTS AND SUPPLY CATALOGS/SUPPLY MANUALS								
PUBLICATION NUMBER				DATE		TITLE		
PAGE NO.	COLM NO.	LINE NO.	NATIONAL STOCK NUMBER	REFERENCE NO.	FIGURE NO.	ITEM NO.	TOTAL NO. OF MAJOR ITEMS SUPPORTED	RECOMMENDED ACTION
PART III - REMARKS <i>(Any general remarks or recommendations, or suggestions for improvement of publications and blank forms. Additional blank sheets may be used if more space is needed.)</i>								
TYPED NAME, GRADE OR TITLE				TELEPHONE EXCHANGE/AUTOVON, PLUS EXTENSION			SIGNATURE	

RECOMMENDED CHANGES TO PUBLICATIONS AND BLANK FORMS						Use Part II (<i>reverse</i>) for Repair Parts and Special Tool Lists (RPSTL) and Supply Catalogs/Supply Manuals (SC/SM).	DATE
<small>For use of this form, see AR 25-30; the proponent agency is OAASA</small>							
TO: (<i>Forward to proponent of publication or form</i>) (<i>Include ZIP Code</i>)				FROM: (<i>Activity and location</i>) (<i>Include ZIP Code</i>)			
AMSTA-LC-LMIT/TECH PUBS, TACOM-RI 1 Rock Island Arsenal Rock Island, IL 61299-7630							
PART I - ALL PUBLICATIONS (EXCEPT RPSTL AND SC/SM) AND BLANK FORMS							
PUBLICATION/FORM NUMBER					DATE	TITLE	
TM 9-2320-303-10					31December 2005	Truck, Tractor, Line Haul, Operator's Manual	
ITEM	PAGE	PARA-	LINE	FIGURE NO.	TABLE	RECOMMENDED CHANGES AND REASON	
TYPED NAME, GRADE OR TITLE					TELEPHONE EXCHANGE/AUTOVON, PLUS EXTENSION		SIGNATURE

TO: <i>(Forward direct to addressee listed in publication)</i>			FROM: <i>(Activity and location) (Include ZIP Code)</i>				DATE	
PART II - REPAIR PARTS AND SPECIAL TOOL LISTS AND SUPPLY CATALOGS/SUPPLY MANUALS								
PUBLICATION NUMBER				DATE		TITLE		
PAGE NO.	COLM NO.	LINE NO.	NATIONAL STOCK NUMBER	REFERENCE NO.	FIGURE NO.	ITEM NO.	TOTAL NO. OF MAJOR ITEMS SUPPORTED	RECOMMENDED ACTION
PART III - REMARKS <i>(Any general remarks or recommendations, or suggestions for improvement of publications and blank forms. Additional blank sheets may be used if more space is needed.)</i>								
TYPED NAME, GRADE OR TITLE				TELEPHONE EXCHANGE/AUTOVON, PLUS EXTENSION			SIGNATURE	

THE METRIC SYSTEM AND EQUIVALENTS

<p>Linear Measure</p> <p>1 Centimeter = 10 Millimeters = 0.01 Meters = 0.3937 Inches 1 Meter = 100 Centimeters = 1000 Millimeters = 39.37 Inches 1 Kilometer = 1000 Meters = 0.621 Miles</p> <p>Weights</p> <p>1 Gram = 0.001 Kilograms = 1000 Milligrams = 0.035 Ounces 1 Kilogram = 1000 Grams = 2.2 Pounds 1 Metric Ton = 1000 Kilograms = 1 Megagram = 1.1 Short Tons</p> <p>Liquid Measure</p> <p>1 Milliliter = 0.001 Liters = 0.0338 Fluid Ounces 1 Liter = 1000 Milliliters = 33.82 Fluid Ounces</p>	<p>Square Measure</p> <p>1 Sq Centimeter = 100 Sq Millimeters = 0.155 Sq Inches 1 Sq Meter = 10,000 Sq Centimeters = 10.76 Sq Feet 1 Sq Kilometer = 1,000,000 Sq Meters = 0.0386 Sq Miles</p> <p>Cubic Measure</p> <p>1 Cu Centimeter = 1,000 Cu Millimeters = 0.06 Cu Inches 1 Cu Meter = 1,000,000 Cu Centimeters = 35.31 Cu Feet</p> <p>Temperature</p> <p>$5/9 (^{\circ}\text{F} - 32) = ^{\circ}\text{C}$ 212° Fahrenheit is equivalent to 100° Celsius 90° Fahrenheit is equivalent to 32.2° Celsius 32° Fahrenheit is equivalent to 0° Celsius $9/5 \text{ C}^{\circ} + 32 = \text{F}^{\circ}$</p>
--	---

APPROXIMATE CONVERSION FACTORS

To Change	To	Multiply By
Inches	Centimeters	2.540
Feet	Meters	0.305
Yards	Meters	0.914
Miles	Kilometers	1.609
Sq Inches	Sq Centimeters	6.451
Sq Feet	Sq Meters	0.093
Sq Yards	Sq Meters	0.836
Sq Miles	Sq Kilometers	2.590
Acres	Sq Hectometers	0.405
Cubic Feet	Cubic Meters	0.028
Cubic Yards	Cubic Meters	0.765
Fluid Ounces	Milliliters	29.573
Pints	Liters	0.473
Quarts	Liters	0.946
Gallons	Liters	3.785
Ounces	Grams	28.349
Pounds	Kilograms	0.454
Short Tons	Metric Tons	0.907
Pound-Feet	Newton-Meters	1.356
Pounds per Sq Inch	Kilopascals	6.895
Miles per Gallon	Kilometers per Liter	0.425
Miles per Hour	Kilometers per Hour	1.609

To Change	To	Multiply By
Centimeters	Inches	0.394
Meters	Feet	3.280
Meters	Yards	1.094
Kilometers	Miles	0.621
Sq Centimeters	Sq Inches	0.155
Sq Meters	Sq Feet	10.764
Sq Meters	Sq Yards	1.196
Sq Kilometers	Sq Miles	0.386
Sq Hectometers	Acres	2.471
Cubic Meters	Cubic Feet	35.315
Cubic Meters	Cubic Yards	1.308
Milliliters	Fluid Ounces	0.034
Liters	Pints	2.113
Liters	Quarts	1.057
Liters	Gallons	0.264
Grams	Ounces	0.035
Kilograms	Pounds	2.205
Metric Tons	Short Tons	1.102
Newton-Meters	Pound-Feet	0.738
Kilopascals	Pounds per Sq Inch	0.145
Kilometers per Liter	Miles per Gallon	2.354
Kilometers per Hour	Miles per Hour	0.621

PIN: 079294-000